

# Pumps in Power Plants: Life Cycle Approach Ensures Reliability

**DOUG FILKER**  
SULZER PUMPS

*In the United States, the California power crisis has raised public awareness for the need of building new power plants in a short time. Highly efficient natural-gas-fired combined cycle plants are quick to construct and require low capital investment. Sulzer Pumps is a worldwide market leader for dependable boiler feed water pumps and other auxiliary pumps essential for the operation of these systems.*

■ National and local deregulation are causing a business boom in the North American power industry. Presently, over 190 000 MW of new electrical generation is being developed in the region. More than 95% of current new construction is based on combustion turbine technology. Natural-gas-fired turbines coupled to electrical generators provide on-demand low capital cost power to the transmission grid. Innovations in fuel burning technology and tur-

bine component metallurgy have pushed the output and operating efficiencies of these machines to new levels.

## **BROAD PRODUCT PORTFOLIO**

Many plants are designed with waste heat recovery steam generators (HRSG) to develop secondary power via steam turbine electrical generators (Fig. 1■ and 2■). The heart of these highly efficient combined cycle systems is the boiler feed water pump. Being high-ener-

gy machines, they have to be reliable under extreme operating conditions. As the turbine heat output increases, so does the demand for larger capacity and higher pressure boiler feed water pumps. With its experience, broad product portfolio and local service capability, Sulzer provides the basis for dependable boiler feed water pump operation and power generation. Also stimulated by the robust activity in power generation is coal-fired technology. Still the

1■ *The combined cycle power plant Pegasus in the Netherlands is one example of more than 900 power plants equipped with Sulzer pumps.*

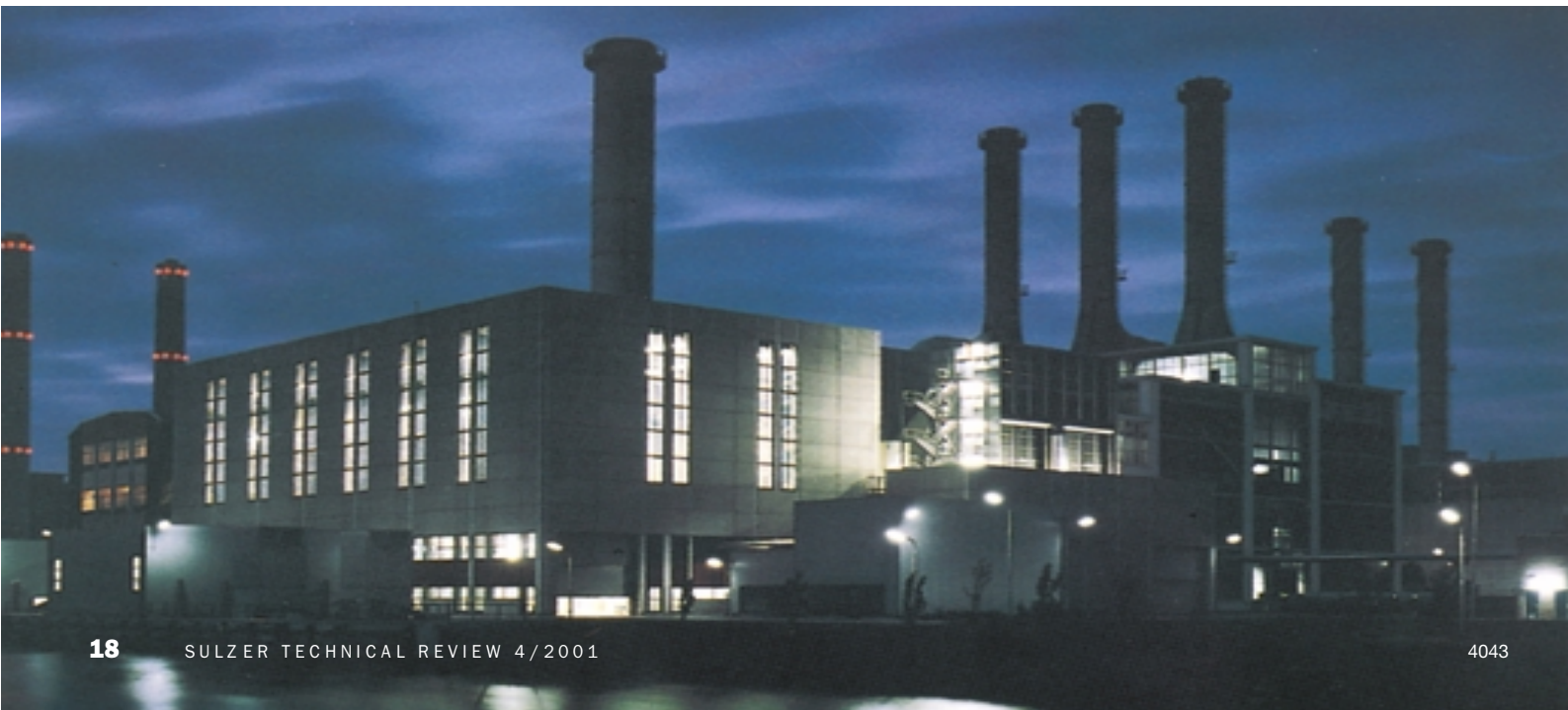

cheapest and most abundant fuel source available, coal competes with natural gas. In the future, combined with new electrical transmission concepts, efficient and low polluting coal-fired generating plants will be built right at the mine head. These plants typically use high-speed, high-energy, double-case boiler feed water pumps of the Sulzer HPT design.

### STANDARDIZED PLANT DESIGNS

Combined cycle power plants are designed using building block technology. A 1000-MW generating plant may have four modular 250-MW gas turbine blocks with individual or shared HRSGs. Major architect engineering and construction firms have their own standard plant designs. Based on the building block concept, power islands are built to meet today's and future demand for electrical energy. Siemens, Black & Veatch, Bechtel, Alstom Power, Lockwood Greene, Tractebel, Washington Group and Calpine are several companies who have standard modular plant designs. Sulzer's experience and product depth provides standard pump package solutions for them.

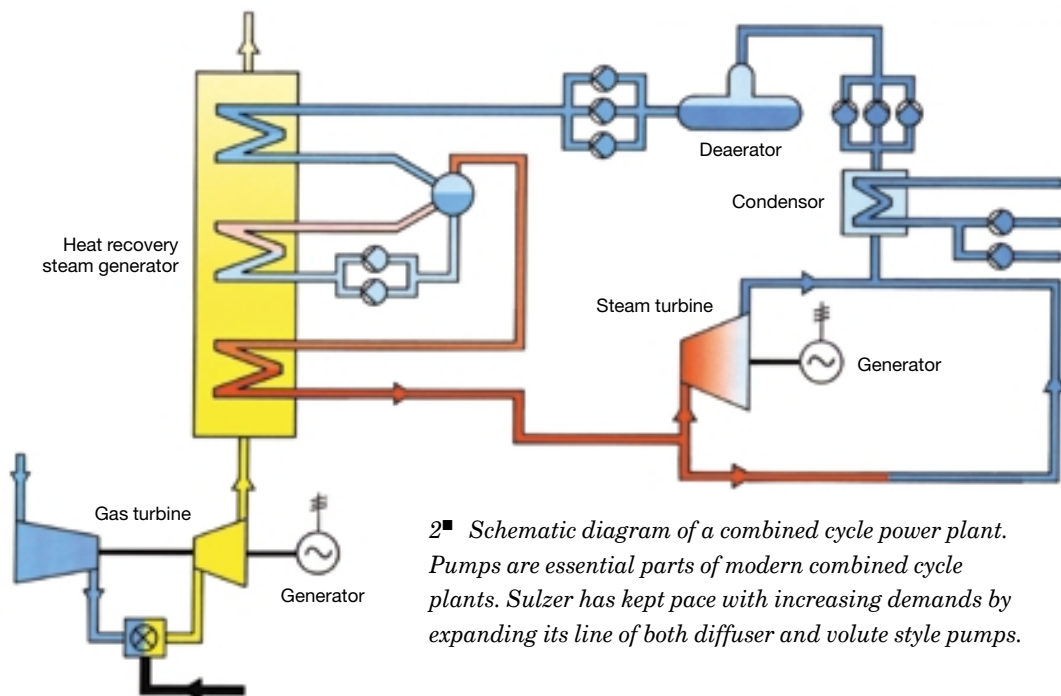

2<sup>■</sup> Schematic diagram of a combined cycle power plant. Pumps are essential parts of modern combined cycle plants. Sulzer has kept pace with increasing demands by expanding its line of both diffuser and volute style pumps.

### TESTS PRIOR TO INSTALLATION

These modular standardized plant designs no longer use redundant equipment. To meet the high demands on dependability, factory pump tests are conducted prior to shipping. Engineers simulate a variety of operating conditions such as hot transients, reduced suction pressure, full train operation or variable speeds. Vibration and noise levels are measured to discover any potential problems before they occur in the field. Full test capabilities are essential services available from Sulzer to prove performance and reliability. Sulzer has capability for these tests in North America, Europe, Brazil, India and South Africa (Fig. 3<sup>■</sup>).

At the site, proper installation is critical if pump reliability is to be achieved. Nozzle loading, alignment, instrumentation and control settings all must be brought to proper tolerance before commissioning. Additionally, operator knowledge and process control are necessary to maximize pump life

and availability, avoiding improper pump operation such as system upsets, loss of suction pressure, running at less than minimum flow, high bearing or oil temperature, excessive thermal transients



3<sup>■</sup> Providing for the North American market, Sulzer's test facility in Burnaby, British Columbia, Canada, is state of the art. The test rig is designed for high-energy pump testing in both 50- or 60-Hertz configurations.

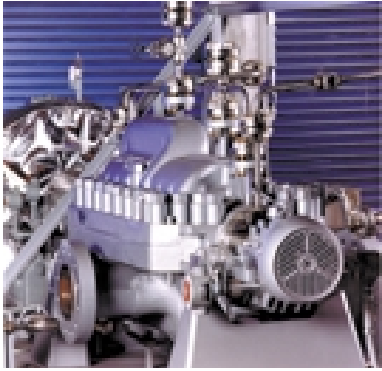

4<sup>■</sup> Boiler feed water pumps like this MSD are designed for extreme operating ranges. Typically installed without a backup, single 100% pump availability is largely dependent upon proper installation and operation of the equipment.

or improper starts and stops. Sulzer's full-service organization provides supervision assistance, operation training and maintenance services to ensure operation expectancy of the pump equipment package is met.

### MEETING SERVICE REQUIREMENTS

Combined cycle power plants can be designed as base-load and/or peaking generating stations. During high load demands, gas turbine exhaust temperatures are increased, raising the system steam pressure and subsequently the electrical output. The pumping systems must be reliable and available at all times (Fig. 4<sup>■</sup>). Often they must meet more than a dozen operating conditions as well as up to 200 starts and stops per year. As boiler ramp-up time is critical, the pumps are expected to handle quick thermal changes without

internal wear or damage. Sulzer engineers fully evaluate the operating system and provide the customer with pump selection and equipment package to suit the most demanding service requirements.

### LONGER PUMP LIFE THROUGH TAILOR-MADE SET-UP

The high-energy pumps used in today's combined cycle power generating plants are highly engineered products. While they are readily available and standardized in hydraulic construction, they still must be properly specified, instrumented, installed and operated to be reliable. The four primary services include boiler feed water, cooling water, condensate and general service applications. Arguably the most critical application is the boiler feed water pump. In base-load operation, the pump is in a state of continuous running

and typically in the most efficient part of the performance range. This mode of operation for multi-stage ring section diffuser pump designs (Fig. 5<sup>■</sup>) is usually handled by a balance disk, sleeve bearing, ring oil lube, Permavor arrangement (Permavor is a lift-off device; see Figure 6<sup>■</sup> and also Sulzer Technical Review 1/1999, p. 4).

In contrast for cycling operation, the pump must meet changing load demands and operate over its full range, including frequent starts and stops as well as speed changes when variable-speed drives are installed. For cycling operation, Sulzer suggests the balance drum, sleeve pivot shoe, pressure lube system arrangement. This set-up ensures maximum reliability and energy savings for the utility as well as longer pump life, because construction features are matched to operating parameters.

### ALLIANCES CREATE SYNERGY BENEFITS

Driven to lower plant design and construction costs, several owner operators, engineering and construction firms use alliance agreements with their supplier base to realize synergy benefits through partnerships. Working with one or two vendors, standard processes, pre-approved drawings and procedures and agreed upon commercial terms ensure a cost-effective, dependable and reliable supplier

5<sup>■</sup> The M-range boiler feed water pump is used in applications with fast changing operating conditions.

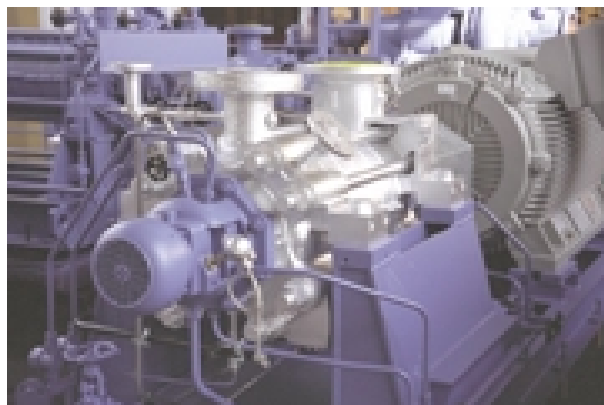

Permavor is seated on the pump shaft and relieves the axial thrust during the starting up and running down (red/blue: magnetic rings of different polarity).

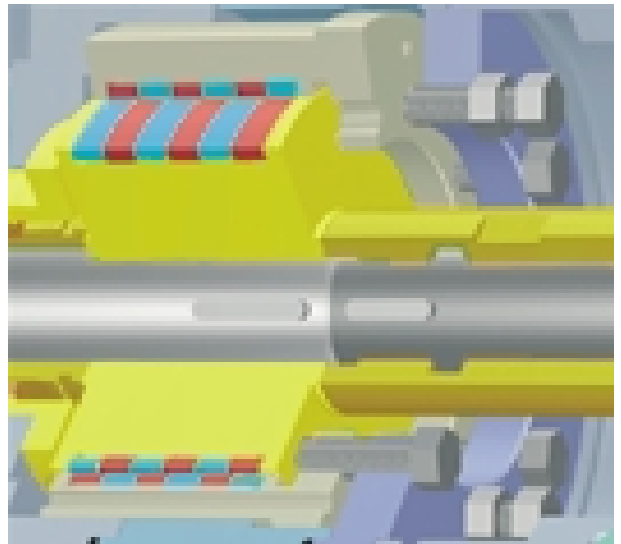

6<sup>■</sup> *Permavor is a patented non-mechanical lift-off device using permanent magnets, thus minimizing stop/start wear of internal components in multistage ring section diffuser pumps to maximize the mean time between maintenance.*

base. Sulzer has broad experience in alliances providing satisfaction and commercial benefit to its partners such as Alstom Power, Bechtel, Siemens, and Washington Group.

### GLOBAL CUSTOMER SUPPORT

With governmental deregulation in many countries, a new breed of power company is emerging, crossing regions and grid boundaries. In Canada and the US, the top-ten power companies each have net equity in excess of 10 000 MW. With ongoing mergers, only a handful of major utilities are going to cover the European market. The

industry will continue to consolidate over the next several years into a few multinational power companies. Sulzer's CSS (Customer Service Support) organization (Fig. 7<sup>■</sup>) is well established to provide global maintenance services to these companies, ensuring availability of the installed pump population.

Centrifugal pump reliability and availability in today's combined cycle power plants is dependent upon proper application, selection of matching features and equipment, shop testing, correct field installation, pump operation training, conducting routine maintenance

and service work. Working with a full-service pump supplier such as Sulzer is essential to reliable pump installations that are indispensable for bringing combined cycle on-demand power to the customer.  $\Omega$

7<sup>■</sup> *Backed by a responsive service network to solve problems and provide maintenance work, Sulzer offers a product life cycle approach supporting the customer from product specification through service life.*

- Divisional headquarters
- Manufacturing facilities
- Customer support service center
- Sales office



### FOR MORE DETAILS

Sulzer Pumps (US) Inc.  
 Doug Filker  
 2800 N.W. Front Avenue  
 P.O. Box 10247  
 Portland, OR 97120  
 USA  
 Telephone +1 (1)503-226 55 47  
 Fax +1 (1)503-226 54 10  
 E-mail [doug.filker@sulzerpumps.com](mailto:doug.filker@sulzerpumps.com)