

K. Meinel*

AHLSTAR^{UP} – A Modern Range of Stock and Process Pumps for Constant Energy Consumption Savings and Enhanced Operational Reliability without Sealing Water

AHLSTAR^{UP} further development of the reliable AHLSTARTM stock and process pumps, also known as APP pumps, used in the pulp and paper industry all over the world.

The continuous improvement of processes in the pulp and paper industry requires better machines, components and pumps.

This leads to a need for enhanced reliability to ensure higher availability and operational safety, extend maintenance intervals, improve cost effectiveness of pumps through a higher efficiency factor and achieve the best possible coverage of the entire pump spectrum to reduce power requirements. Furthermore, it is important to provide designs that are easy and quick to maintain and offer shaft seal concepts that are dependable without needing sealing water.

There is also an increasing demand for more standardization and compatibility of modular structures, both to reduce the cost of spare part inventories and to be able to adjust the performance of existing pumps to new operational conditions by exchanging hydraulic components.

Sulzer Pumps took these needs as their guide for the development of the AHLSTAR^{UP}.

The foundation for this ongoing development has been, and still is, long-standing experience and knowledge about the specific processes and requirements of the pulp and paper industry.

This stock pumping concept is again a part of the Sulzer product family for various applications in the pulp and paper industry, in pulp production, pulp drying machine, chemical recovery, stock treatment, short circulation for the paper machine and the paper machine itself as well as waste water clarification (Fig. 2).

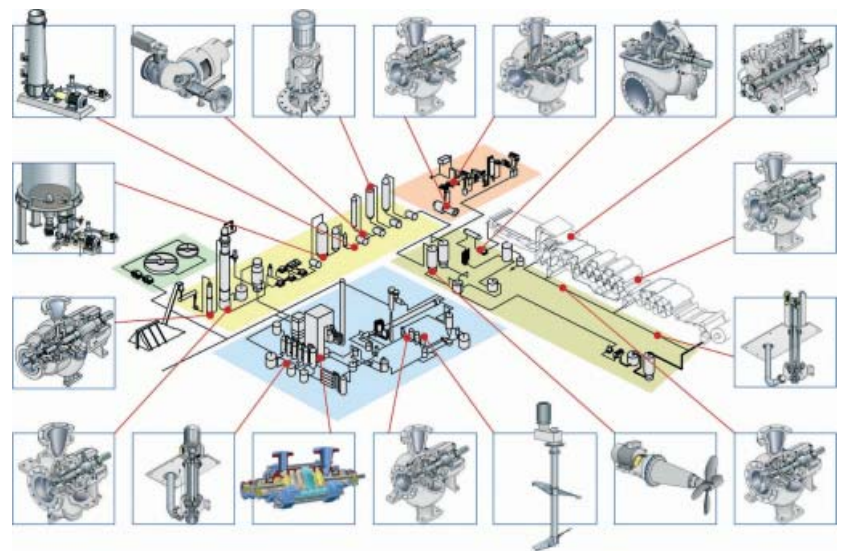

Fig. 2: Product family pumps, agitators and mixers

1. Sulzer Stock Pumping Concept

AHLSTAR^{UP} is part of the Sulzer stock pumping concept, which also comprises KCETM, LCETM and MCETM pump systems (Fig. 1).

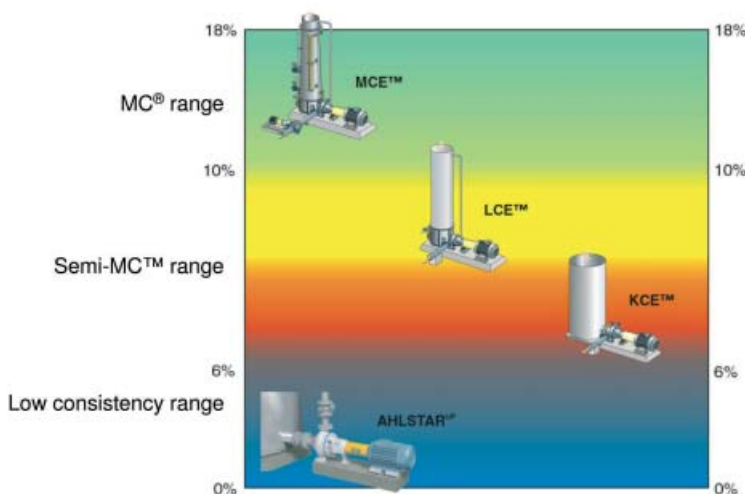

Fig. 1: The Sulzer stock pumping concept

2. New Hydraulics

There was a comprehensive catalogue of requirements for the new A-hydraulics of the AHLSTAR^{UP}. Amongst the following key elements were identified:

- High efficiency over a wide performance range.
- An impeller design that can pump clean, abrasive and corrosive liquids and stock of various kinds up to a stock consistency of 8%.
- A second impeller that can pump stock up to a consistency of 8% and liquids with long or large solid particles.
- Good coverage of the entire pump spectrum by an optimal number of pump sizes.
- High suction capability and low NPSHr over a wide performance range.
- To optimize the entire hydraulic range while maintaining the size of the pump, increase the hydraulic performance, capacity, head and efficiency of the AHLSTAR^{UP} compared to the AHLSTARTM and to reduce the NPSHr-value.
- An externally adjustable side plate to maintain high efficiency throughout the pumps working life.
- To reduce wear caused by the pumped liquid using a design optimizing flow in the pump. (Fig. 3).
- Maintain specific hydraulics, e.g. N-hydraulic for pumping liquids with large or long solid particles or W-hydraulic for pumping highly abrasive and erosive liquids such as lime mud (Fig. 4).

*Kurt Meinel; Sulzer Pumpen (Germany) GmbH; Sales Office Kirchheim; Heinkelstrasse 19-21; 73230 Kirchheim/Teck; Germany; www.sulzerpumps.com
Presentation at Exhibitor-Seminar Zellcheming 2006

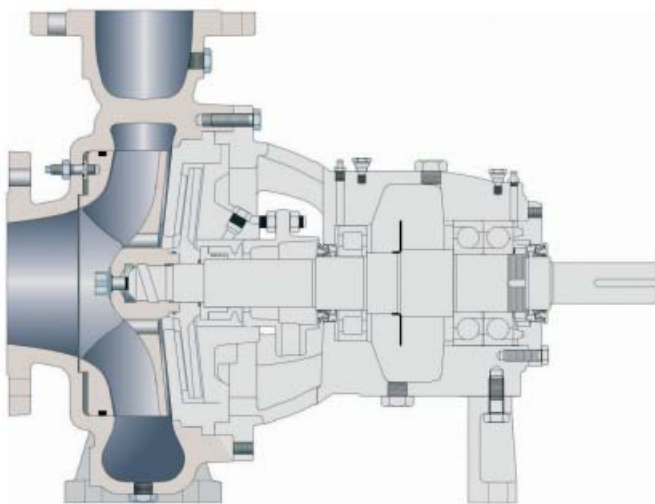

Fig. 3: Flow optimized shape

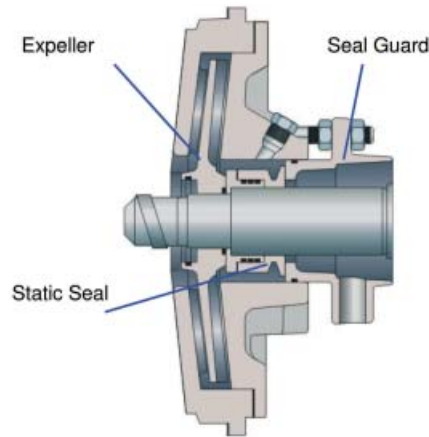

Fig. 5: Dynamic Seal

sealing liquid or wastewater treatment. The new static seal prevents solid particles from entering through the sealing gap and reduces operational wear (Fig. 5). More than 30,000 pumps in the pulp and paper industry worldwide have been

equipped with dynamic seals to date.

3.2 Mechanical Seals

The single mechanical seal does not require any external sealing liquid. By introducing a special design feature there is continuous lubrication by the liquid pumped.

The double mechanical seal always needs external sealing water. By using SmartFlow more than 90% of the sealing liquid can be saved (Fig. 4).

All parts of the mechanical seals are always installed to the end stop, no measuring needed, which prevents installation mistakes.

4. Sulzer Selfprime & Degas™ Concept (self-priming and degassing)

Since the processes in the pulp and paper industry have been continuously improved, e.g. higher speed, shorter storage periods in smaller chests, etc., the content of gas and air in the stock has increased.

Sulzer has already applied the so-called “gas separating pump” with external vacuum pump and the

“self-priming pump” with internal vacuum pump for these problematic applications. Both systems had been revised before they were integrated into the AHLSTAR^{UP} and are available for all three hydraulic series (A-, N- and W-hydraulic) (Fig. 6).

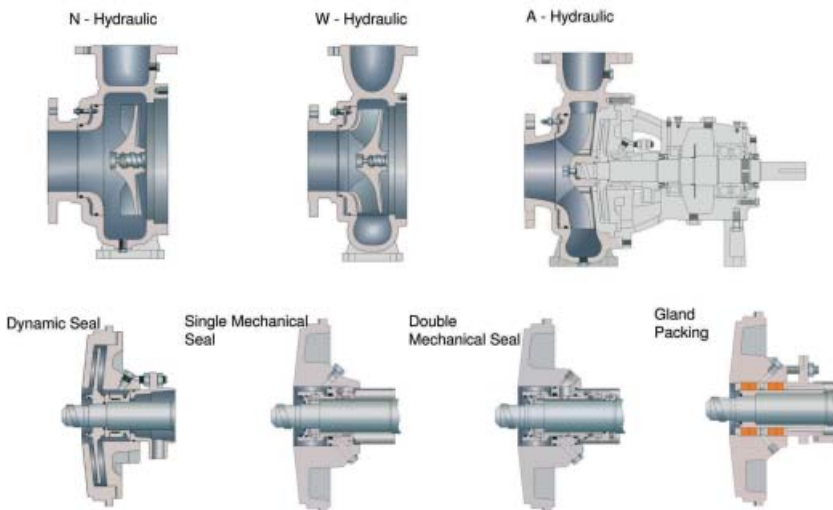

Fig. 4: Hydraulics of AHLSTAR^{UP} and interchangeability of the Shaft Seal Concept

3. Sulzer WaterLess™ Shaft Seal Concept

The shaft seal deserves special attention because it accounts for about 65% of all problems with pumps. (summary of experience from different industrial branches).

Sulzer has already considered this point by developing and introducing dynamic seals for the AHLSTARTM.

Since dynamic seals can not be used in certain applications, Sulzer developed the WaterLessTM Shaft Seal Concept for the AHLSTAR^{UP}. The complete WaterLessTM Shaft Seal Concept features improvements on the reliable dynamic seals plus single and double mechanical seals which were developed in cooperation with John Crane Safematic.

The shaft seals have common dimensions and can be readily exchanged due to the modular design of the AHLSTAR^{UP} with A-, N- and W- hydraulics when they have the same size bearing unit (Fig. 4).

AHLSTAR^{UP} pumps can also be equipped with gland packing, although this type of sealing is rarely used.

3.1 Dynamic Shaft Seal

This is a non-contact seal solution that does not need any sealing liquid (sealing water) and therefore does not need any system for the

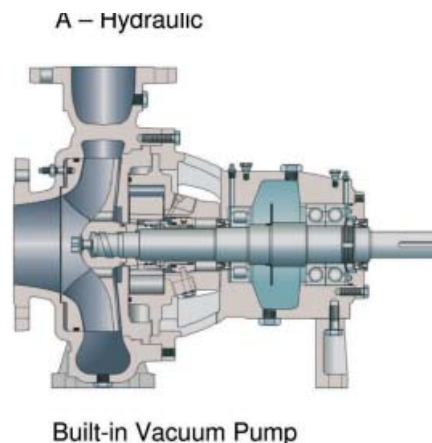

Fig. 6: Selfprime & DegasTM Concept +

5. Sulzer Bearing Unit Concept

Oil and grease lubrication are possible.

“Inpro SealTM”, used to seal the bearings, is a reliable and wear-free labyrinth seal, which is used on both sides of the bearing unit (Fig. 3).

6. Installation

We kept the proven torsion-resistant T-shaped base plate fixed at three locations. Part of the standard delivery package are adjusting

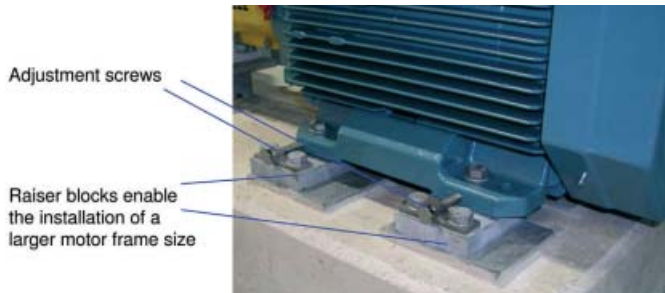

Fig. 7: Adjustment screws facilitate and speed up coupling alignment

screws for an easier alignment of the motor and raiser blocks for later installation of a larger motor frame size (Fig. 7).

7. Exchangeability of AHLSTAR™ (APP) with AHLSTAR^{UP}

AHLSTAR^{UP} and AHLSTAR™ (APP) pumps are exchangeable as both have identical external key connection dimensions. The performance of an existing AHLSTAR™ APP can be increased by exchanging the casing, impeller and the side plates with AHLSTAR^{UP} (Hydrofit). Installed AHLSTAR™ pumps can also be converted to the WaterLess Shaft Seal System or the new Bearing Unit Concept (Retrofit).

8. Sulzer Environmental Concept

Environmental considerations have also been of priority for these innovations and changes.

Lower power consumption, almost no leakage both of the liquid pumped and the oil or grease used for lubrication plus no or an extremely low demand for sealing liquid mean protection of resources and the environment (Fig. 8).



Fig. 8: AHLSTAR^{UP} – the Environmental Pumping Concept

9. Summary

AHLSTAR^{UP} is a further development of the market leading AHLSTAR™ stock and process pumps that are installed in the pulp and paper industry worldwide. The high reliability of AHLSTAR™ has been increased by

- Optimizing shaft sealing with new systems (single and double mechanical seal)
- New static seal arrangement for the dynamic shaft seal
- Revising gas separation of the “degassing pump”
- Improved wear resistance through new hydraulics (casing and impeller)
- Higher reliability of the bearing unit through better lubrication and bearing sealing
- Completely revised hydraulics with higher efficiency factor, lower NPSHr-values and better performance
- Modular AHLSTAR^{UP} exchange units to fit existing AHLSTAR™ pumps, e.g. complete pumps, exchange units and bearing units.

become

ideas

reality

GAW is constantly pushing the borders in paper technology. Today GAW helps papermakers all over the planet creating products to bring your ideas to reality.

FAST FORWARD technology

www.gaw.at

