

Dynamic Seal in the Sugar Industry: Enhanced Operational Reliability and Lowest Total Costs

Shaft Sealing

The dynamic seal increases the operation reliability of shaft sealing in an economical way. Expensive and sensitive mechanical seals can be eliminated as well as cord packings, which require high maintenance costs over the pumps lifetime. Dynamic seal needs no external sealing liquid, which means easiness of operation, and less costs.

Until now, the shaft seal has been the most maintenance intensive component of a centrifugal pump. While the use of a mechanical seal instead of cord packing for sugar juices and other difficult liquids have brought considerable improvements, significant operating and maintenance problems remain.

Conventional cord packings and mechanical seals will wear due to mechanical friction during running and will eventually form a leak path. These seal types require a steady supply of sealing liquid for lubrication and cooling purposes, and often this liquid comes from an outside source. There is a risk of disorders in the supply of sealing liquid, in which case the seal will have to run dry, consequently can lead to rapid seal damage and stopping of the pump. In many cases, it is necessary to stop the pump unexpectedly, which causes considerable costs.

Therefore, cord packings and mechanical seals require frequent maintenance, and the selection of mechanical seals has to be done very carefully; the range of different construction and material alternatives is great. Mechanical wear, leakage and the need for sealing liquid have been practically eliminated with the introduction of the dynamic seal for AHLSTAR™ pumps for more than 10 years. The dynamic seal is used for all paper stock consistencies and other difficult liquids containing solids.

Operational Reliability

The dynamic seal gives considerable improvement in operational reliability. Thanks to its simple yet strong design, the seal lasts as long as the other pump parts exposed to the liquid pumped. The materials available include all the same cast materials as are used for the pressure parts of the pump. This contributes to the compatibility of the parts also under corroding circumstances.

Some important aspects in terms of operational reliability:

- There is no sudden and unanticipated malfunction as may be the case with mechanical seals.

Need for sealing liquid:

- Cord packing 4 l/min
- Mechanical seal, single 2 l/min
- Mechanical seal, double 2 l/min
- Dynamic seal 0 l/min

Power consumption:

- Cord packing 0.4 kW
- Mechanical seal, single 0.15 kW
- Mechanical seal, single/quench 0.1 kW
- Mechanical seal, double 0.3 kW
- Dynamic seal 0.8 kW

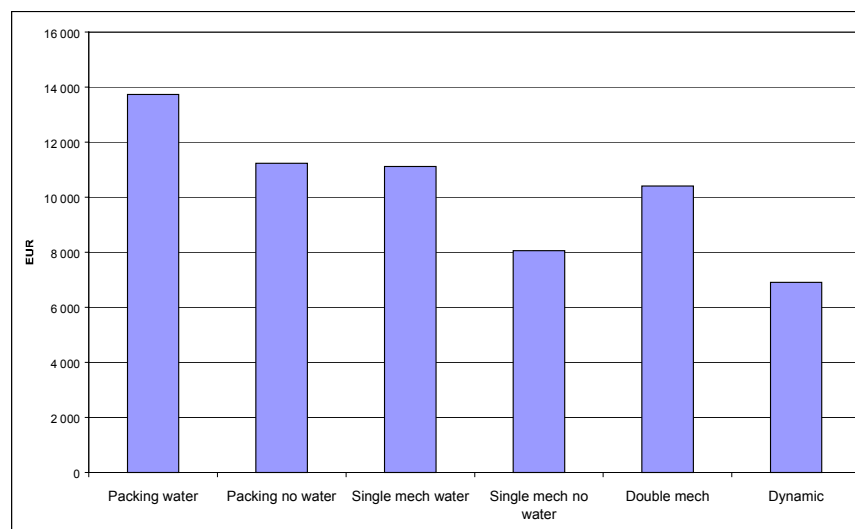

Graph 1. Operating costs over a lifetime of 10 years

Significant operating costs in sealing are caused by constant monitoring and maintenance need, replacement of worn parts as well as consumption of sealing liquid and electricity. In some applications, evaporation costs for excess sealing or flushing liquid may also be quite high.

The operating costs are highest with seals requiring a sealing liquid. The prices of sealing liquid vary greatly between various mills, but the essential thing is to consider the production, investment and disposal costs of sealing liquid as they are actually accrued. As far as maintenance costs are concerned, it should be remembered that cord packings require adjustments and change of parts during their lifetime, thus increasing the costs of packed stuffing boxes. The attached calculations have been made under the assumption that the cord packings in packed stuffing boxes are replaced during normal shutdowns.

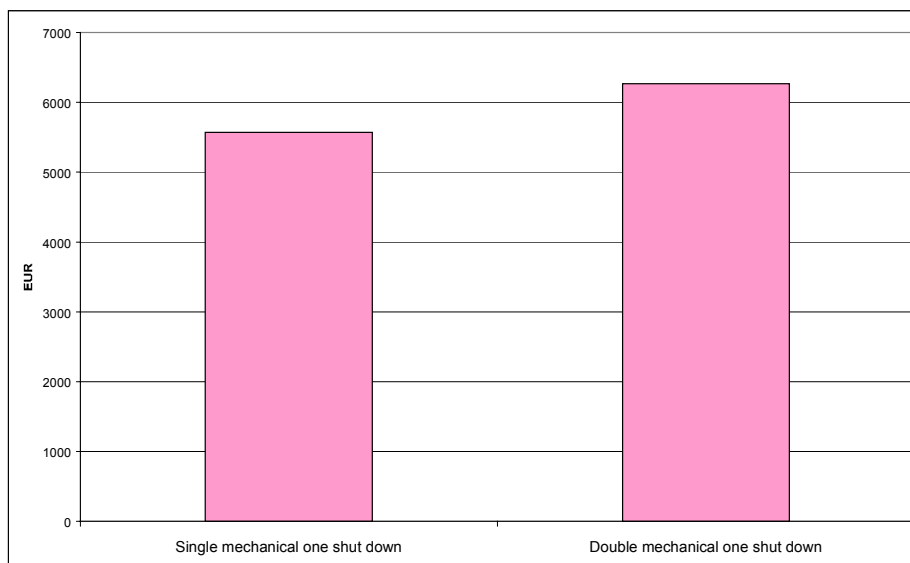

Graph 2. Unexpected shutdown costs for mechanical seals.

Significant costs are created in continuous process industries when unexpected faults occur in equipment included in the main process. In the worst case, the entire plant has to be stopped during full production at an unfavorable time of the day. When calculating the costs, the things that need to be taken into account include production loss caused by the shutdown, process product wasted as a result of the fault, necessary spare parts and their replacement work, and extra monitoring and reporting. Moreover, it takes some time to start the line again and to achieve a normal production pattern. The final costs of the shutdown grow very high if it is difficult to obtain the spare parts for some reason, consequently extending the shutdown.

Graph 2 shows that the costs of one shutdown with mechanical seal are of the same magnitude as the costs of the dynamic seal over a lifetime of 10 years refer graph 1. The biggest individual cost item is the loss of production caused by the stopping of the process.

Dynamic Seal in AHLSTAR™ Pumps

Sulzer Pumps has supplied dynamic seals since 1987. Since then, the number of applications has grown very rapidly. Almost one half of AHLSTAR™ pumps delivered in recent years have been provided with the dynamic seal. In addition, there are numerous pumps into which the dynamic seal is installed as retrofit using the conversion kit which includes the parts required by an existing pump, see figure 3.

Simple Operation

When the pump is running, the expeller generates centrifugal forces, which form a liquid ring in the expeller seal chamber. This liquid ring becomes the shaft seal and prevents leakage. The expeller rotates freely in its chamber without any mechanical friction and also without mechanical wear. When the pump stops, the liquid fills the seal cavity and presses the flexible disc against the sleeve, thus preventing leakage. When the pump starts again, the expeller generates a liquid ring in the expeller seal chamber and removes the liquid from the seal cavity. The flexible disc is no longer pressed against the sleeve.

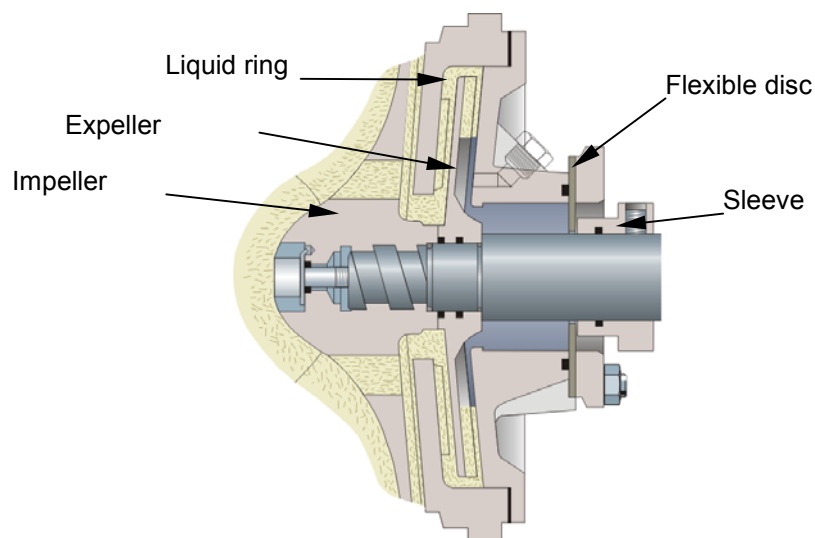

Fig 1. Dynamic seal in operation

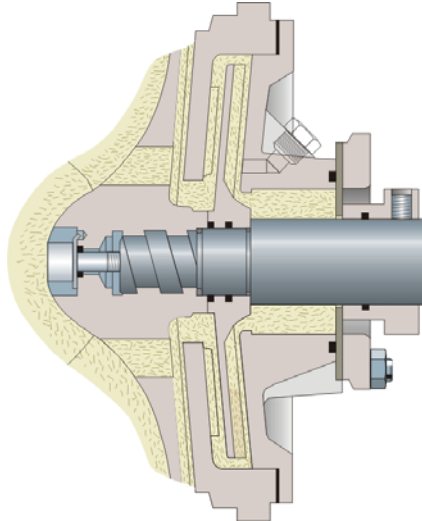

Fig 2. Dynamic seal at standstill

Conversion of Existing Pumps to Dynamic Seal

Existing AHLSTAR™ APP, NPP or WPP pumps, originally installed with mechanical seal or cord packing, can easily be converted to the dynamic seal. No machining is necessary; all that is required is an interchange of parts. Overall, pump dimensions are the same, so the pump and motor remain in the installed position. The conversion kit includes the expeller, casing cover, seal chamber, complete static seal and all necessary auxiliary seals and screws.

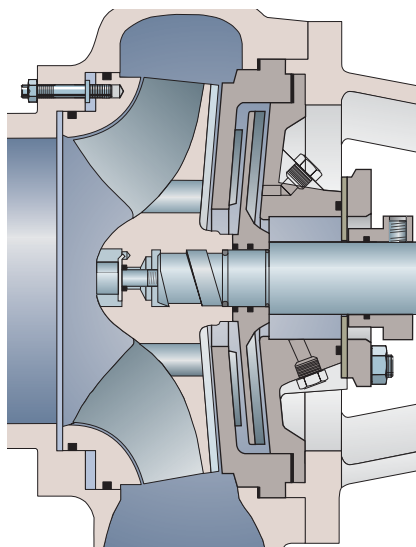

Fig 3. Conversion kit parts for the dynamic seal.

Selection Criteria

The dynamic seal can be chosen for most process industry applications as a primary option. In the selection, the issues to be considered are the type and temperature of liquid pumped and inlet pressure level.

The following factors restrict the use of a dynamic seal:

- With standard construction the temperature of the pumped liquid must be below boiling point. With special construction higher temperatures are allowed.
- The permitted inlet pressure value depends on the rotating speed of the pump and on the size of the expeller.
- In the sealing of environmentally hazardous substances with the dynamic seal, careful consideration should be used, since the dynamic seal is a relatively open solution and the liquid is in contact with the atmosphere.
- When a prolonged shutdown begins, the piping is normally flushed, whereby the dynamic seal of the pump is also sufficiently flushed. In some cases, it is recommended to flush the seal chamber when a shutdown begins. Shorter shutdowns do not require flushing.

Summary

The dynamic seal essentially improves operational reliability and costs accrued during the operation of a pump. There are no unexpected faults affecting production due to the simple and strong design of the dynamic seal.

Mechanical wear and leakage of the seal as well as the need for sealing liquid have been practically eliminated. The Sulzer Pumps' dynamic seal is suitable for almost all pumping applications in sugar mills and other difficult liquids containing fibers and solids.

For further information, please contact:

Food-info.pumps@sulzer.com