

SULZER

Sulzer Pumps

OHC Canned Motor Pump



OHC Pump

API 685 Canned Motor Pump

SULZER

Sulzer Pumps

The OHC canned motor pumps represents the ultimate in pressure containment with 2 full pressure boundaries and static sealing.

The OHM magdrive is next in line with primary static containment shell and gas seal secondary.

The OHH conventional API 610 pumps provide security with mechanical sealing technology.

All use the Sulzer OHH family of hydraulic components.

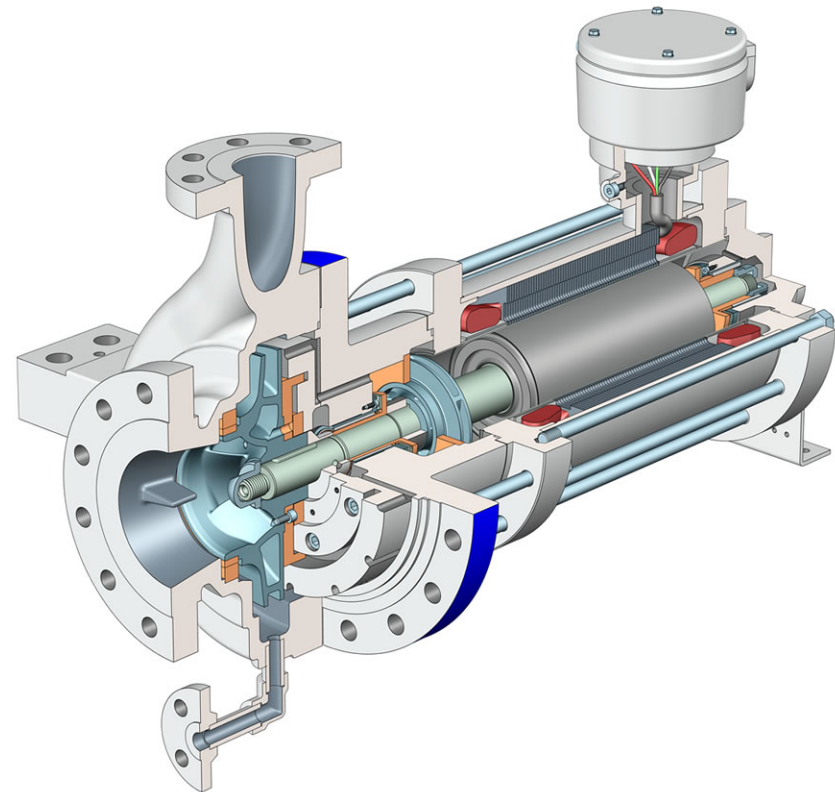

OHC: Hermetic's Canned Motor teamed with Sulzer's Hydraulics

SULZER

Sulzer Pumps

- Casing, impeller casting and front wear rings are interchangeable with OHH API 610 pump.
- Enclosed, dynamically balanced impellers are provided for increased efficiency.
- Over 40 different hydraulics with 11,000 Nss or less.
- Optional impellers in most sizes for lower NPSHr.
- Axial thrust is controlled by Hermetic's unique thrust balance device with over 100,000 in service for many years.

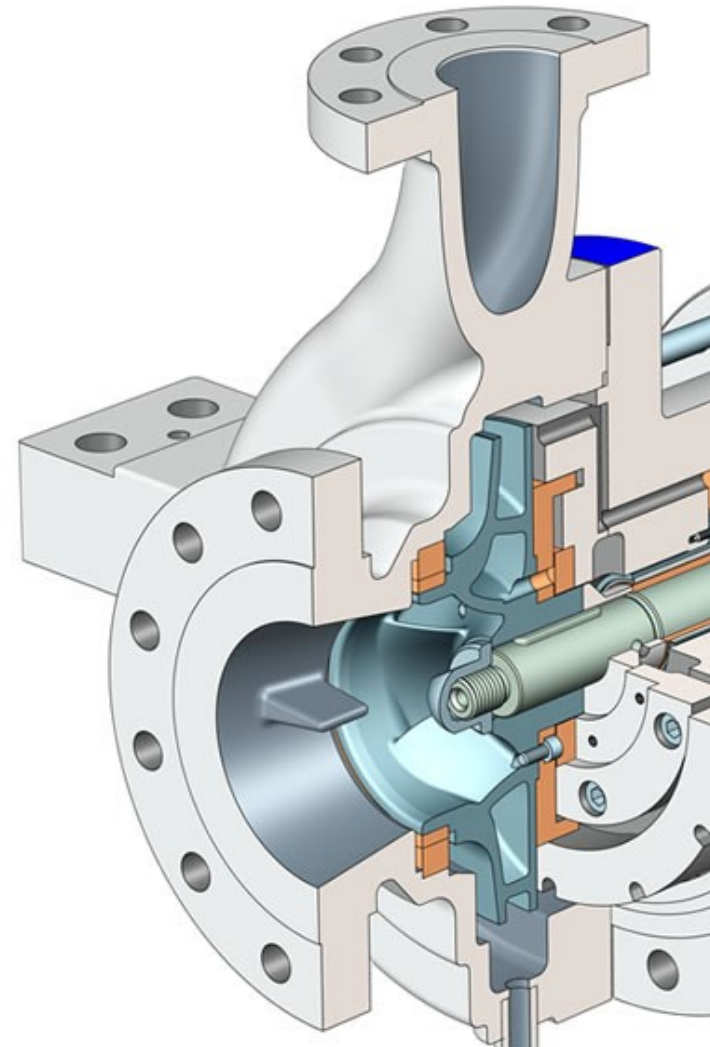

OHC Performance

2950 rpm

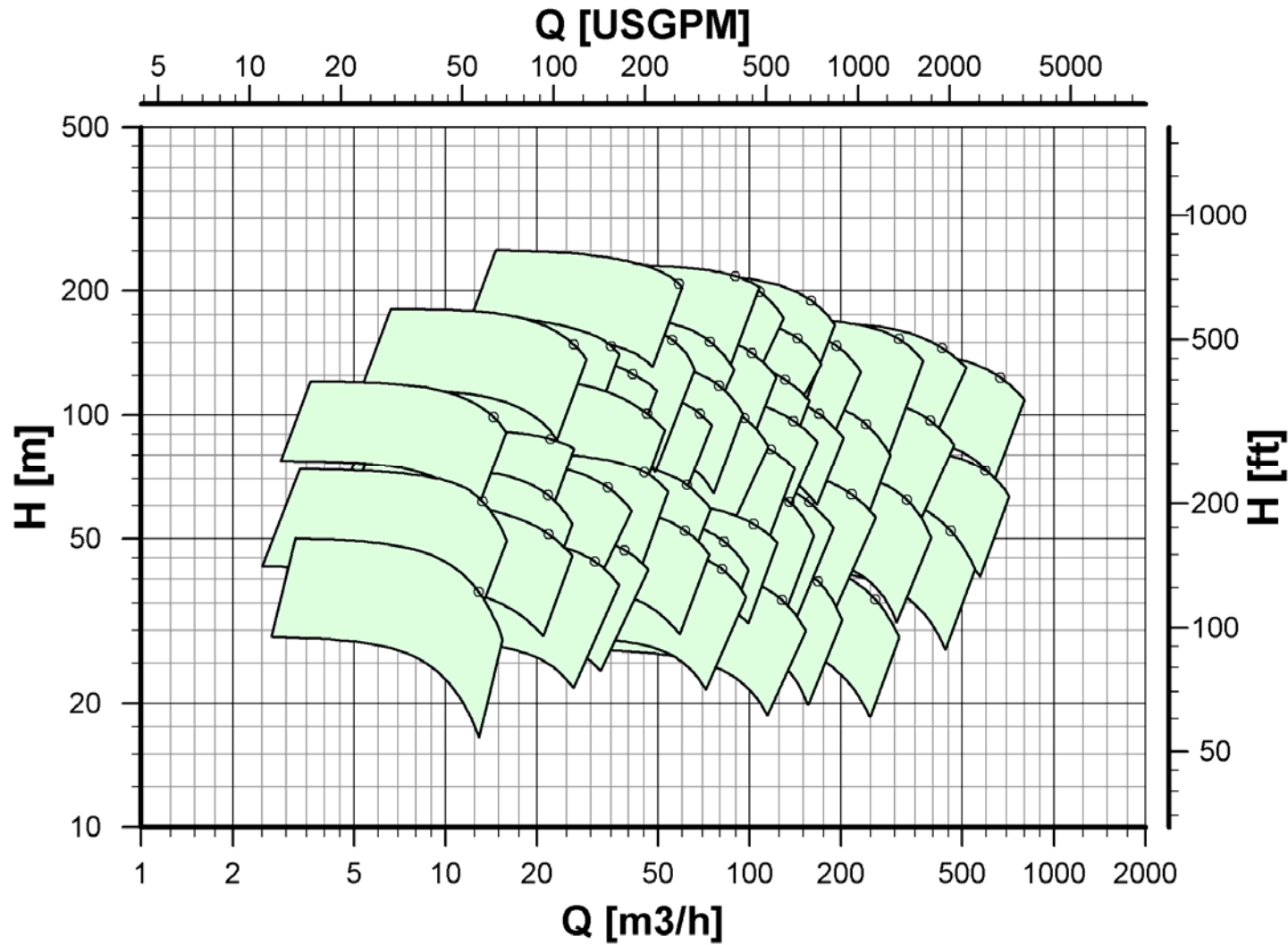

OHC Performance

1475 rpm

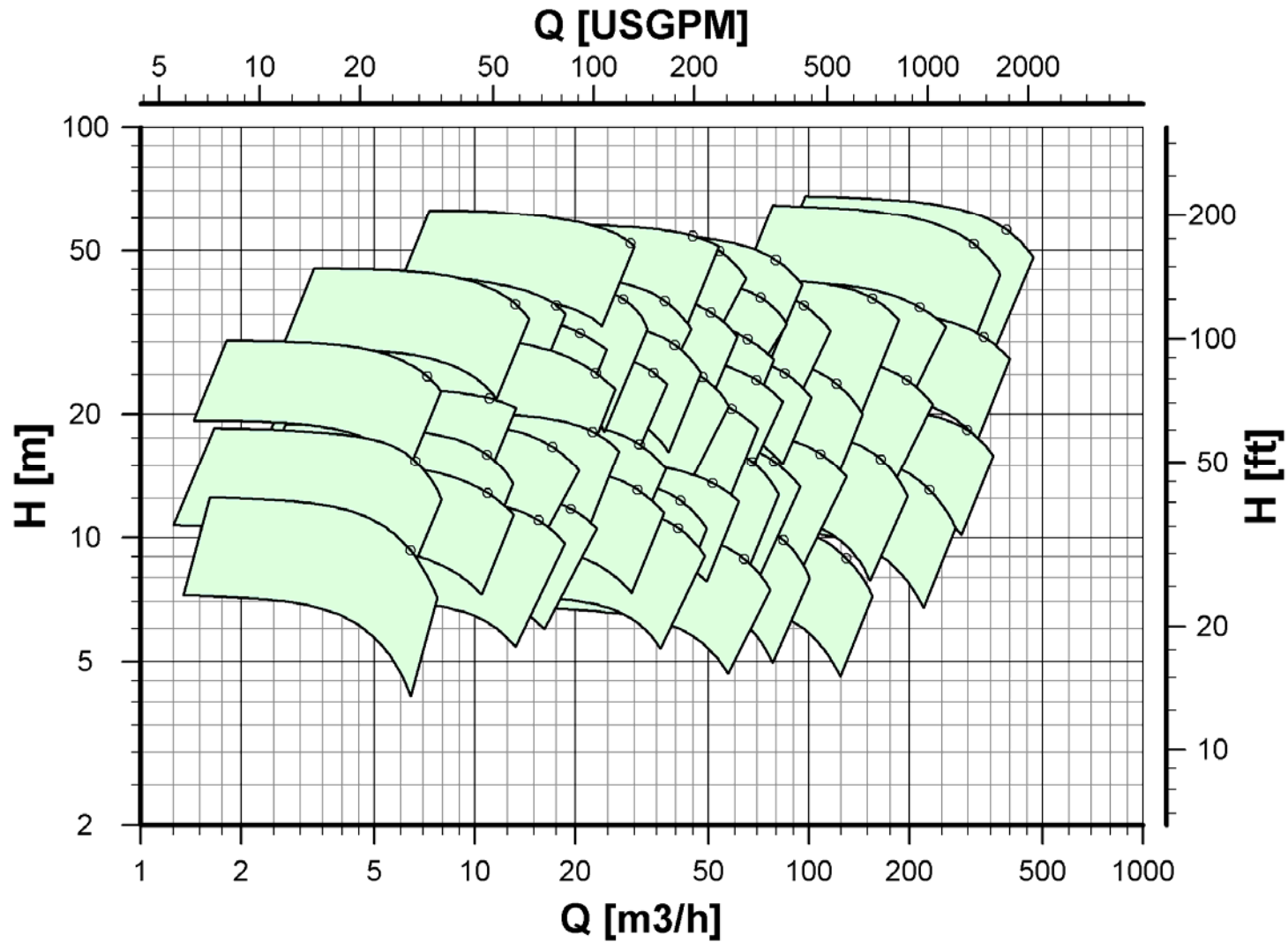

OHC Performance

3550 rpm

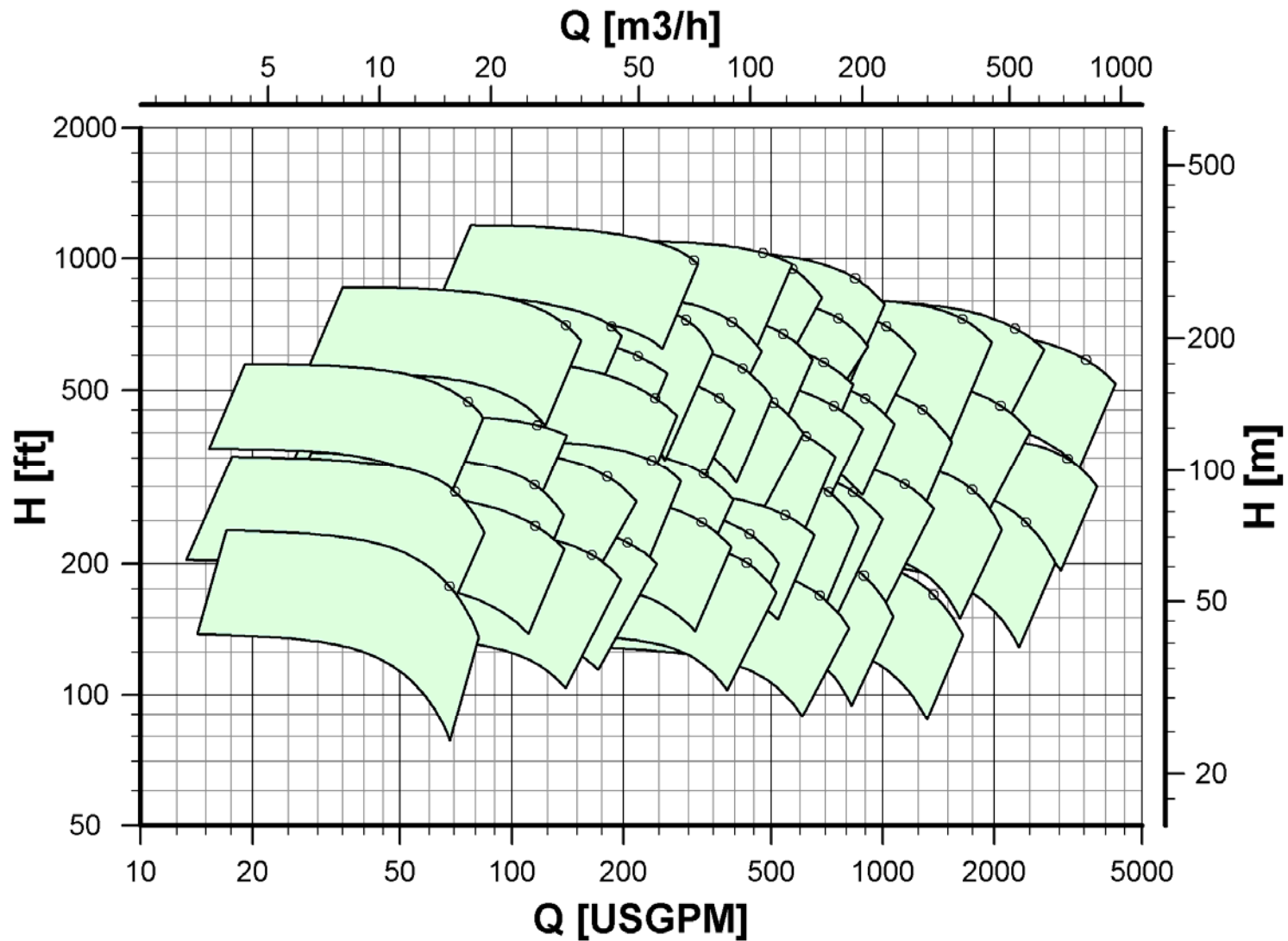

OHC Performance

1775 rpm

SULZER

Sulzer Pumps

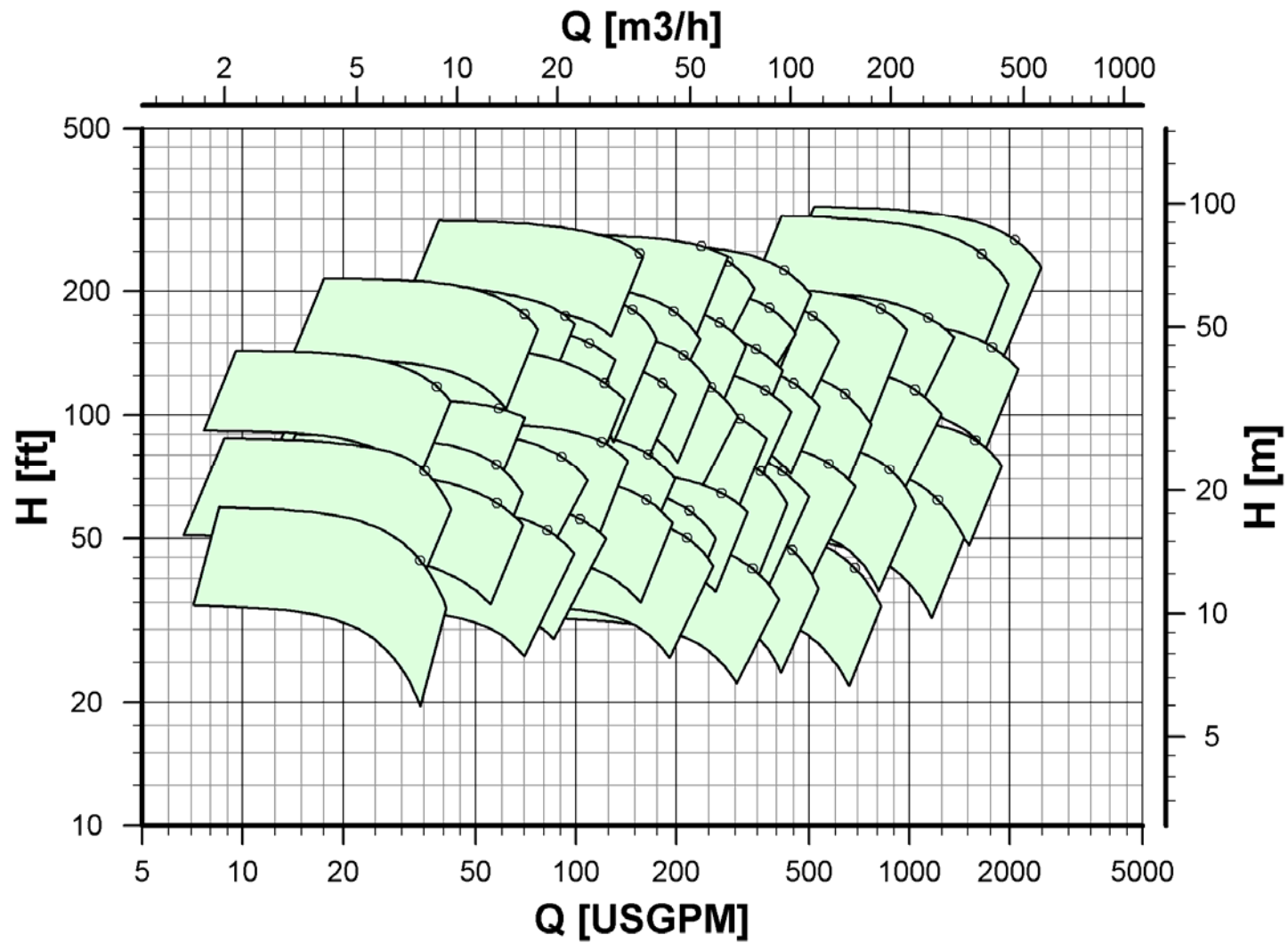

OHC Design Features

Volute Casing

SULZER

Sulzer Pumps

- Pressure boundary components designed to ASME Section VIII - with 3 mm (1/8") corrosion allowance per API 685.
- Self-venting, centerline discharge.
- Double volutes for larger sizes.
- Confined controlled compression gasket with metal to metal rabbet fit.

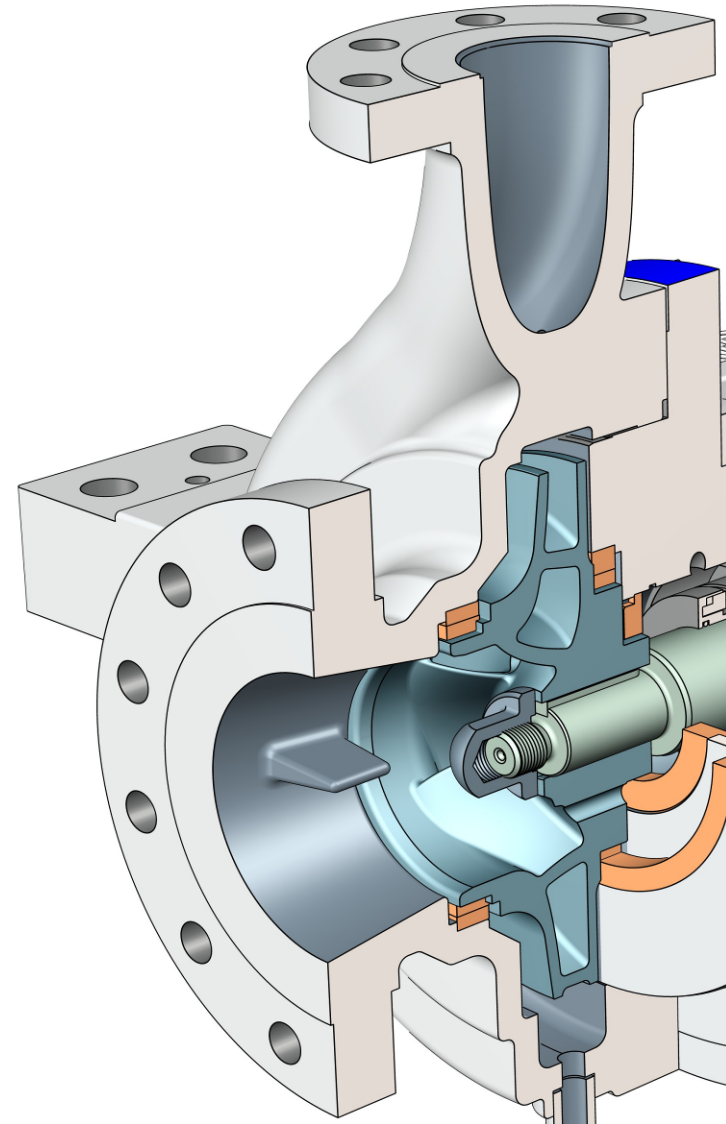

OHC Design Features

Flanges & Nozzle Loads

- Casing mounting feet are designed to meet ISO 13709 (API 610) or API 685 nozzle loads.
- 2 x API 685 nozzle load capability is available.
- Since leakage and alignment are not issues of concern with the OHC, standard pump support structure is normally used.
- Flanges are normally 300# raised face and backfaced as required by API 685.
- DIN / ISO flanges are available.

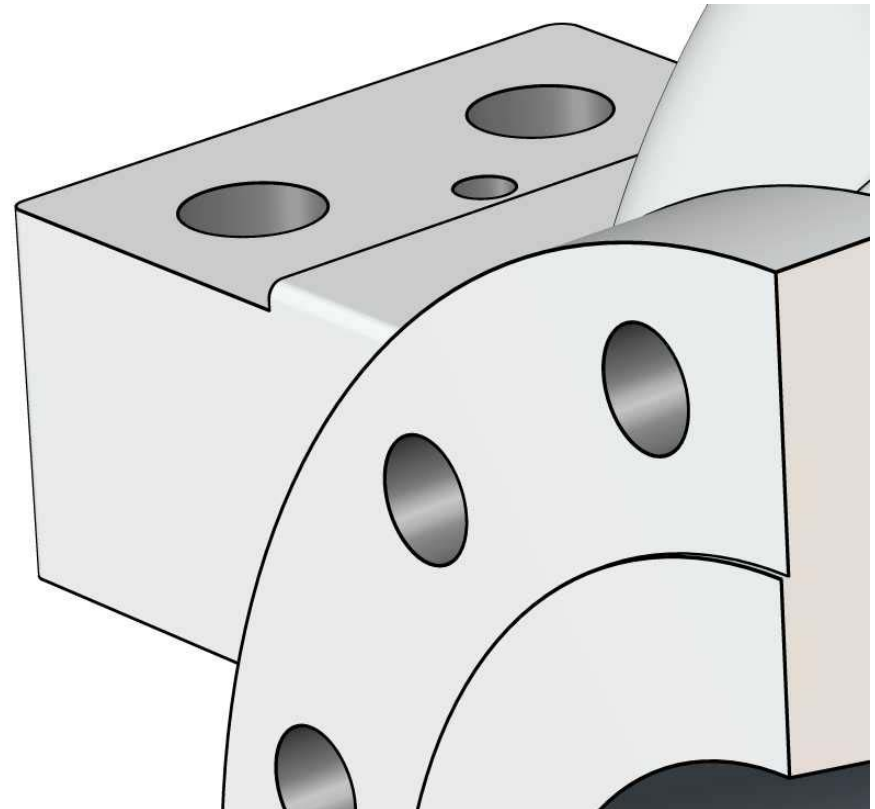

OHC Design Features

Axial Thrust Compensator

Thrust compensator is effective over entire operating range

How it works:

- Any decrease in suction pressure forces rotor toward suction side and closes variable throttle.
- Pressure in balancing chamber drops.
- That lower pressure forces rotor toward motor, which opens variable throttle.
- In reverse case rotor reacts with a corresponding thrust towards suction.

Compensator is therefore self-equalizing and virtually unaffected by wear or fluid viscosity

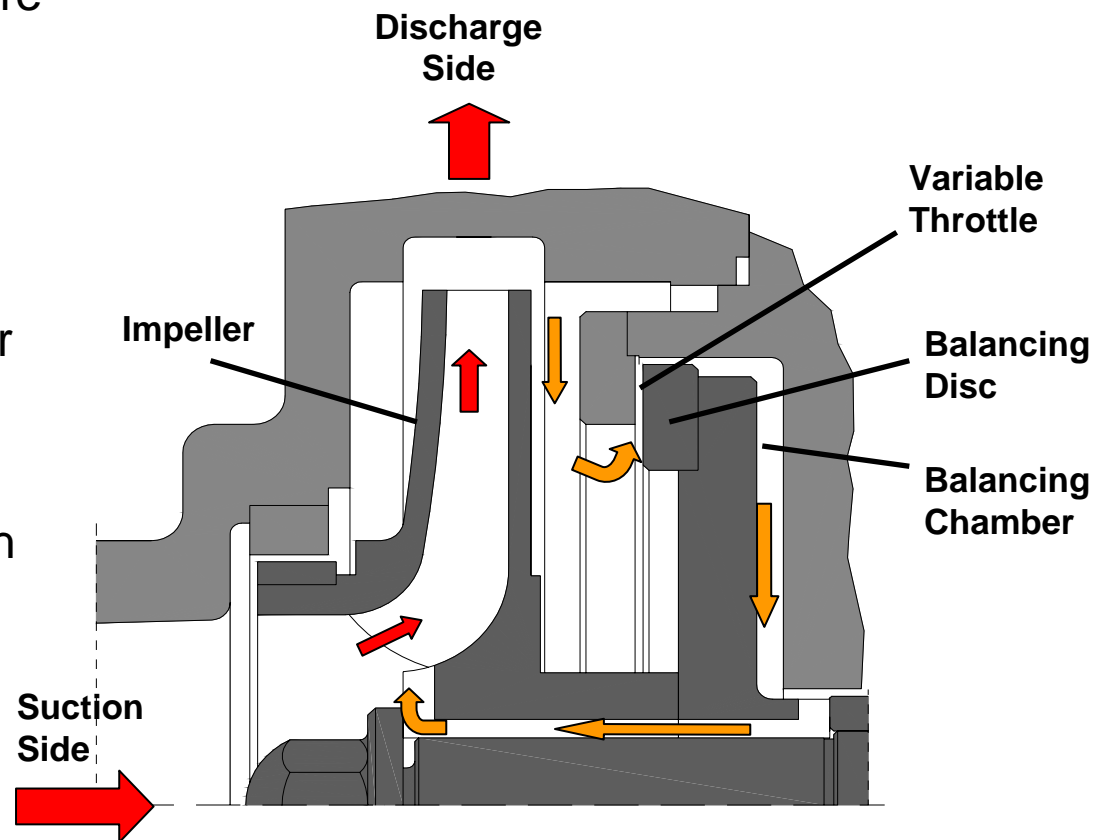

OHC Design Features

Bearing System

- Canned motor pumps are inherently axially balanced since both ends of the shaft are exposed to suction pressure.
- In the OHC, the Hydraulic thrust compensator takes most of the axial thrust load; grooved thrust pads take the remainder.
- The OHC rotor is supported in Silicon Carbide bearings with Teflon/Carbon residual thrust pads
- Shaft is protected by a Tungsten Carbide coated stainless steel sleeve at each bearing

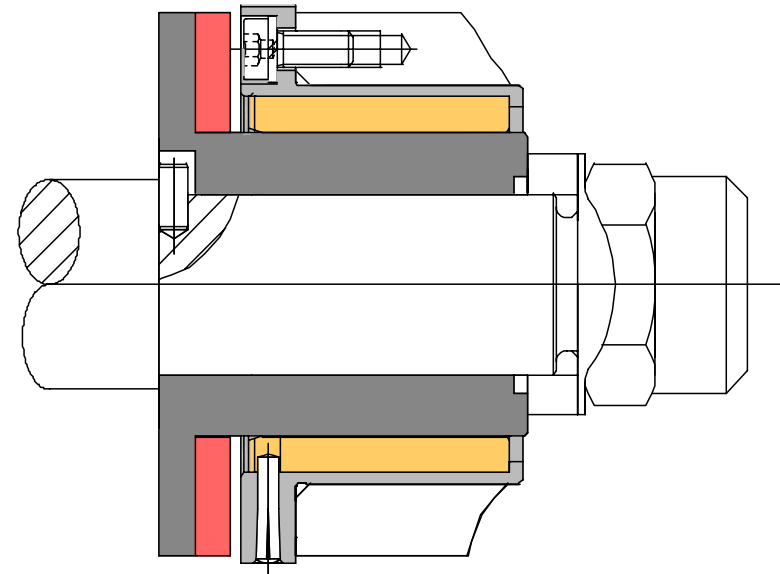

OHC Design Features

Circulation Flow Paths

3 Flow paths cover virtually all applications

- Standard flow is from impeller discharge through the motor and exiting into the impeller eye.
- For fluids near their vapor pressure, an auxiliary impeller is used to boost pressure within the motor cavity. Flow exits radially thru the shaft behind the impeller into a pressurized zone to avoid flashing.
- Depending upon power rating and ATEX temperature class, either ceramic insulation, or aux impeller and heat exchanger are used for high temperatures.

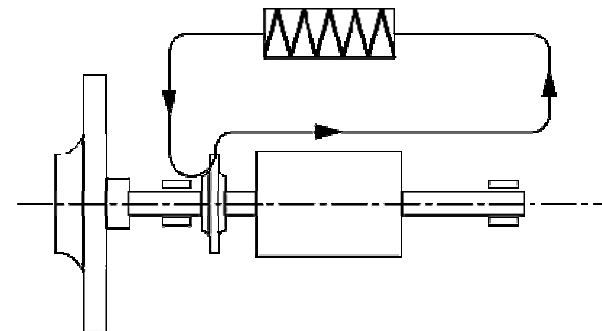
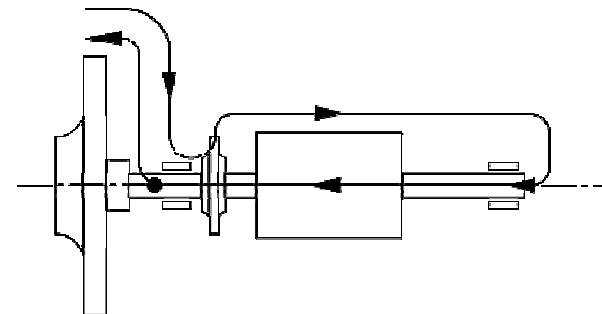
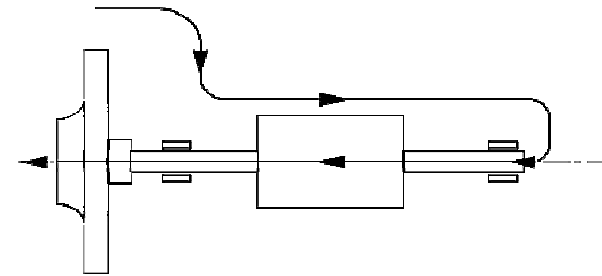

OHC Design Features

Canned Motor Types

SULZER

Sulzer Pumps

- Standard Motor is designed for services up to 100° C (212° F).
- Adding the heat exchanger and auxiliary impeller extends its capability to 427° C (800° F).
- Up to 360° C (680° F), depending upon power rating and ATEX temperature class, ceramic insulation can be used to provide longterm operability without the need for cooling water.
- Motors are certified to the new European Explosion Proof requirements – ATEX.

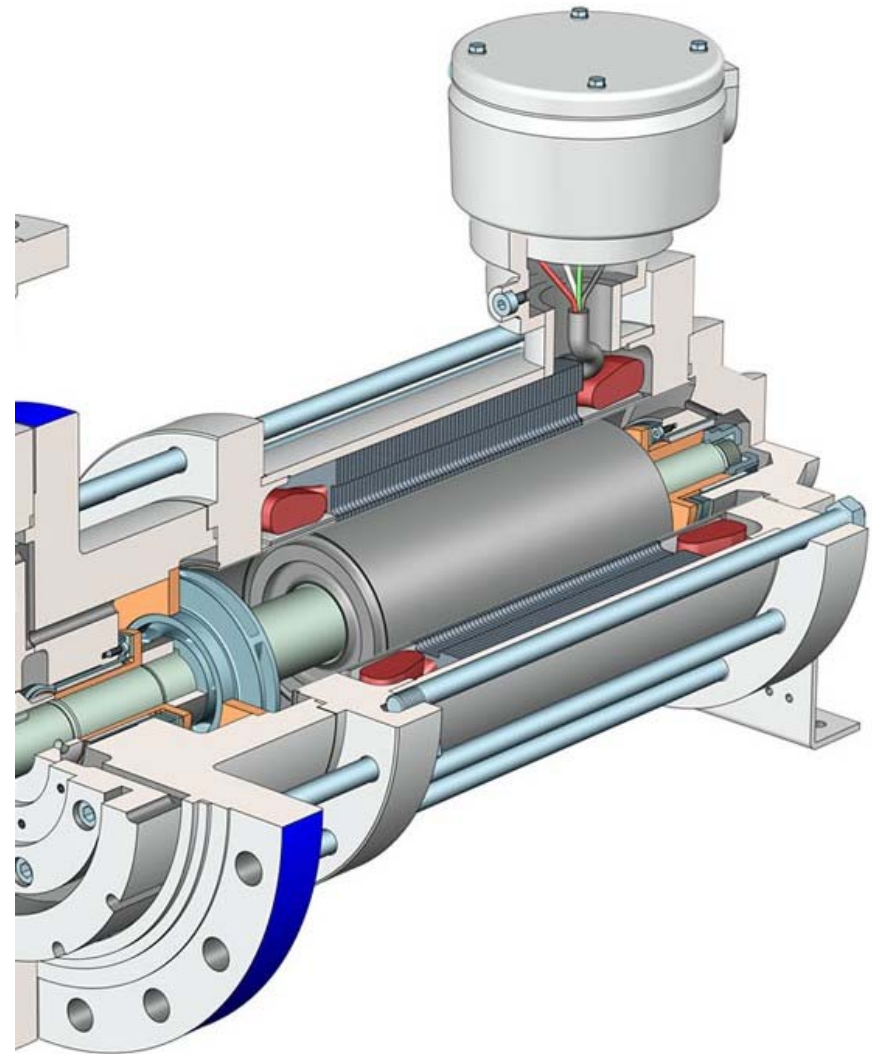

OHC Design Features Secondary Containment

- Hastalloy stator liner is welded to SS stator endcovers to form a permanent pressure boundary.
- Armature cover is welded SS or Hastalloy depending upon application.
- Secondary containment is formed by CS motor casing, conduit box, and endcovers.
- If some foreign object causes a stator liner breach, the full pressure secondary containment will contain it.
- Motor tie bolts are not part of primary pressure boundary; they are for rigidity.

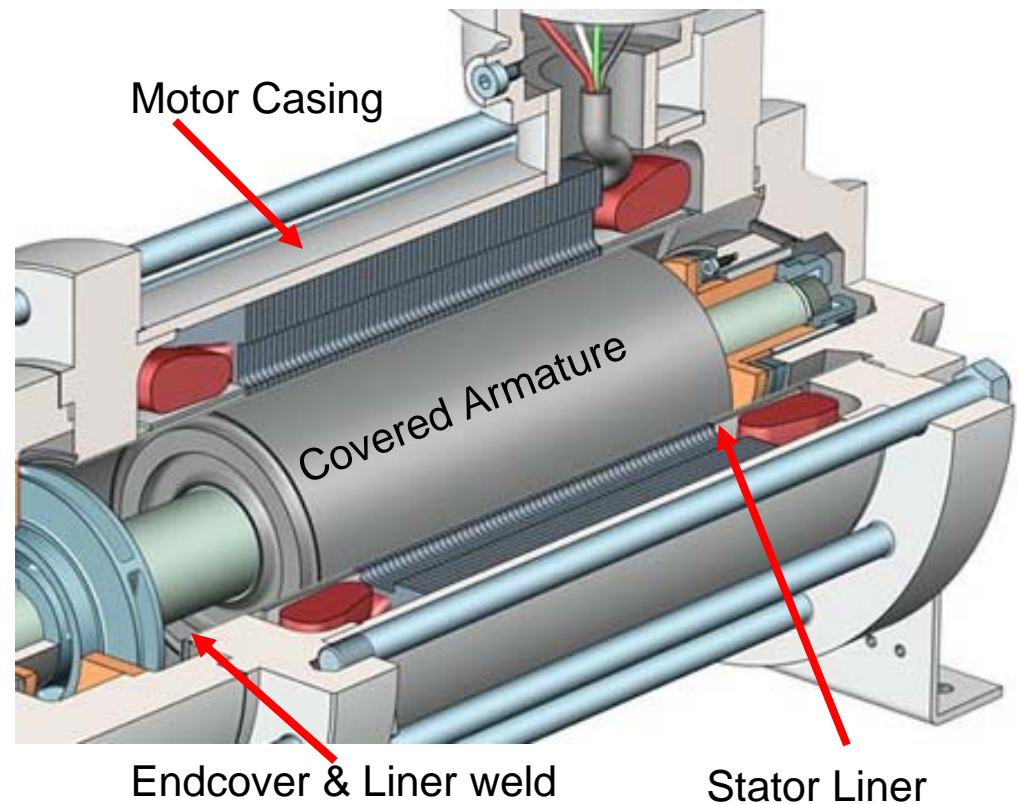

A variety of instrumentation is available for pump protection, rotor position and rotation direction

OHC

Manufacturing & Testing

SULZER

Sulzer Pumps

- OHC hydraulic components are machined on multi-axis CNC machining centers.
- Hermetic's Canned Motors are built to exacting standards near Freiburg, Germany.
- Each assembled pump is tested at Hermetic before shipment.
- A variety of pump and motor testing is available to meet specific requirements as well as API 685



OHC Applications

- Aromatics
- Phosgene
- Carbon Dioxide Loading
- Ethane Loading
- LPG transfer or booster
- Dowtherm circulation
- Freon/134A refrigerant transfer
- Cryogenics
- Deethanizer reflux
- Demethanizer reflux
- Amine, Acids, Caustic, Sulphur
- The normal ISO canned motor pumps are available for lower pressures. Hermetic also builds canned motor pumps to over 1000 bar (15,000 psi)

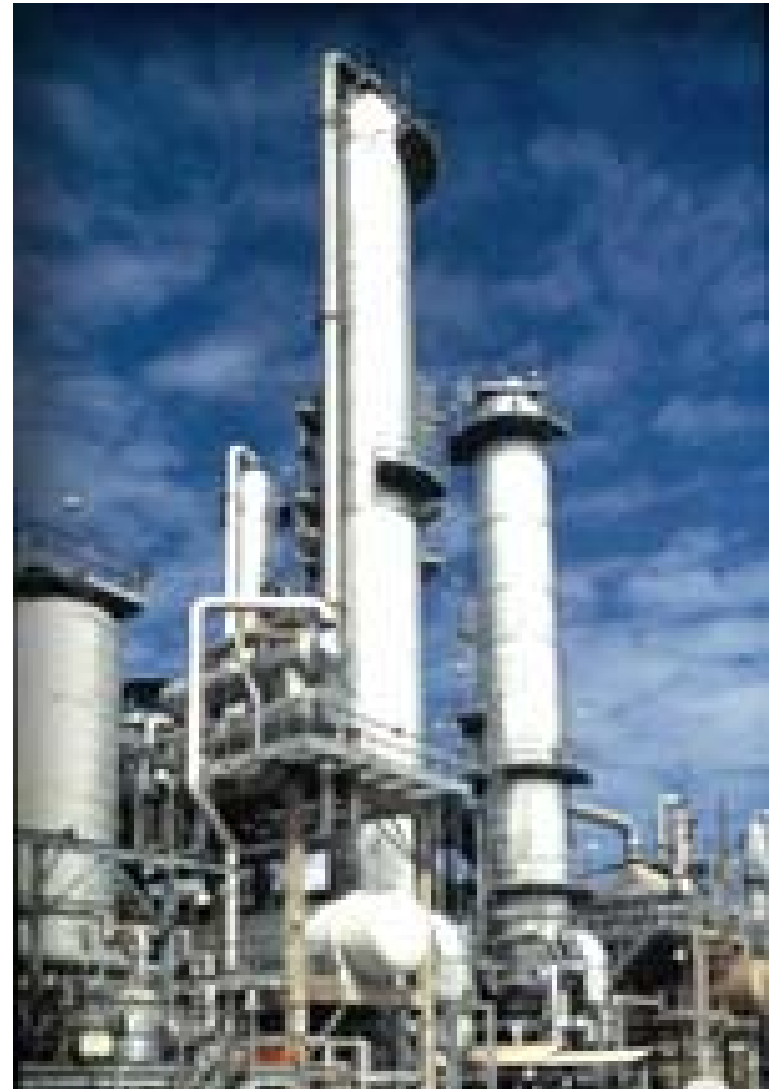

OHC Experience

- Hermetic is believed to be the largest industrial canned motor supplier in Europe and has sold over 100,000 canned motor pumps in the past 30 years.
- Virtually all the major chemical and refining companies have installations; many on toxic or critical service.
- The Sulzer OHC hydraulics are a combination of the Sulzer ZE and CAP8 pumps from Europe and America.
- Over 13,000 of those pumps are installed around the world.
- The OHC represents the best in canned motor technology combined with the best in API pump hydraulics.

