

SULZER

Sulzer Pumps

HPDM Axially Split Volute Casing Pump

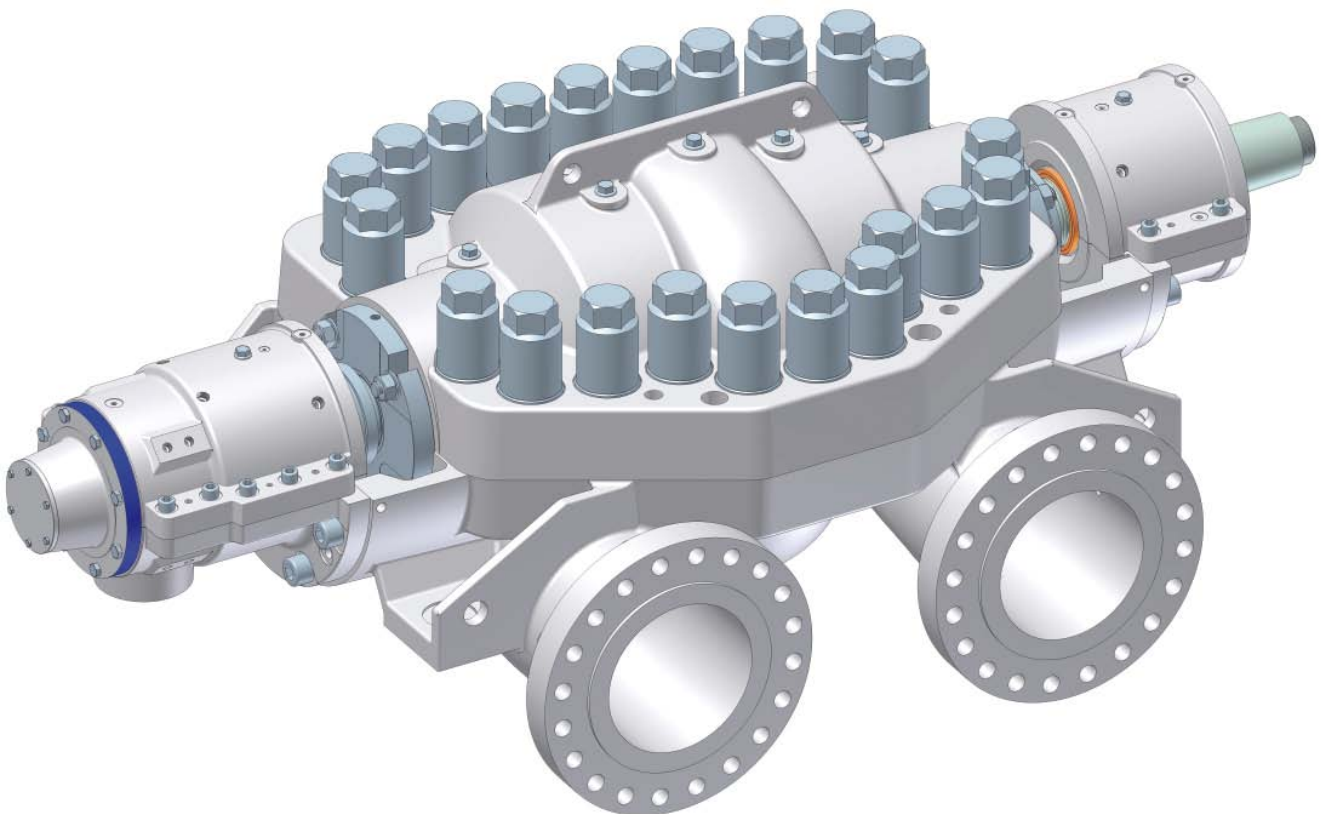

The Heart of Your Process

Sulzer Pumps

Sulzer Pumps is a world leader in reliable products and innovative pumping solutions. Our advanced research and development, detailed process and application knowledge together with a comprehensive understanding of market demands keep us consistently at the leading edge of technical development. Our global network of modern manufacturing and packaging facilities together with sales offices, service centers and representatives located close to major markets provide fast responses to customer needs.

Sulzer Pumps has a long history of providing innovative pumping solutions to business partners in the following industries:

- Oil and Gas
- Hydrocarbon Processing
- Pulp and Paper
- Power Generation
- General Industry
- Chemical Process Industry
- Water and Wastewater

HPDM Global Manufacturing Facilities



Jundiai, Brazil



Leeds, UK

Knowhow for Better Efficiency

Pipelines are commonly the most cost effective and safe way to transport large amounts of liquids over long distances. Pipelines are extensively used to bring water from remote sources to where it is needed or to transport liquids such as crude oil or refined hydrocarbon products from production point to consumption—often across national boundaries.

Sulzer Pumps has been a partner for pipeline pumps for many years and we have demonstrated our experience with hundreds of HPDM pumps supplied to customers

around the world, which represents an installed power in excess of 2.5 GW.

Pumps are at the core of liquid transportation networks. They need to combine high efficiency, high reliability and sturdiness and yet have to be easy to install, operate and maintain. Their longevity is of utmost importance.



Optimum Design Tailored to Duty

HPDM single or multistage, axially split pumps are with horizontal shaft designed for high volume, high pressure transport applications. The suction and discharge nozzles are positioned in the lower casing and although horizontal nozzles are standard, other nozzle positions can be supplied as needed to fit the pipe layout. HPDM pumps are individually designed to provide class-leading efficiency and are used to supply water for arid areas inland, for injection applications, and as main pipeline pumps for crude oil transport.

Our engineers work closely with the customers to provide recommendations on arrangements either with or without booster pumps, series or parallel operation, operating speeds, metallurgies, drivers and start/stop procedures.

Each HPDM is tailor-made to match your needs and is available in various arrangements to suit all requirements of the application. Every pump is designed in 3D CAD and casing integrity is finite elements checked.



HPDM s+s water transport pump



HPDM 1d crude oil transport pump

HPDM Impeller Arrangements

HPDM 1d single stage, double suction arrangement

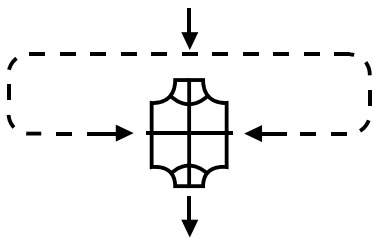

HPDM s+s two stage arrangement with two single suction impellers back-to-back

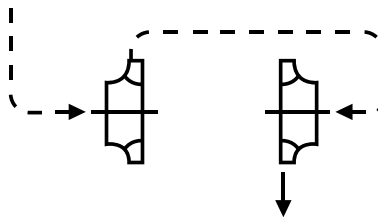

HPDM d+s+s three stage arrangement with a double suction impeller and two single suction impellers back-to-back

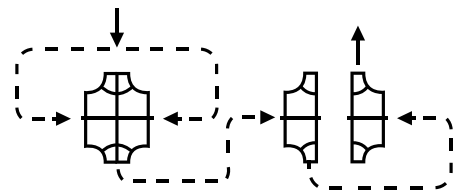

HPDM 2d two stage, double suction, with two double suction impellers in back-to-back arrangement

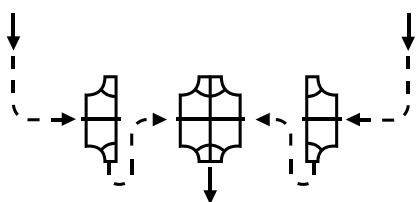

HPDM d+s two stage, double suction arrangement with one double suction and one single suction impeller

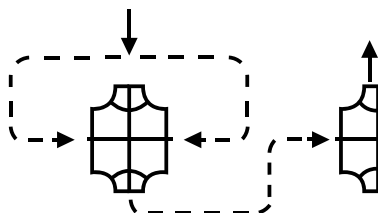

HPDM dd single stage, double suction arrangement with two double suction impellers

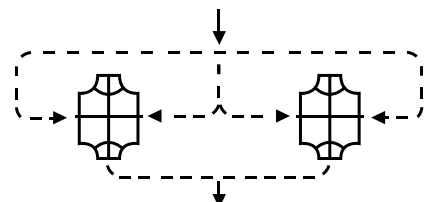

HPDM Design Features and Benefits

2d Arrangement

Hydraulics

- Wide choice of hydraulics
- Enables high efficiency and good suction performance

Wear Rings

- Replaceable wear rings for both casing and impeller are standard

Shaft Seals

- Mechanical seal is standard
- Gland packing seals are optional
- ISO 13709 (API 610)/API 682 mechanical seals are available

Bearings

- Journal radial bearings with double acting thrust pad bearings and pressure lubrication are standard
- Antifriction bearings are optional

Bearing Housing

- Axially split bearing housing allows easy inspection

Twin Suction Impeller First Stage with Diffuser

- In back-to-back arrangement for low NPSHR
- Balance of axial thrust
- Compact diffuser design compensates radial thrust
- Efficient flow to the center double suction impeller

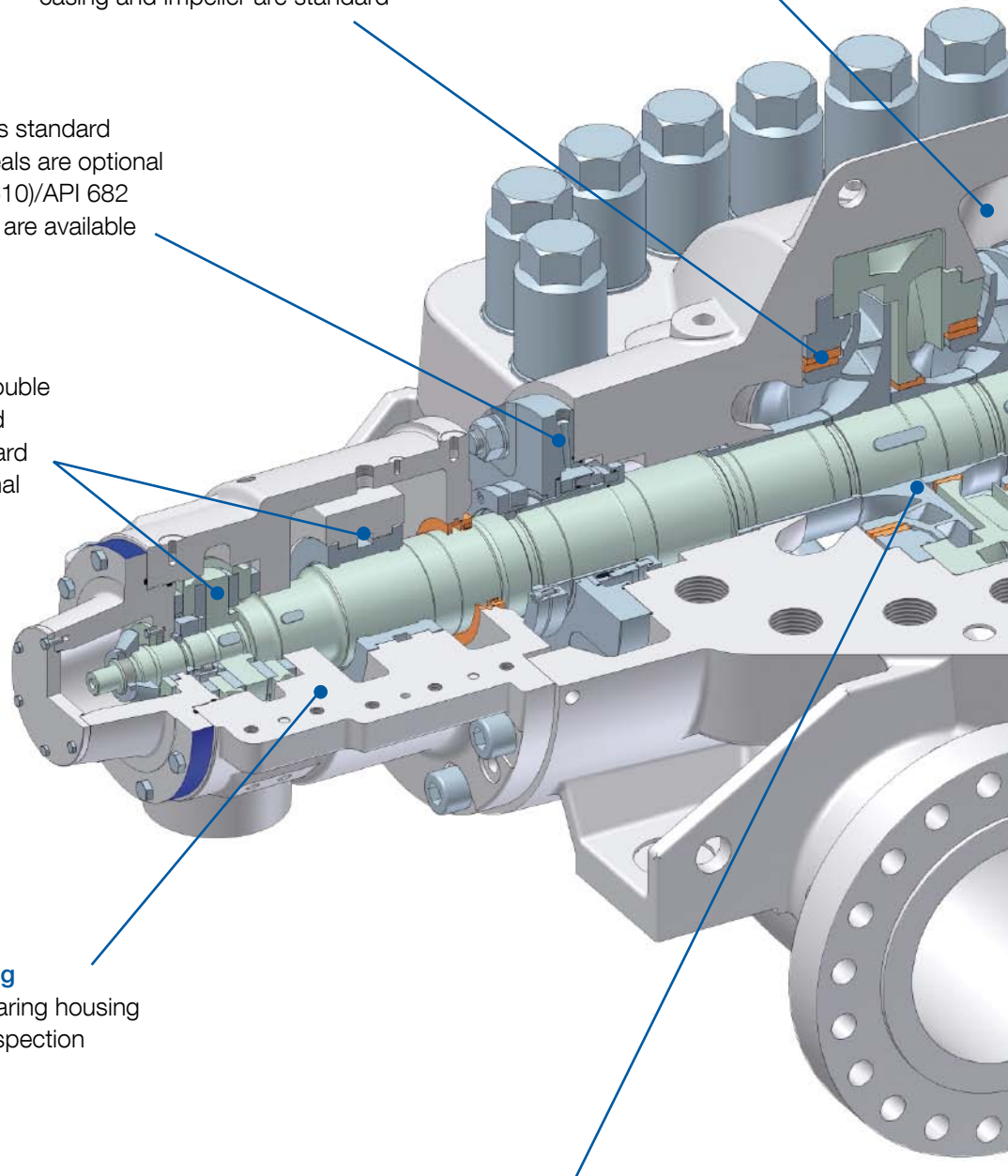

Bushings

- Interstage bushings reduce interstage leakage
- Improved efficiency

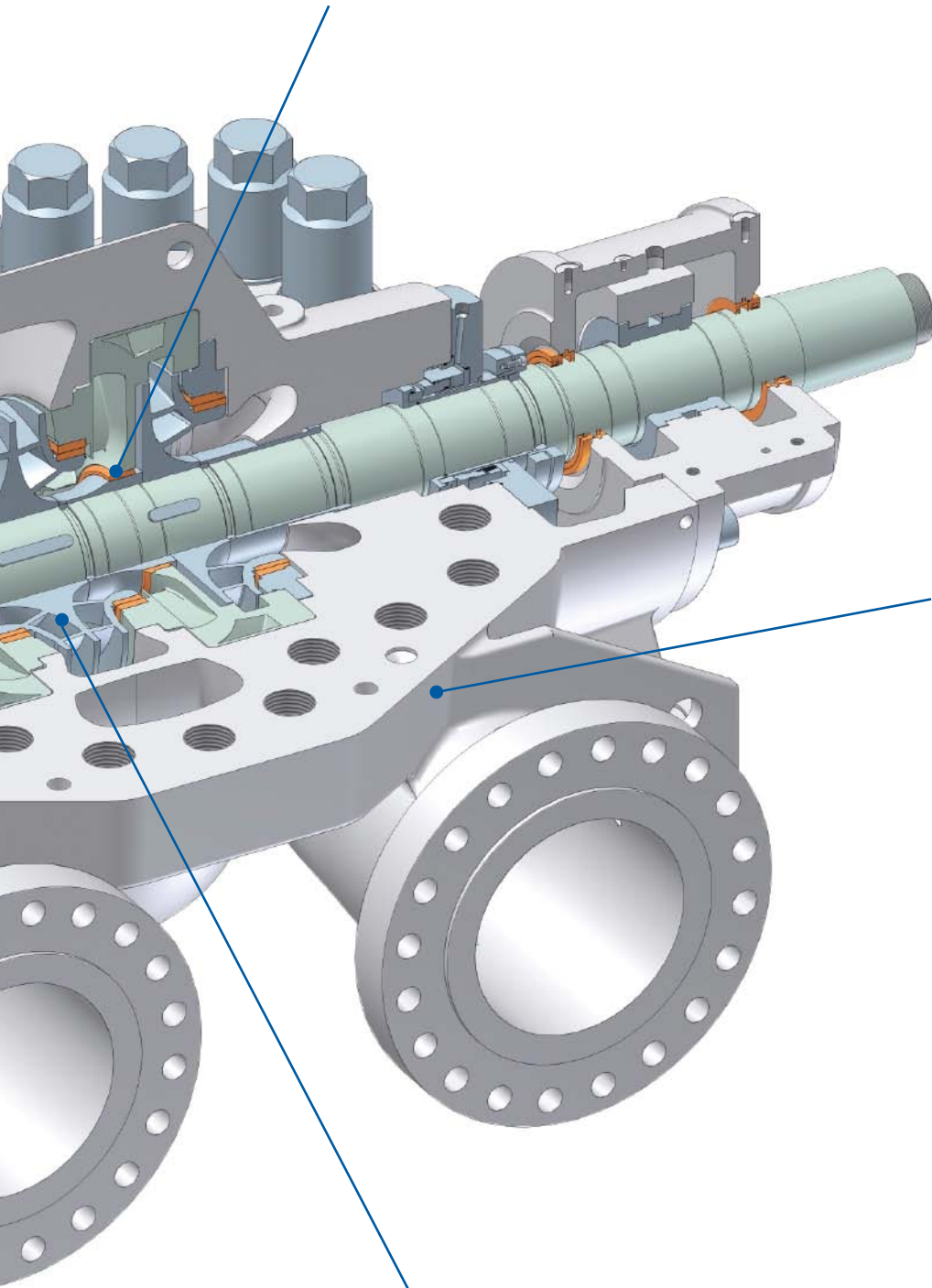

Casing

- Casing integrity at high pressures assured by generous split flange thickness with heavy bolting and face gasket

Double Suction Center Impeller

- Staggered vane design allows high efficiency and low pressure pulsation
- Double volute compensates radial load

HPDM Design Features and Benefits d+s Arrangement

Hydraulics

- Selection of specific speed within a wide range of hydraulics available
- Compact arrangement of short cross-over and cross-under efficiently conveys flow to second stage

Second Stage

- Single suction
- Optimum combined efficiency
- Double volute compensates radial load

First Stage

- Double suction impeller with staggered vanes for high efficiency, good NPSH and low pressure pulsation
- Double volute compensates radial load

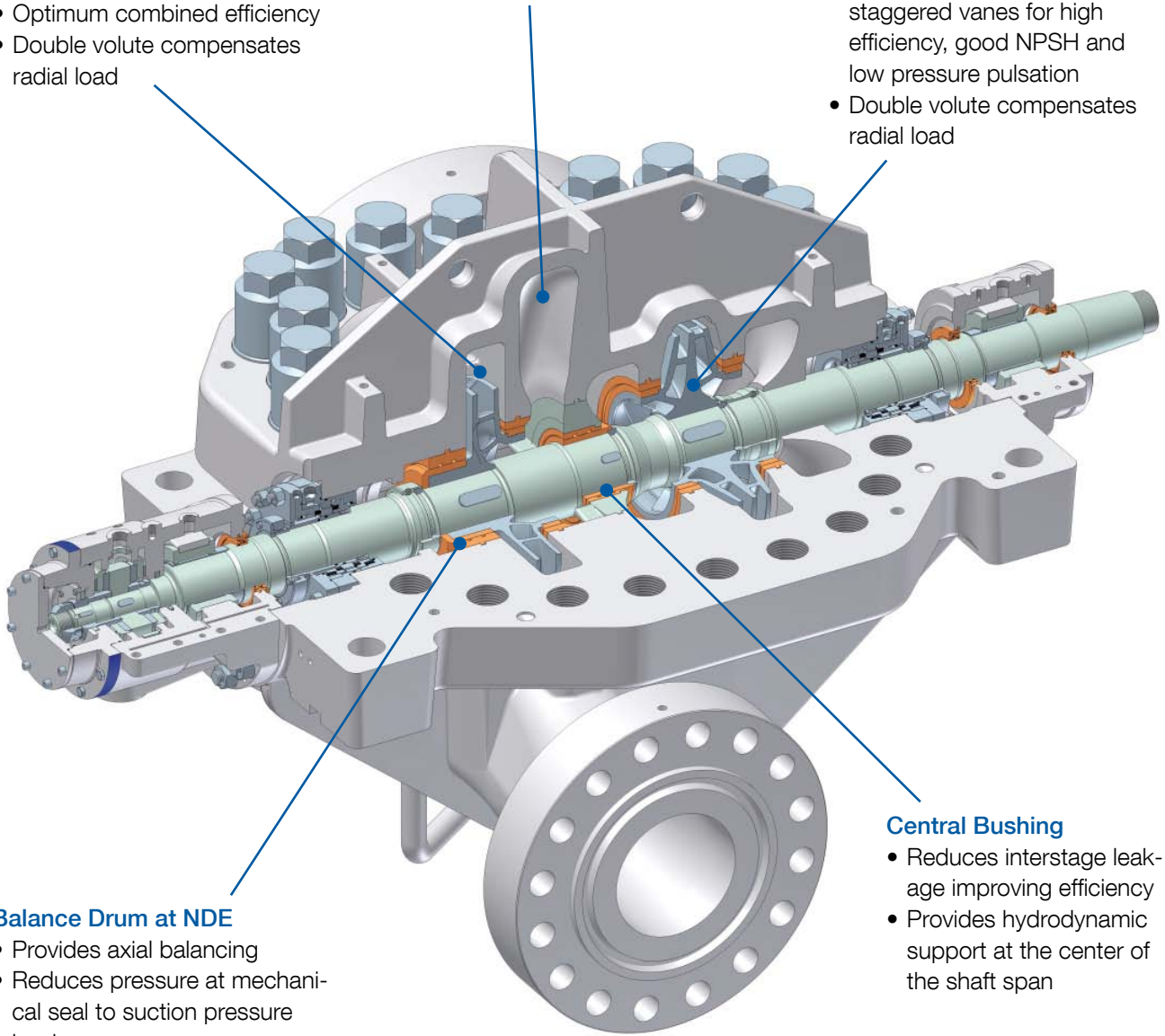

Balance Drum at NDE

- Provides axial balancing
- Reduces pressure at mechanical seal to suction pressure level

Central Bushing

- Reduces interstage leakage improving efficiency
- Provides hydrodynamic support at the center of the shaft span

HPDM Design Features and Benefits

s+s Arrangement

Hydraulics

- Cross-over and cross-under in upper and lower casing allow for efficient flow to second stage

Impellers

- Two single stage impellers, back-to-back for cost effectiveness and efficiency
- First impeller for optimum suction performance
- Wide range of hydraulics for high efficiency
- Back-to-back arrangement compensates axial thrust
- Double volute on each stage compensates radial load

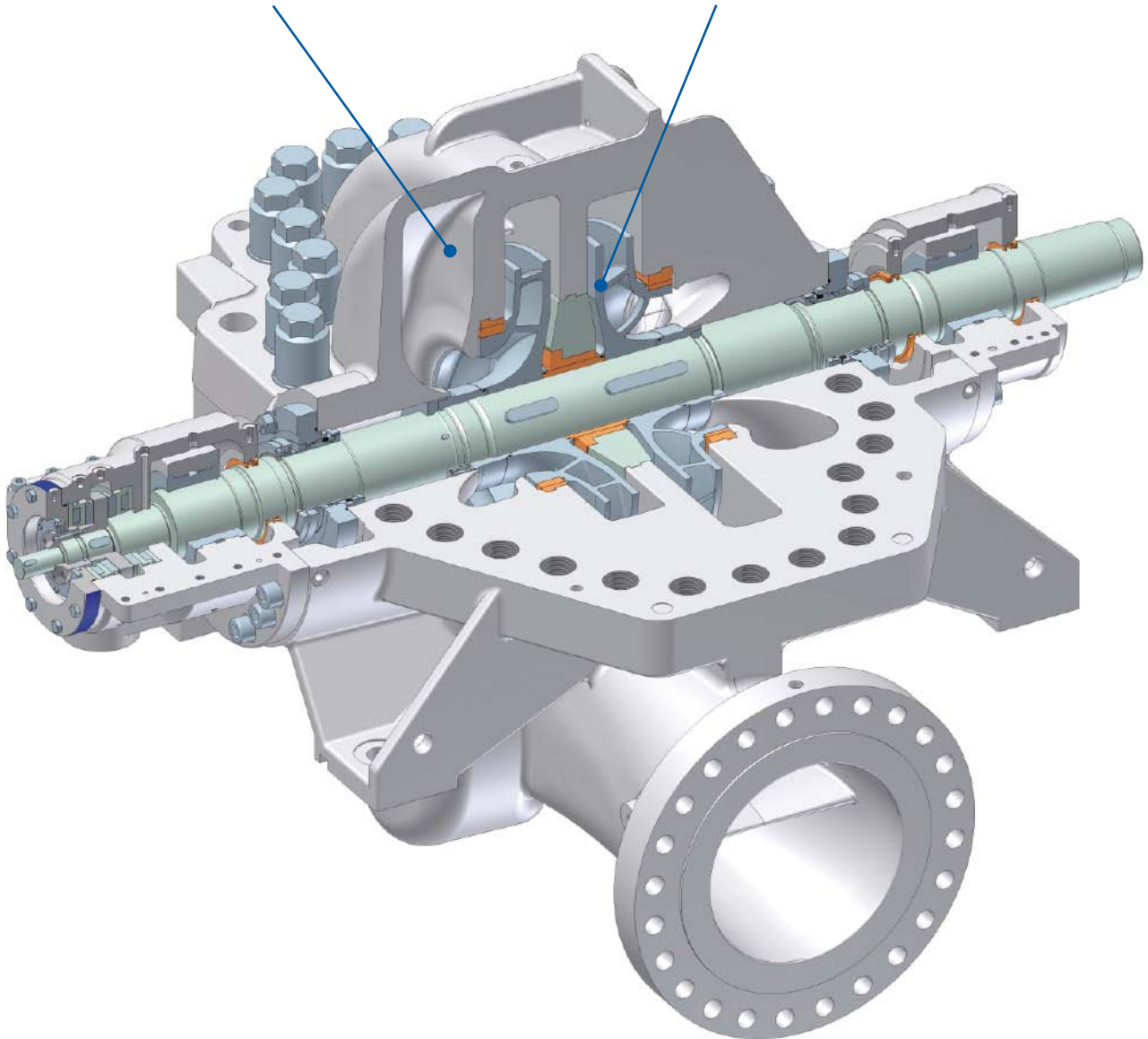

HPDM Design Features and Benefits

1d Arrangement

Impellers

- Double suction impeller allows high efficiency, good NPSH and low pressure pulsation
- Optional staggered vanes are used for high head applications
- Double volute compensates radial loss

Hydraulics

- Wide range of hydraulics available for optimum efficiency

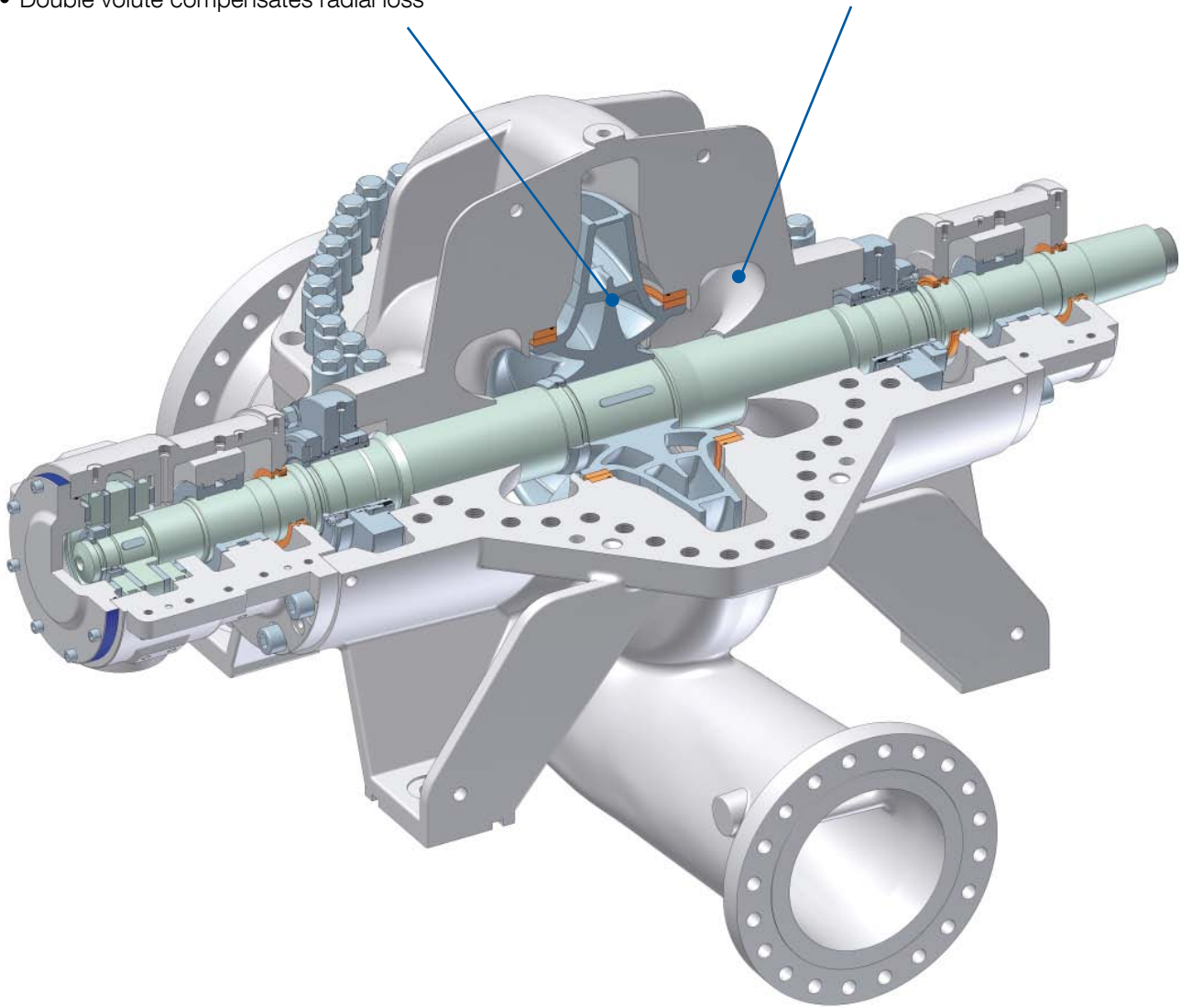

HPDM Performance Range

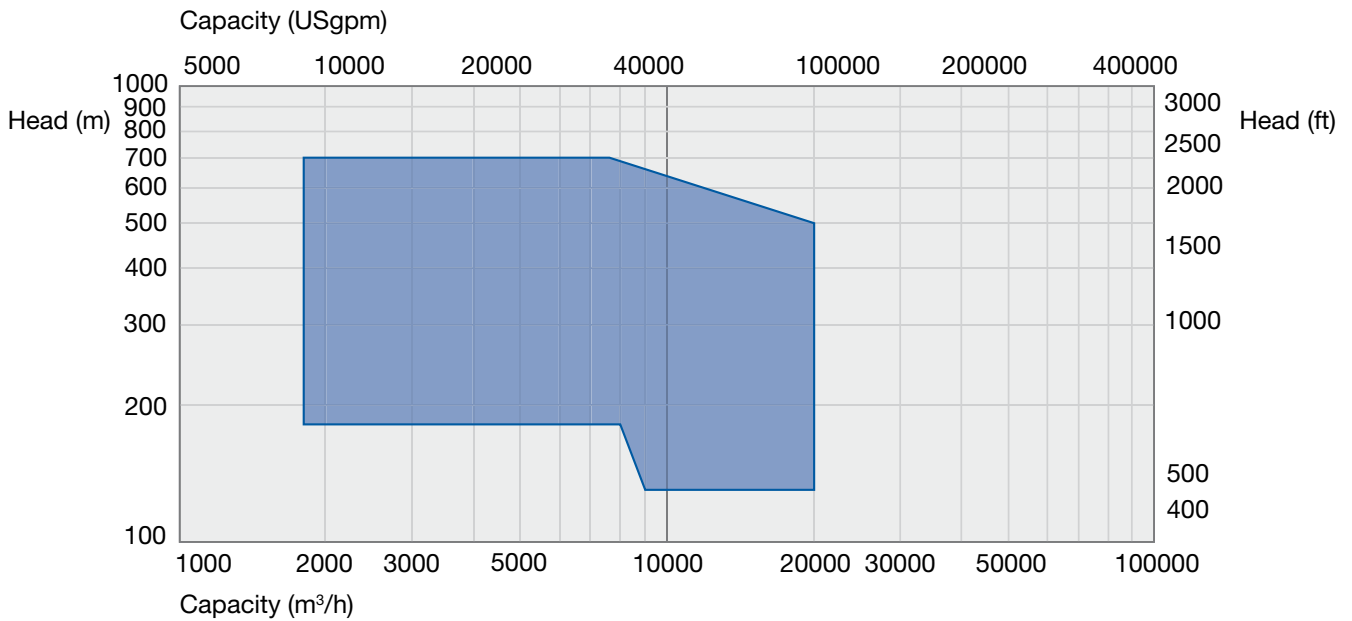

Operating Data

	50 Hz	60 Hz
Pump sizes	250 to 1,600 mm	10 to 64 inches
Capacities	1,000 to 20,000 m³/h	4,400 to 88,000 USgpm
Heads	up to 700 m	up to 2,300 feet
Pressures	up to 175 bar	up to 2,500 psi
Temperatures	up to 70 °C	up to 160 °F

Material Selection

Materials are selected to give high strength as well as high erosion and corrosion resistance under a wide range of liquid qualities and operating conditions. Other material combinations are available to meet customer and application requirements.

Components	Material
Casing	Cast carbon steel, stainless steel, Duplex
Impeller	Chrome steel, stainless steel, Duplex
Shaft	Chrome steel, Duplex
Stationary wear ring	Chrome steel, stainless steel, Duplex

References for Water Industry

Cutzamala Project, Mexico

Project Name	Cutzamala Water Supply System
Location	From Cutzamala River Basin to Mexico City
Length in km (miles)	200 km (124 miles)
Purpose	Provide water for the population and industries of Mexico City and surrounding areas
Product pumped	Raw Water
Pump type	35 HPDM pumps, thereof 23 single stage HPDM 1d and 12 double stage HPDM 2d
Pump stations	6 pump stations
Operating data	Capacities: up to 14,400 m ³ /h (63,300 USgpm) Heads: up to 350 m (1,150 ft)



Al Jubail—Riyadh Project, Saudi Arabia

Project Name	Al Jubail—Riyadh Lines C, D and E
Location	From Al Jubail to Riyadh
Length in km (miles)	3 lines of 480 km each (298 miles)
Purpose	Convey water from desalination plant in Al Jubail to the region of Riyadh for human consumption and industrial uses
Product pumped	Desalinated water
Pump type	58 pumps, thereof 20 single stage SM and HPDM 1d and 38 HPDM s+s
Pump stations	6 pump stations
Operating data	Capacities: up to 15,840 m ³ /h (69,700 USgpm) Heads: up to 509 m (1,700 ft)



References for Oil & Gas Industry

Uthmaniyah Project, Saudi Arabia

Project Name	Uthmaniyah Water Transport Pipeline
Location	From Qurayyah Seawater Treatment Plant to the Uthmaniyah Water Supply Station
Length in km (miles)	98 km (61 miles)
Purpose	Pump treated injection water into the desert to the injection wells of an oilfield
Product pumped	Injection Water
Pump type	2 HPDM 2d pumps
Operating data	Capacities: 10,220 m ³ /h (45,000 USgpm) Heads: 384 m (1,260 ft)

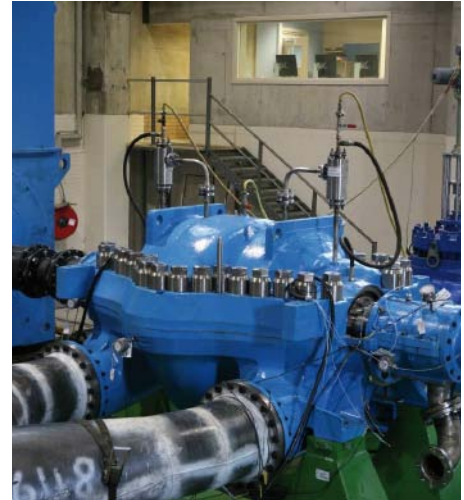

ESPO Project, Russia

Project Name	ESPO Pipeline (East Siberia Pacific Ocean)
Location	From Taishet, Siberia to Chinese border
Length in km (miles)	2,377 km (1,477 miles)
Purpose	Transport oil from Russia to Chinese market
Product pumped	Crude Oil
Pump type	20 HPDM 1d pumps
Operating data	Capacities: 12,000 m ³ /h (52,800 USgpm) Heads: 374 m (1,230 ft)



www.sulzerpumps.com
water.pumps@sulzer.com

E00589 en (1) 2.2011 (1000), Copyright © Sulzer Pumps

This brochure is a general presentation. It does not provide any warranty or guarantee of any kind. Please, contact us for a description of the warranties and guarantees offered with our products. Directions for use and safety will be given separately. All information herein is subject to change without notice.