

Sulzer Pumps MC[®] Discharge Scraper

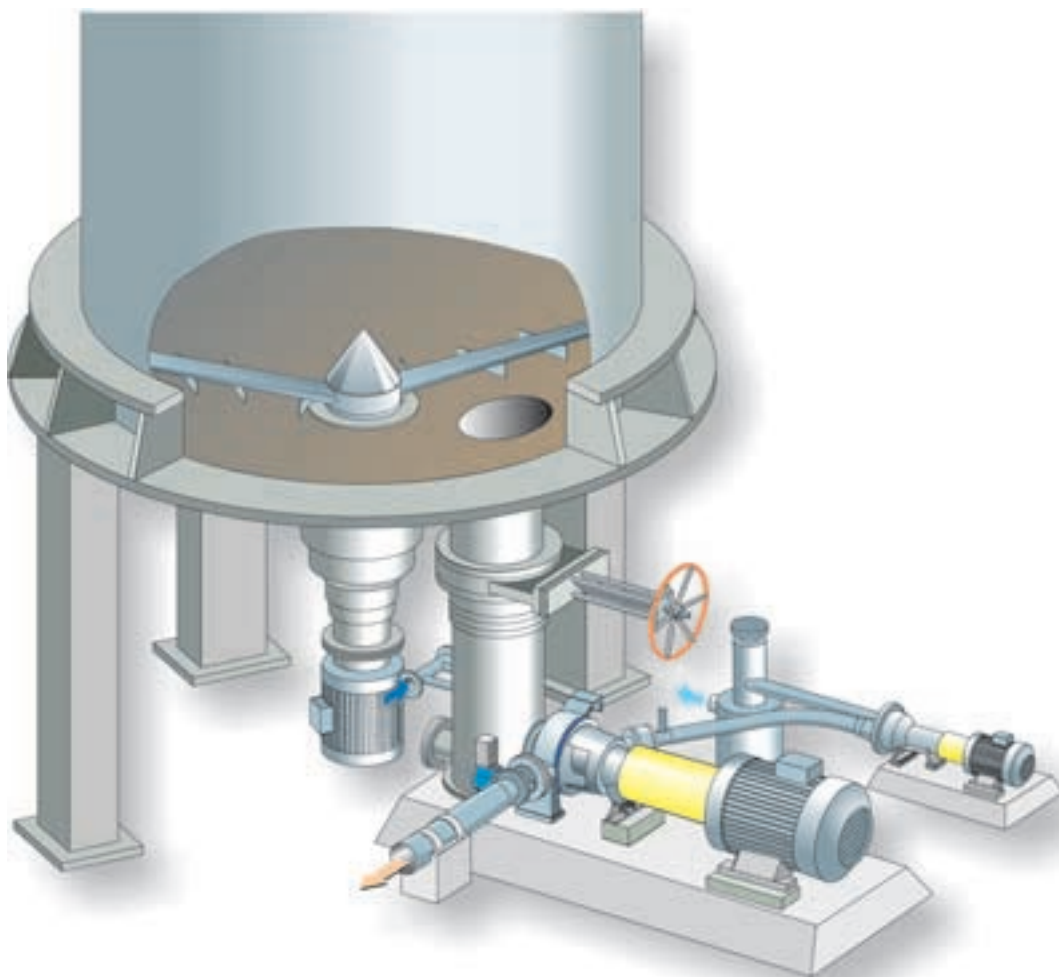

MC[®] Discharge Scraper for Efficient Discharging of High-Consistency Towers

Since 1987, MC[®] Discharge Scrapers have been successfully used for mechanical and chemical pulps in the discharging of high-consistency storage and bleaching towers of various kinds. In most cases it is possible to install a Discharge Scraper in an existing tower with minor changes only.

The discharge of large high-consistency towers often involves difficulties, especially when a well-controlled discharge is required. The Discharge Scraper manufactured by Sulzer Pumps operates in connection with a medium consistency tower discharge MC[®] pump. The Scraper scrapes the stock over the complete bottom area of the tower and leads it into the feed chute of the MC[®] pump, thus enabling an even discharge and simultaneously preventing channelling of the stock in the tower. The Discharge Scraper also stabilizes the pumping procedure.

The Discharge Scraper is manufactured in three different sizes, the diameters being 3000, 4300 and 6500 mm. Each scraper size is available with (MC-xxxx-D) or without (MC-xxxx) a dilution possibility.

The diluting scraper simultaneously dilutes the stock uniformly and discharges the tower without interference. When using diluting scrapers, the consistency of the stock in the tower can be high (20-30%), and the pumping consistency is in the MC[®] range.

The consistency used and the diameter of the tower are factors that contribute to the selection of a scraper. The use of a scraper is recommended in the following cases.

Non-diluting scraper

- diameter of tower >3000 mm
- inlet and outlet consistency 8-13%

Diluting scraper

- diameter of tower >3000 mm
- inlet consistency 13-30%
- outlet consistency max. 13%

Construction

The scraper is fastened to the bottom flange of the stock tower. A flanged electric motor serves as the drive. The bushing of the scraper shaft to the tower is equipped with a water-flushed packing box.

Scraper 3000 with a planetary gear is suspended from the tower bottom. The packings can be replaced without discharging the tower. Scrapers 4300 and 6500 are provided with a spur gear with an upright shaft which is fastened on the slowly rotating secondary shaft of the gear with a fixed coupling. The two-armed scraper equipped with doctor plate is fastened to the scraper shaft.

In the diluting scraper, dilution water is led through the dilution connection along the shaft to the scraper. Dilution water is discharged into the fiber suspension through the holes in the scraper, thus diluting the stock.

Materials

Parts in contact with stock are manufactured of stainless steel SS 2343.



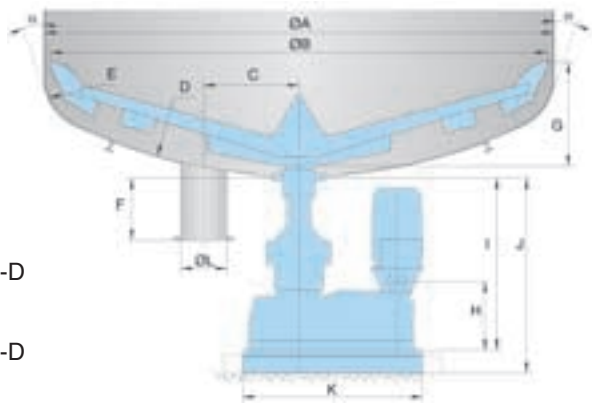

- MC-4300
- MC-4300-D
- MC-6500
- MC-6500-D

*)

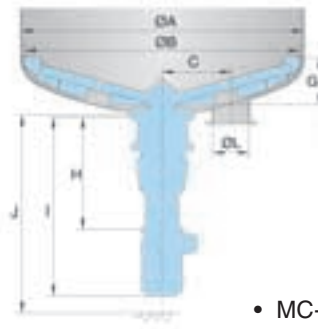

- MC-3000
- MC-3000-D

*)

Main Dimensions, mm

(for preliminary lay-out purposes only; depends on the process and layout data)

Type	A	B	C	D	E	F	G	H	I	J(min)	K	ØL*	α
MC-3000	3100-4300	3000	850-950	3100	310	300	540	1215	1945	2450	-	500/600	-
MC-3000-D	3100	3000	850-950	3100	310	300	540	1215	1945	2450	-	500/600	-
MC-4300	4400-6600	4290	1150-1300	4400	440	590	755	750	2042	2500	2000x1300	500/600/700	20
MC-4300-D	4400	4290	1150-1300	4400	440	590	755	750	2042	2500	2000x1300	500/600/700	-
MC-6500	6700-13000	6510	1250-1400	6700	670	800	1410	905	2250	2700	2360x1400	500/600/700	20
MC-6500-D	6700	6510	1250-1400	6700	670	800	1410	905	2250	2700	2360x1400	500/600/700	-

*) Other sizes also available.

Operational Values

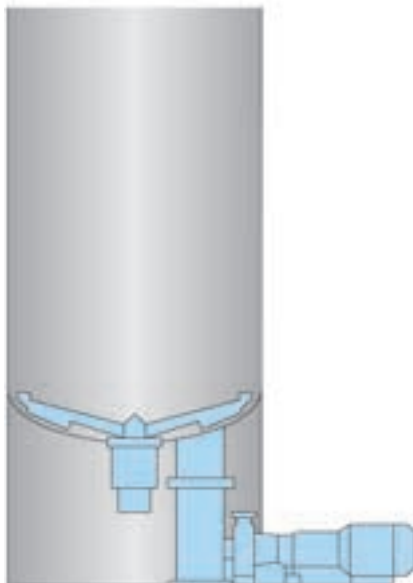

Diameter of scraper, mm	3000	4300	6500
Consistency range, %			
• MC-xxxx	8-13	8-13	8-13
• MC-xxxx-D	13-30	13-30	13-30
Scraper rotating speed, rpm			
• MC-xxxx	10	12	8
• MC-xxxx-D	10	15	8
Power demand max., kW*			
• MC-xxxx	36	88	105
• MC-xxxx-D	36	105	105
Motor			
• MC-xxxx	45/1500	110/1500	132/1500
• MC-xxxx-D	45/1500	132/1500	132/1500
Amount of sealing water, l/min			
• MC-xxxx	3-4	3-4	3-4
• MC-xxxx-D	6-8	6-8	6-8
Pressure of sealing water higher than pressure in tower bottom, bar>			
• MC-xxxx	0.5	0.5	0.5
• MC-xxxx-D	0.5	0.5	0.5
Weight, kg**			
• MC-xxxx	1330	6970	9230
• MC-xxxx-D	1370	6970	9230

* Depends on stock consistency and capacity

** Without motor



Check our worldwide offices at
www.sulzerpumps.com