

**Sulzer Pumps
SALOMIX® SLF Agitator**

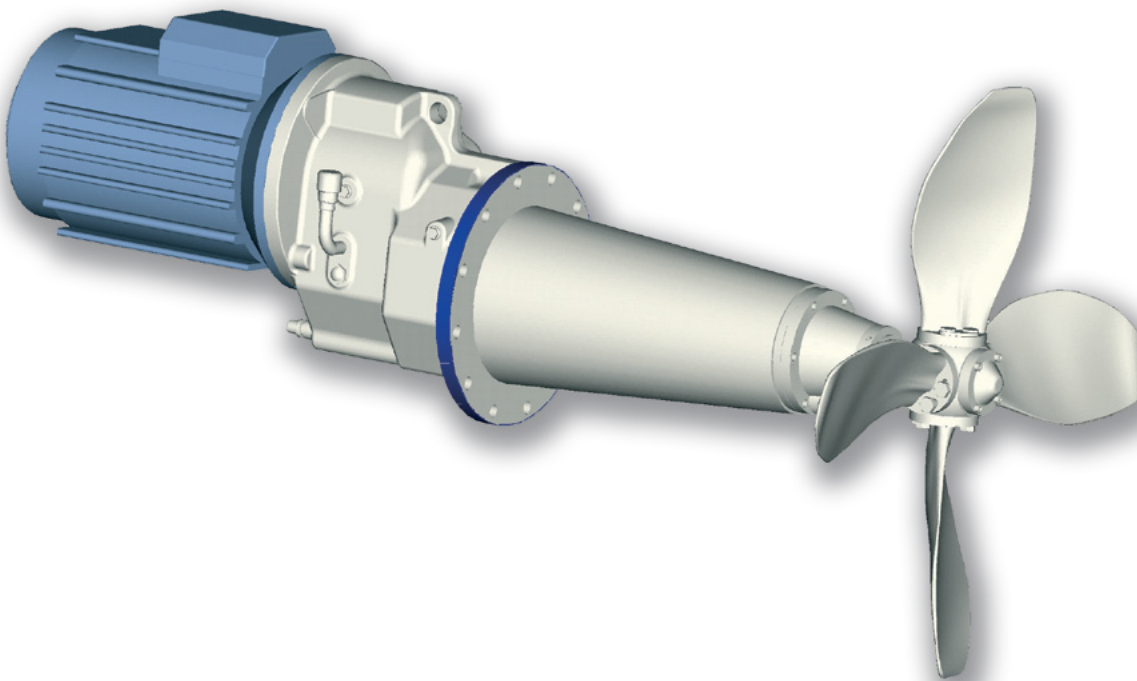

Quality and Performance

Extensive research and development of agitators, precision manufacturing technology with strict quality control according to ISO 9001:2000 assure top efficiency and performance of the SALO-MIX® agitators.

Our traditions in working for the environment has led us to introduce the ISO 14001 standard: the design of the agitators reduces the use of energy and raw materials in the production phase, increases recyclability of the parts and gives long lifetime.

An agitator is always a part of a system involving a tank or a tower with its accessories. Sulzer Pumps has developed many additional devices, such as TES, GLI, VULCA, DILCO, and the special bottom designs of the tower to ensure good runnability of the process, even quality and consistency of the outpumped stock and low total energy consumption of the system.

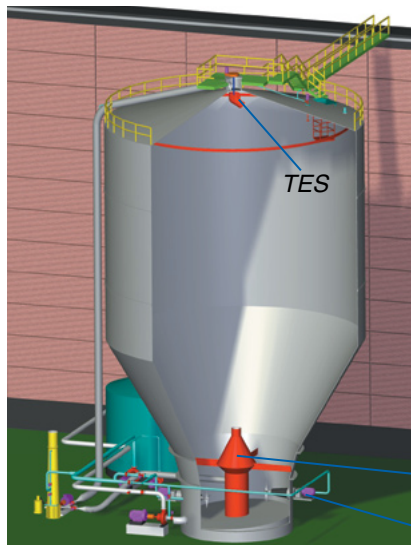

VULCA, GLI

DILCO, Agitator

High Efficiency Chest Agitator with Proven Features for All Purposes

Design

- compact, space saving, no legs
- flange motor

Cone

- long propeller distance from tank wall
- optimum front bearing position, near propeller
- streamlined flow to propeller

Propeller

- adjustable blade angle – controlled energy input
- cast blades – optimized shape to maximize flow

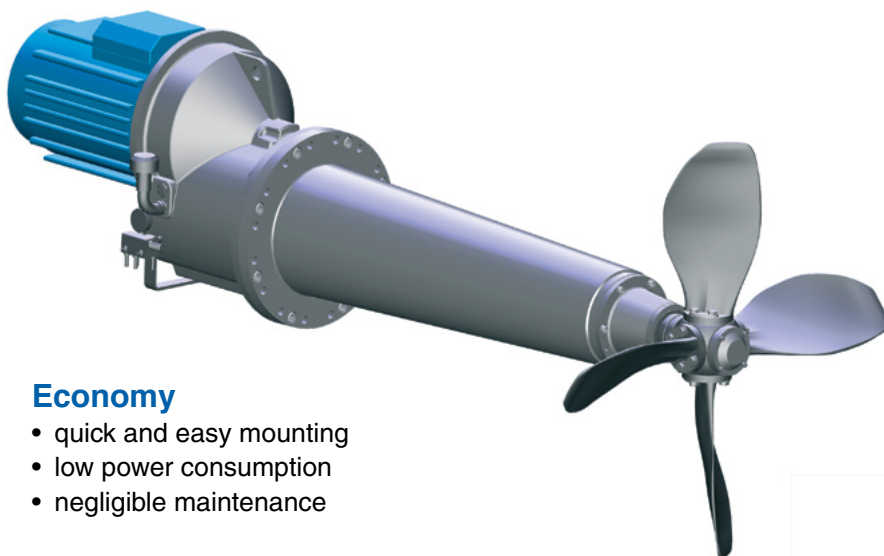

Economy

- quick and easy mounting
- low power consumption
- negligible maintenance

Main Dimensions

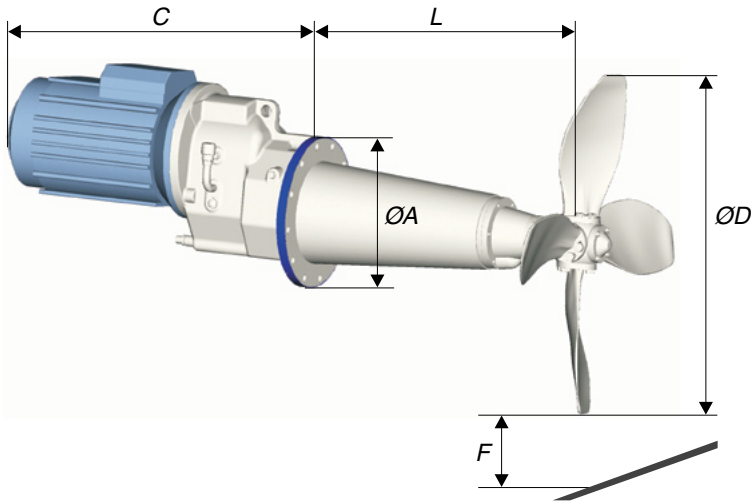

- Installed power range 11 kW - 75 kW
- Propeller diameters 800 mm - 1250 mm

Agitator type	ØA mm	C mm	ØD mm	L* mm	F mm	M** kg
SLF-80.11	440	860	800	850	250	~340
SLF-80.15	440	900	800	850	250	~360
SLF-80.18	440	935	800	850	250	~390
SLF100.18	440	935	1000	850	350	~410
SLF-100.22	440	955	1000	850	350	~430
SLF-100.30	440	1030	1000	850	350	~470
SLF-125.37	565	1300	1250	1300/1600	400	~820
SLF-125.45	565	1300	1250	1300/1600	400	~840
SLF-125.55	565	1300	1250	1300/1600	400	~1040

* Approximate weight includes motor weight.

Mechanical Seal Alternatives

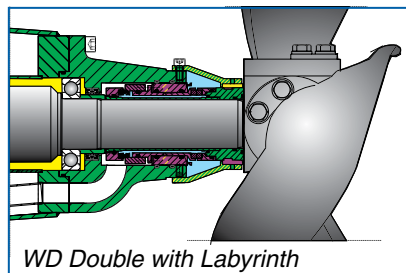
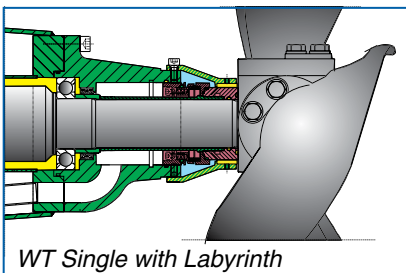
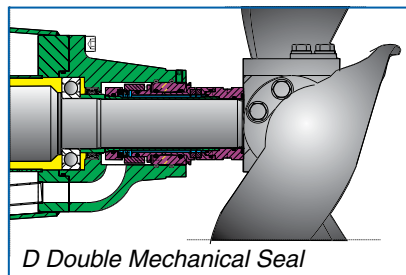
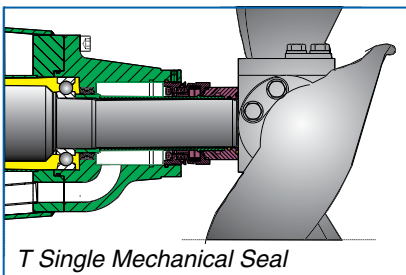

Other options:

- standard wall ring
- big wall ring
- dilution cone DILCO
- bearing control unit
- special cone/propeller materials
- support legs
- grease lubricated seal
- seal water control unit with/without alarm



Check our worldwide offices at
www.sulzerpumps.com