

Minimizing Pressure Pulsations Initiated by the Headbox Feed Pump



The Heart of Your Process

Minimizing Pressure Pulsations Initiated by the Headbox Feed Pump

The main task of the headbox feed pump in a paper machine approach system is to create a uniform flow and pressure to the headbox. Other requirements are good efficiency, reliable design and a smooth inner surface to avoid fiber hang-up.

Paper quality is strongly influenced by the design of the paper machine approach system and the quality of its components. The headbox feed pump is one component in the paper machine approach system which has an effect on the paper quality. Fig. 1 shows a typical paper machine approach system.

Pressure pulsations, initiated by the headbox feed pump, might create unacceptable variations of paper basis weight in the machine direction, Fig. 2.

As there is no centrifugal pump operating without pulsations, it is necessary to reduce the pulsations to a minimum through design and high quality manufacturing.

This article explains the basic principles of pressure pulsations initiated by a centrifugal pump, and how to minimize them. Other possible sources of pressure pulsations are also mentioned as well as special aspects of design and manufacturing of the headbox feed pump.

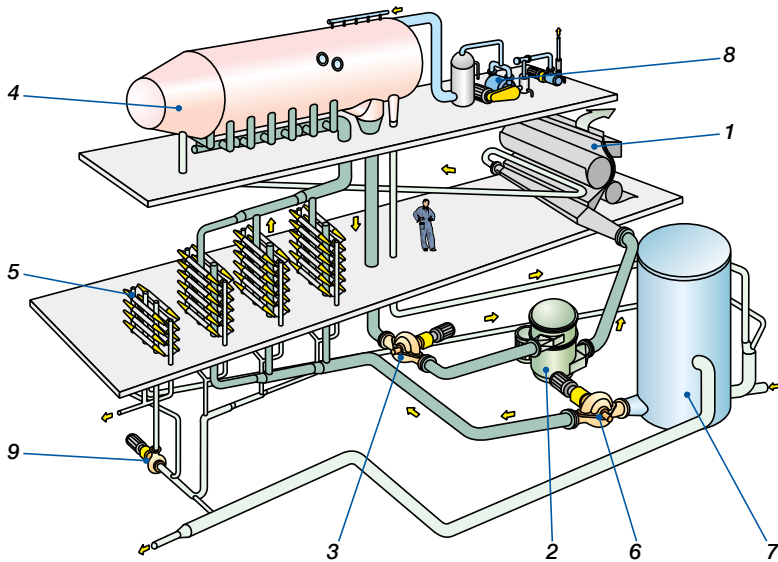

- | | |
|-------------------------|---|
| 1 Headbox | 6 ZPP or AHLSTAR A |
| 2 Headbox screen | 7 White water silo |
| 3 ZPP headbox feed pump | 8 Vacuum pump |
| 4 Deaerator | 9 AHLSTAR A recovery stages cleaner pumps |
| 5 Cleaners | |

Fig. 1. Paper machine approach system

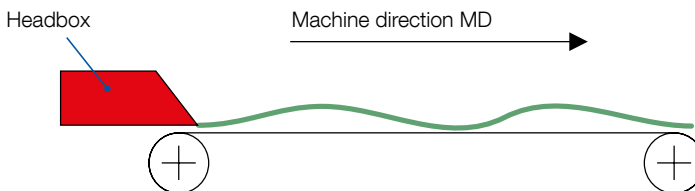

Fig. 2. Variation of basis paper weight MD



Pressure Pulsations in the Paper Machine Approach System

As a paper machine approach system is complex, the sources of pressure pulsations can be initiated, reinforced or dampened by the different components installed in a paper machine approach system.

As there are several factors which can cause pressure pulsations in a paper machine approach system, it is essential to design, manufacture and install all the components, as well as the whole system, in such a way that the pressure pulsations are as low as possible to ensure a trouble-free start-up of the paper machine and to produce a high and constant quality paper.

Sources of Pressure Pulsations in Paper Machine Approach System

Screen

- design and quality of the rotating elements, foils and screen basket

Piping

- design and supports

Mechanical vibration

- pipes which are not well supported
- pumps, screens or other components which are not well fixed to the building
- building itself

Pump drive

- gear box
- coupling
- variable speed control

System design

- overlapping operating frequencies: pump and screen
- resonant frequency pump and system (e.g. pipes)
- control by throttling valve
- control by by-pass

Headbox feed pump

- quality of design and manufacturing, especially of the impeller
- relative position of duty point to BEP (Best Efficiency Point)
- suction condition (NPSH)

Basics of Pressure Pulsations

Frequency

Frequency, Fig. 3, is the number of vibrations in a certain time, e.g. cycles per second, when the unit Hz (Hertz) is used or cycles per minute (cpm).

Amplitude

Amplitude, Fig. 3, in the case of pressure pulsations is the magnitude of the pressure pulsations. The measuring unit for amplitude can be expressed in several ways. Commonly used are: Pa (pascal), mbar (millibar) psi (pounds per square inch) and mWc (meter water column).

Fig. 3 shows graphically and mathematically the relationship between these terms, rms, peak or peak-to-peak.

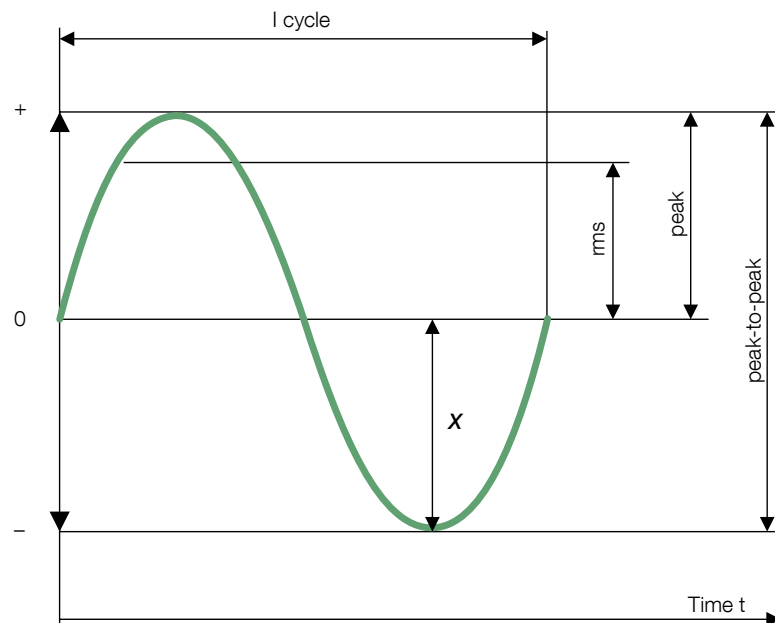

Frequency (f) = Hz (cps)

Amplitude (X), rms, peak, peak-to-peak
= Pa, mbar, mWc, psi

Rms (root-mean-square) = peak/√2

Peak-to-peak = rms x 2√2

1000 Pa=10 mbar = 0.102 mWc=0.15 psi

Fig. 3. Basics of pressure pulsations, frequency and amplitude

Resonance

Resonance is the effect observed when a device sends a certain vibration (pulsation) in a frequency which is the same as the natural frequency of another aggregate or pipe. When the second aggregate receives this vibration it will also start to vibrate.

It is possible that the resonance vibration will have a much bigger magnitude than the initial vibration or pulsation.

Overlapping Frequencies

Overlapping frequencies refer to a situation where two or more components, like the headbox feed pump and the headbox screen, initiate pressure pulsations which are on the same frequency level or very near to each other. The effect of overlapping frequencies is a higher amplitude of the pressure pulsation.

Only periodic pressure pulsations at frequencies which are in harmony with the rotational speed (n) of a pump are caused by the pump.

Pressure Pulsations Initiated by a Centrifugal Pump

Pressure Pulsations at Impeller Vane Frequencies

a) Pressure pulsations at impeller vane frequencies (fz) are initiated by each impeller vane, when passing the volute cutwater, Fig. 4.

The effect is about the same as closing a valve very quickly and thereby causing a pressure shock.

Example:

z = 7 vanes

n = 600 rpm

$f_z = z \times n / 60 = \text{Hz}$

$f_z = 7 \times 600 / 60 = 70 \text{ Hz}$

The distance between the impeller and the volute cutwater affects the amplitude of the pressure pulsation. To obtain a low pressure pulsation, a certain distance between the impeller and the volute cutwater is required. This distance is determined by the hydraulic characteristics of the pump.

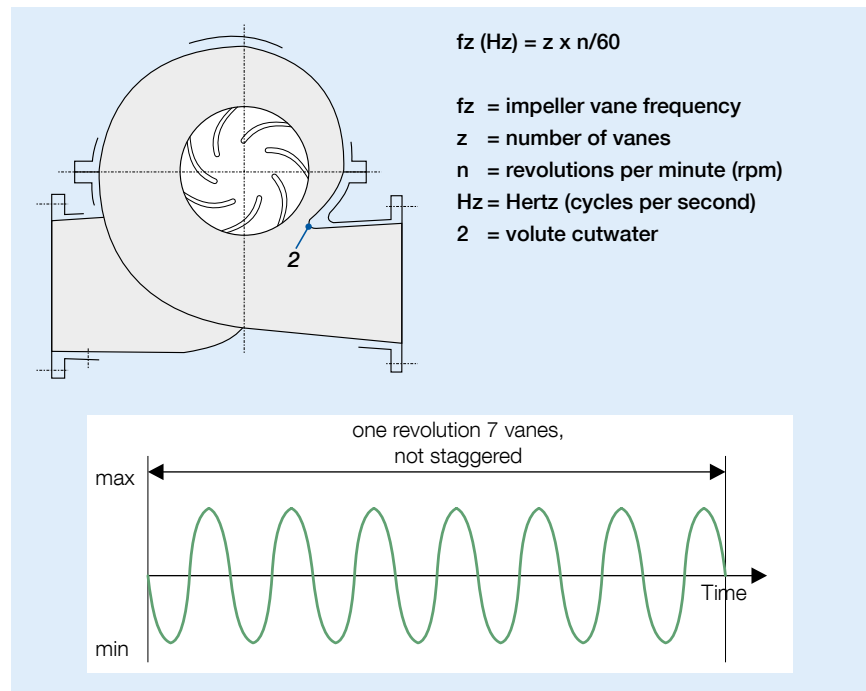

Fig. 4. Pressure pulsations at impeller vane frequencies

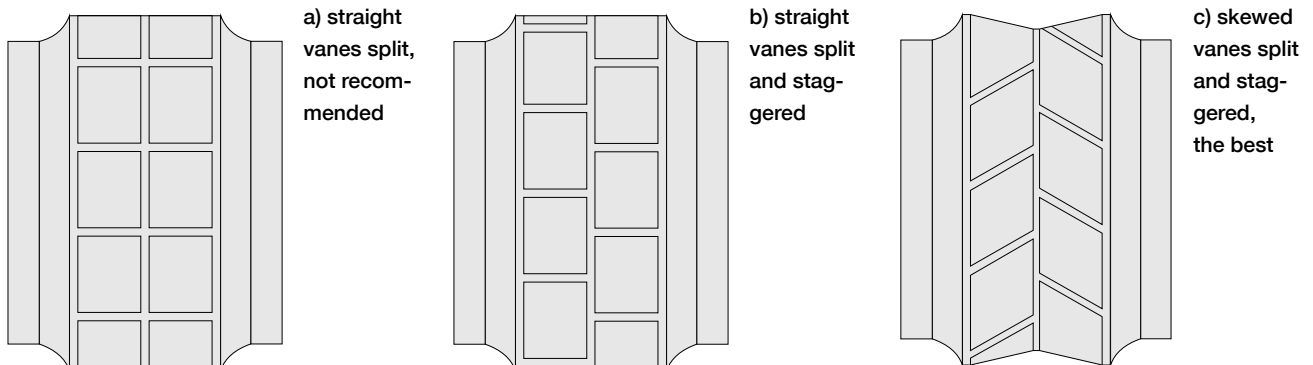

Fig. 5. Impeller vane designs

b) Design of impeller vanes

Fig. 5 shows different designs of impeller vanes. In the case of Fig. 5a, where the tips of the straight, not staggered vanes are passing the volute cutwater with the whole width at once, the magnitude of the pressure pulsation is considerably bigger than in the other case, when the impeller vanes are skewed and staggered, Fig. 5c.

In this case, the width of the vane tips passing the volute cutwater is considerably smaller, and therefore the magnitude of the pressure pulsation is smaller. This effect is even bigger if an impeller with unsplit vanes is used.

Fig. 6 shows the difference of the pressure pulsation Δp in relation to the capacity between straight vanes split, not staggered versus straight vanes split and staggered in a test run. The diagram may only be seen as a tendency showing that one type of impeller causes higher pulsations than another type of impeller.

Pressure Pulsations at Rotational Frequencies

Pressure pulsations at rotational frequencies are initiated by:

- an eccentric contour which means eccentricity of outside diameter, and/or impeller bore and eyes
- an inaccurate surface symmetry which means the lack of perpendicularity and/or a singular irregularity on the impeller surface, Fig. 7.
- an incorrect mechanically balanced rotating unit

Example:

$$n = 1\ 000\ \text{rpm}$$

$$fn = n/60 = \text{Hz}$$

$$fn = 1\ 000/60 = 16.6\ \text{Hz}$$

The result of unacceptable pressure pulsations at rotational frequencies on paper basis weight in MD (Machine Direction) can be seen in Fig. 8.

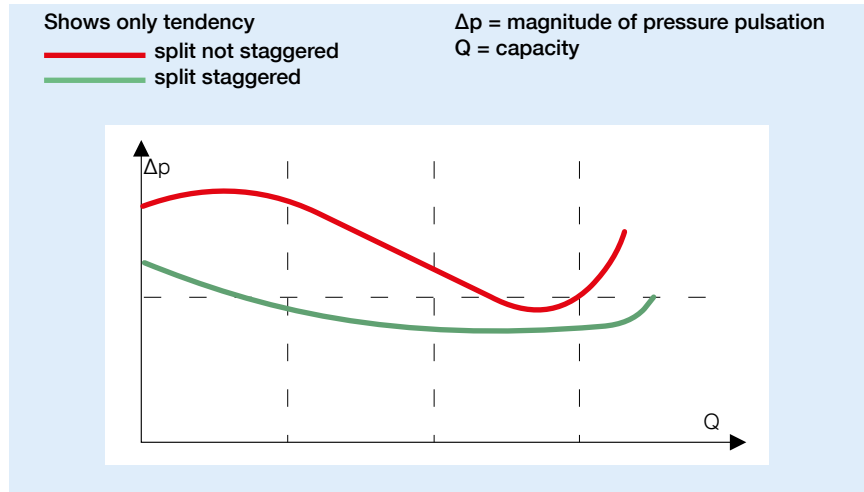

Fig. 6. Effect of impeller vane design on pressure pulsation at different flows

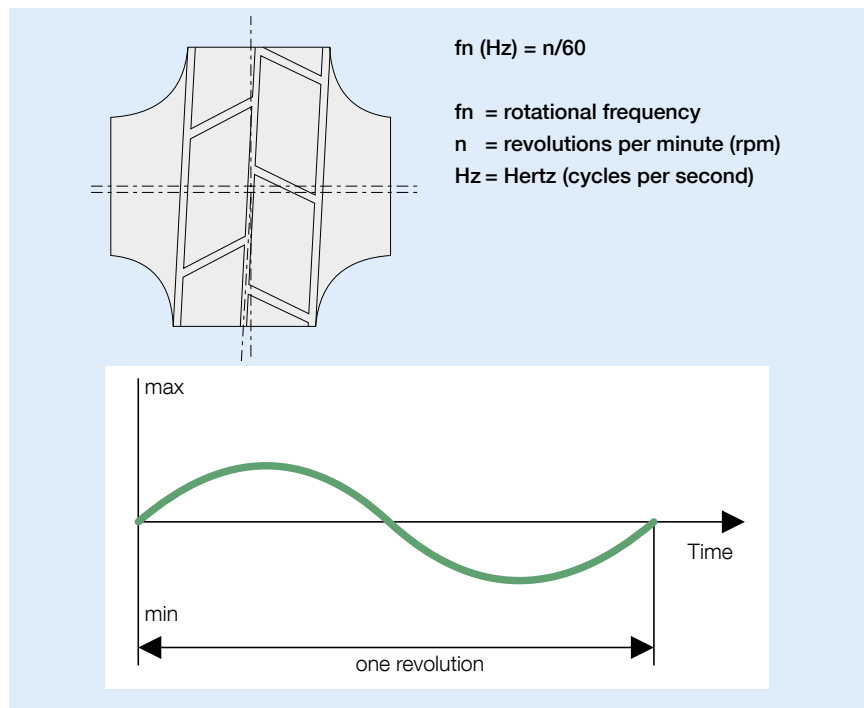

Fig. 7. Pressure pulsations at rotational frequencies

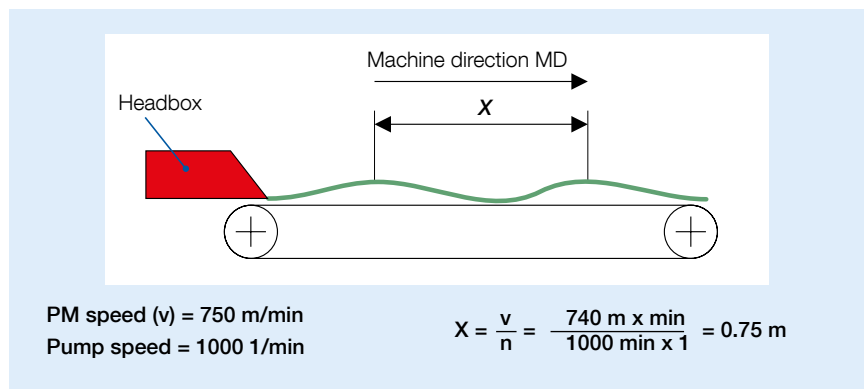

Fig. 8. Variation of paper basis weight in MD at rotational frequencies

Effect of Suction Conditions

If the difference between NPSHa (Net Positive Suction Head), available from the system, and NPSHr, required by the pump, is too small, it may influence the pulsation level. NPSHa must be higher than NPSHr.

Other Aspects of Pressure Pulsations Initiated by a Centrifugal Pump

a) Pressure pulsations, initiated by a centrifugal pump, can be found at several multiples (1 ... x times) of the rotational speed. The highest amplitudes of pressure pulsations are initiated at one and two times of the rotational frequency (fn) and one and two times of the vane frequency (fz).

Pressure pulsations at two times rotational frequency (fn) can originate from misalignment between drive and pump. They can also occur, if there is a clearance in the coupling, or if a flexible coupling or an incorrectly assembled universal shaft is used.

b) Pressure pulsation level is influenced by the position of the duty point to BEP (Best Efficiency Point). Fig. 9 shows that the lowest pulsation is reached, if the duty point is near to BEP and to the left of it.

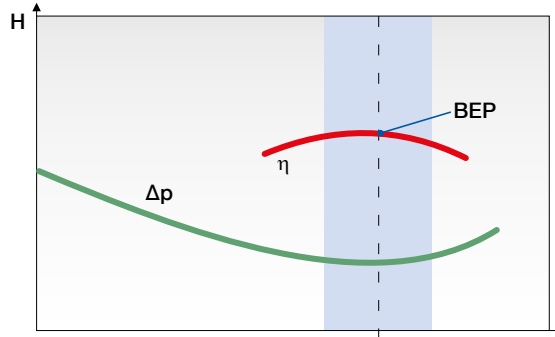

Fig. 9. Effect of position of duty point on pressure pulsation

Impeller Design and Quality

As the impeller design and manufacturing quality are by far the most important factors in respect of pressure pulsations, special attention must be paid to them.

Fig. 10 shows the most important design details and manufacturing steps which are necessary to obtain a high-precision impeller initiating only low-pressure pulsations.

- 1 High precision castings
- 2 Impeller vanes staggered and skewed
- 3 Equal vane passage volume
- 4 High degree of concentricity of inlet and outlet vane edges, equal vane angles
- 5 High degree of impeller contour concentricity and surface symmetry
- 6 Dynamically balanced rotating unit
- 7 Strict manufacturing quality control

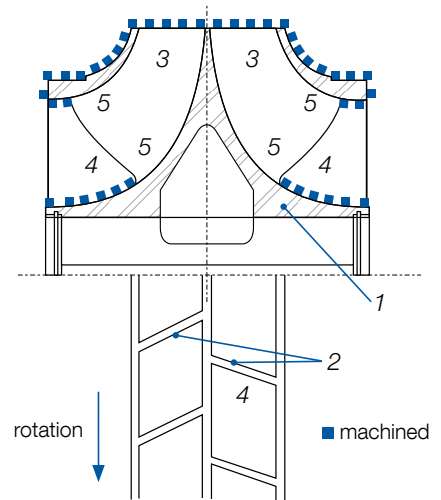

Fig. 10. Design and manufacturing quality of the impeller

Designation	ZPP31-400
Job no.	300187
Serial no.	92300187
Test date	Dec 14, 2006
Test speed 1/min	1050 rpm
Pulsation at rotational frequency	
mbar	± 1.75
mm water column	± 17.8

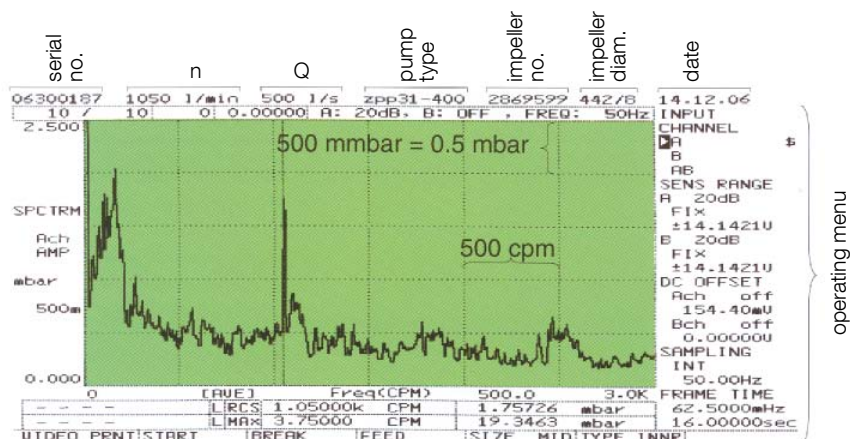

Fig. 11. Pulsation test report

Minimizing Pressure Pulsations

When minimizing pressure pulsation of centrifugal pump in headbox feed application following aspects need to be taken into consideration.

Pressure Pulsations at Impeller Vane Frequencies

Pressure pulsations at impeller vane frequencies (f_z) are:

- reduced by the design and manufacturing quality of the impeller
- reduced by using an impeller with staggered, split and skewed vanes
- reduced by maintaining a certain distance between the impeller and the volute cutwater
- dampened by friction resistance of pipes and other components in the paper machine approach system

Based on field experience, the frequencies of pressure pulsations at impeller vane frequencies are in most cases above 60 Hz, and as they are dampened by the system, their effects on the paper quality in general are not harmful. It is therefore an advantage to use a pump with higher speed, because the higher the frequencies of the pressure pulsations the more effectively they are dampened.

Pressure Pulsations at Rotational Frequencies

Pressure pulsations at rotational frequencies (f_n) are:

- reduced by the design and manufacturing quality of the impeller
- reduced by balancing the rotating unit dynamically
- lowest if the duty point is near to BEP (Best Efficiency Point)
- lowest at 2 x rotational frequency (f_n) if a gear type coupling is used

Other Aspects

a) Overlapping operating frequencies; pump and screen. As the screen, which is placed between the headbox feed pump and headbox, also initiates pressure pulsations, its frequencies should not be near or at the pump frequencies. Otherwise the pressure pulsations initiated by the headbox feed pump can be reinforced by the pressure pulsations initiated by the screen.

b) As variable speed drive is frequently used for new headbox feed pumps, the speed of the motor should not vary.

c) There are attenuators available on the market. But first of all, when planning a paper machine approach system, attention should be paid to build and install only components which assure low pressure pulsations without any adverse effects on the paper quality.

Testing of Pressure Pulsations

Pressure pulsation tests can be carried out at the test station in the factory. An example of a pulsation test report is shown in Fig. 11. The graphic presents the pressure pulsations amplitude versus frequency.

The vertical scale for the amplitude is divided into 500 mbar (0.5 mbar) between the dotted lines. The total length is 2.500 mbar. The values are expressed in rms. The horizontal scale for the frequency is divided into 500 cpm (cycles per minute) between the dotted lines. The total length is 3000 cpm (50 Hz).

The pressure pulsation at rotational speed is 1.75 mbar, in this example. These scales can be changed e.g. the frequency band up to 200 Hz or higher. Other explanation of the graphic, see Fig. 11.

Summary

With the total of worldwide almost 4000 installed headbox feed pumps and 1st stage cleaner pumps, Sulzer Pumps has an outstanding high number of references for different applications in respect of papergrade or paper machine supplier.

This, together with our basic research, modern designing methods and manufacturing facilities, enables us to supply these pumps according to the high demands of today's fast and modern paper machines producing paper in high quality.

www.sulzerpumps.com
ppi-info.pumps@sulzer.com



E00531 en (4) 10.2011 (500), Copyright © Sulzer Pumps
This brochure is a general product presentation. It does not provide a warranty or guarantee of any kind. Please, contact us for a description of the warranties and guarantees offered with our products. Directions for use and safety will be given separately. All information herein is subject to change without notice.