

SULZER



Sulzer Pumps Vertical Pumps

The **Heart**
of Your
Process



Vertical Pumps

B Series

Sulzer supplies a wide range of hydraulic designs to suit most vertical line shaft pump applications. The BK, BS and BP range of vertical line shaft pumps are primarily used in water lift, transfer and cooling water applications. A double suction variant, the BD, is available where NPSH is limited.



Features

- Simple start-up without venting beforehand
- Great reliability and long maintenance intervals
- Outstanding adaptability to fluctuating water levels
- Numerous installation possibilities with parts manufactured according to the standardized component system
- Operating speed lower than the first critical shaft speed



BK / BK_n

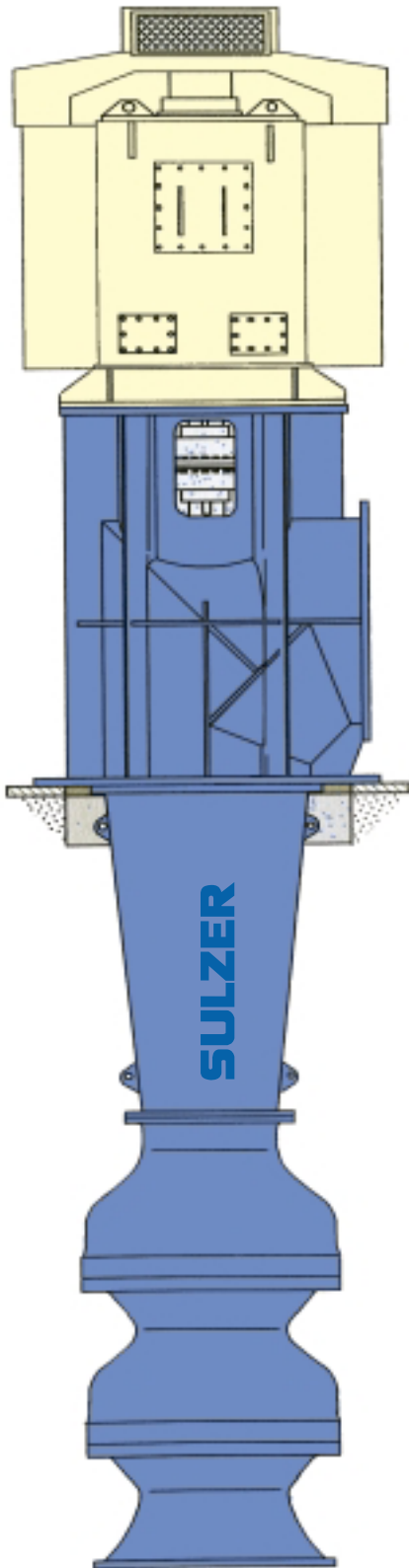

Performance Range

The overall performance range provides for discharge rates of 150 to 50'000 m³/h (660 U.S. gpm to 220'100 U.S. gpm) and delivery heads of up to 285 m for the BK range and 80 m for the BK_n range.

Pressure Range

The pumps are designed for pressures up to 40 bar.

Temperature Range

The pumps are suitable for temperatures ranging from - 40°C to + 85°C.

Principal Fields of Application

- Water supply systems
- Water treatment plants
- River and sea water intakes
- Pressure boosting stations
- Cooling pumps in thermal power stations.
- Lowering the ground water level
- Sea water desalination plants
- Petrochemical installations

Design

The vertical pumps, type BK/BK_n, are single or multi-stage, semi-axial pumps and manufactured according to the unit construction principle. With just a few modifications, it is possible to adapt the pumps so that they comply with API 610 requirements.

The pump is constructed using the following units.

Pumping Element

The pump itself consists of single or multi-stage, bolt-connected stages, i.e. the casing elements with the overflow channels, the semi-axial closed impellers and the pump shaft, which is seated in radial bearings.

Rising column and driving shaft

Depending on requirements, the riser consists of one or more elements of cast or welded design. In accordance with its length, the driving shaft, is seated in one or more support bearings.

Performance Range

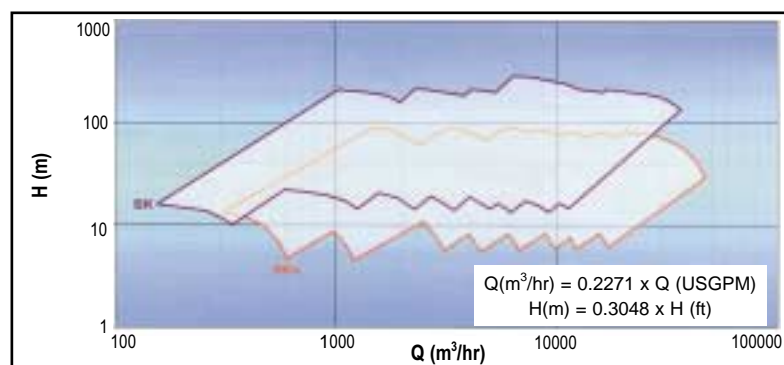

BK / BK_n

Motor Pedestal

Depending on the conditions and customer requirements, this is designed with or without axial bearings.

Drive

Direct or remote coupled vertical electric motors are usually fitted.

Gear units are available, should the pump speed be too low for an economical motor selection.

Diesel drive with right angle gear boxes is an alternative. If required, hydraulic motors with any type of prime mover can be employed.

Shaft Seal

The shaft seal is effected by means of normal stuffing box packing or a mechanical seal. Where necessary, a balancing bush for the pressure or a seal-cooling arrangement is fitted.

Bearings and Lubrication

The **axial thrust** of the pump is taken up by anti-friction or plain bearings. The respective bearing is fitted in the motor pedestal or directly in the motor itself. If necessary, air or water cooling can be provided.

The pump and driving shaft is seated in radial bearings, and lubricated by the medium being handled or by means of an external lubricant supply (fresh water, grease or oil).

Critical Speed

The first critical natural frequency of the driving shaft is higher than the pump speed. The rising column pipe is dimensioned in

such a way that its natural frequency is not in a whole-number ratio to the pump speed.

Inlet and Outlet Branches

The pumps can be supplied for dry-pit and wet-pit installation, with horizontal outlet branch arranged above or below ground level. When installed with a suction tank, the inlet branch is arranged above or below ground level, and the outlet branch horizontally above ground level.

Connecting Flanges

In accordance with the respective standard requirements.



BK / BK_n

Design Features

Material options for a wide range of applications

Wetted parts in cast iron, chromium steel, stainless steel, duplex stainless steel. Special combinations available on request.

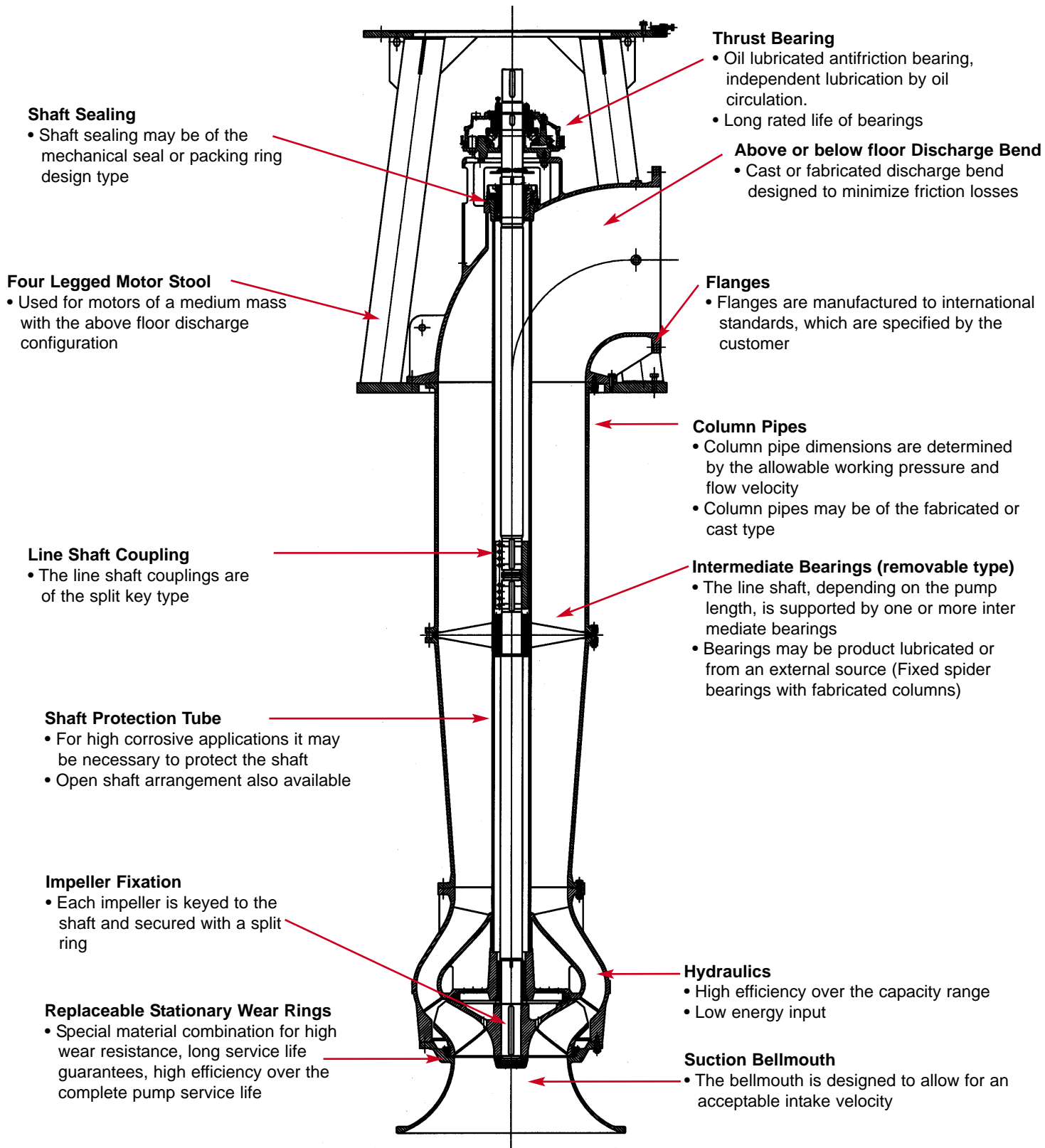

BS / BSn / BSm

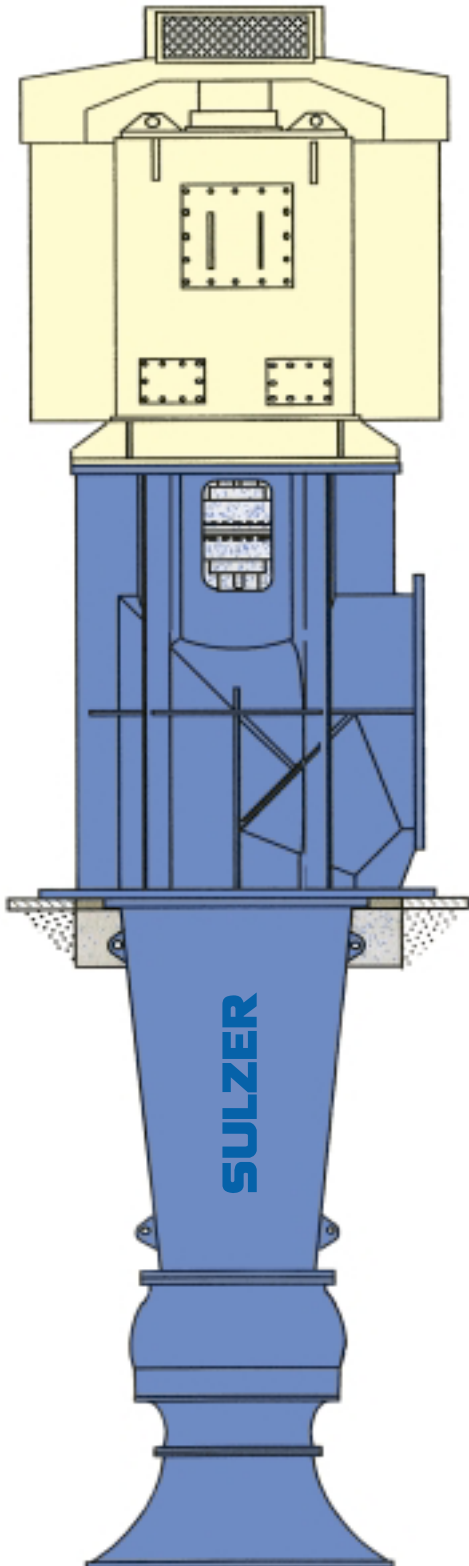

Performance Range

The overall performance range provides for discharge rates of 500 to 70'000 m³/h (2200 U.S. gpm to 308'200 U.S. gpm) and delivery heads of 4 up to 20 m (in 2 stage design up to 40 m).

Pressure Range

The pumps are designed for pressures up to 10 bar.

Temperature Range

The pumps are suitable for temperatures ranging from – 40°C to + 85°C.

Principal Fields of Application

- Water supply systems
- Water treatment plants
- River and sea water intakes
- Cooling pumps in thermal power stations.
- Sea water desalination plants
- Irrigation and drainage schemes
- Booster pumps in storage plants
- Dock impounding duties
- Petrochemical installations

Design

The vertical pumps, type BS/BSn/BSm, are normally single stage semi-axial pumps and manufactured according to the unit construction principle. With just a few modifications, it is possible to adapt the pumps so that they comply with API 610 requirements.

The pump is constructed using the following units.

Pumping Element

The pump itself consists of the casing segment, the impeller shroud, the semi-axial impeller and the pump shaft, which is seated in a radial bearing.

Rising column and driving shaft

Depending on requirements, the riser consists of one or more elements of cast or welded design. In accordance with its length, the driving shaft, is seated in one or more support bearings.

Performance Range

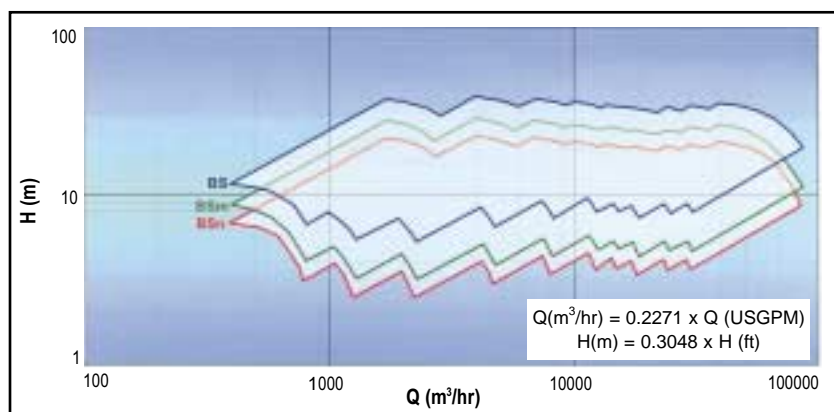

BS / BSn / BSm

Motor Pedestal

Depending on the conditions and customer requirements, this is designed with or without axial bearings.

Drive

Direct or remote coupled vertical electric motors are usually fitted.

Gear units are available, should the pump speed be too low for an economical motor selection.

Diesel drive with right angle gear boxes is an alternative. If required, hydraulic motors with any type of prime mover can be employed.

Shaft Seal

The shaft seal is effected by means of normal stuffing box packing or a mechanical seal. Where necessary, a balancing bush for the pressure or a seal-cooling arrangement is fitted.

Bearings and Lubrication

The **axial thrust** of the pump is taken up by anti-friction or plain bearings. The respective bearing is fitted in the motor pedestal or directly in the motor itself. If necessary, air or water cooling can be provided.

The pump and driving shaft is seated in radial bearings, and lubricated by the medium being handled or by means of an external lubricant supply (fresh water, grease or oil).

Critical Speed

The first critical natural frequency of the driving shaft is higher than the pump speed. The rising column is dimensioned in such a

way that its natural frequency does not stand in a whole-number ratio to the pump speed.

Inlet and Outlet Branches

The pumps can be supplied for dry-pit and wet-pit installation, with horizontal outlet branch arranged above or below ground level. When installed with a suction tank, the inlet branch is arranged above or below ground level, and the outlet branch horizontally above ground level.

Connection Flanges

In accordance with the respective standard requirements.



BS / BSn / BSm

Design Features

Material options for a wide range of applications

Wetted parts in cast iron, chromium steel, stainless steel, duplex stainless steel. Special combinations available on request.

Thrust Bearing

- Oil lubricated antifriction bearing
- Safe rotation, independent lubrication by oil circulation
- Long rated life of bearings

Shaft Sealing

- Shaft sealing may be of the mechanical seal or packing ring design type

Line Shaft Coupling

- The line shaft couplings are of the split key type

Column Pipes

- Column pipe dimensions are determined by the allowable working pressure and flow velocity
- Column pipes may be of the fabricated or cast type

Impeller Fixation

- Each impeller is keyed to the shaft and secured with a split ring

Fabricated Combined Discharge Bend Motor Stool

- Used for motors of a low mass with the above floor discharge configuration

Above Floor Discharge Bend

- Fabricated discharge bend designed to reduce losses and pump mass to the minimum

Flanges

- Flanges are manufactured to international standards, which are specified by the customer

Intermediate Bearings (fixed type)

- The line shaft, depending on the pump length, is supported by one or more intermediate bearings
- Bearings may be product lubricated or from an external source

Hydraulics

- High efficiency over the capacity range
- Low energy input

Suction Bellmouth

- The bellmouth is designed to allow for an acceptable intake velocity

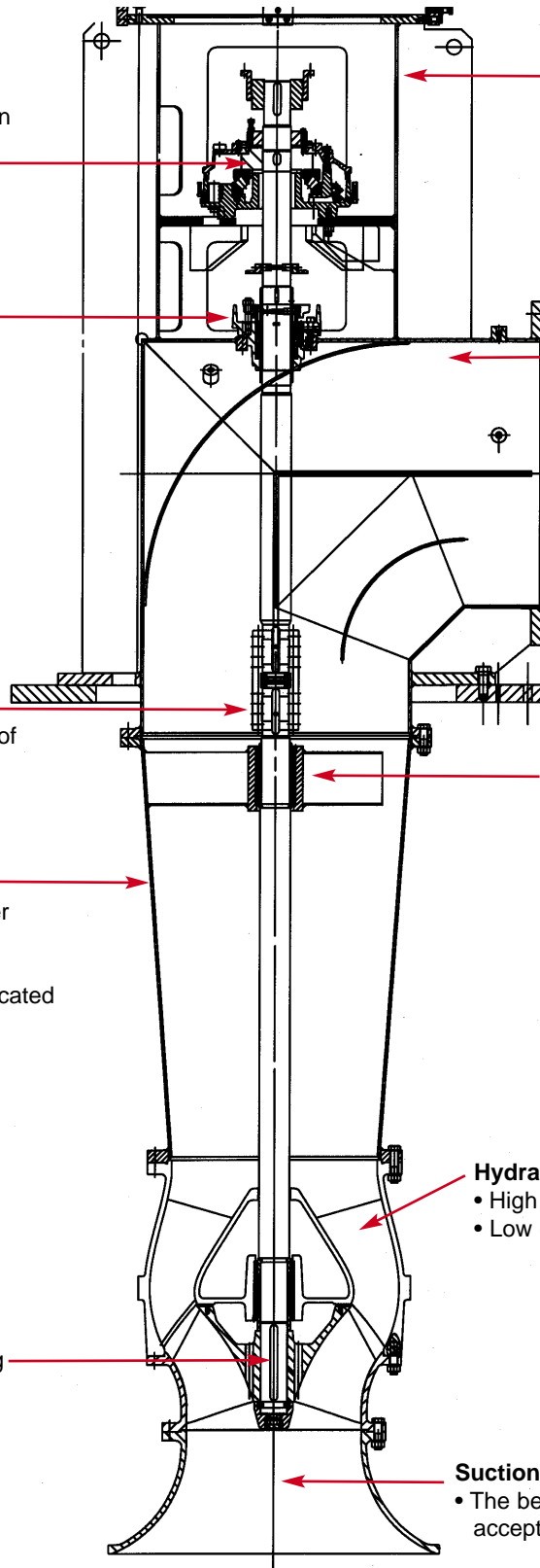

BPn

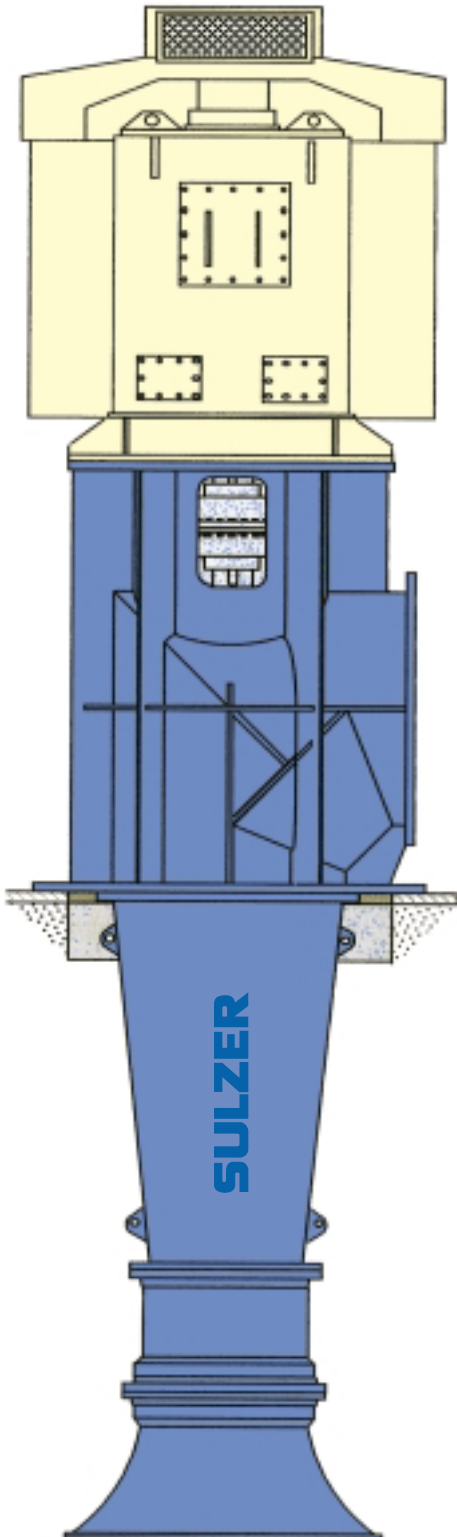

Performance Range

The overall performance range provides for discharge rates of 350 to 40'000 m³/h (1540 U.S. gpm to 176 130 U.S. gpm) and delivery heads of up to 8 m (for the BPn range).

Pressure Range

The pumps are designed for pressures up to 10 bar.

Temperature Range

The pumps are suitable for temperatures ranging from – 40°C to + 85°C.

Principal Fields of Application

- Water supply systems
- Water treatment plants
- River and sea water intakes
- Cooling pumps in thermal power stations.
- Sea water desalination plants
- Petrochemical installations
- Irrigation and drainage schemes, in fact wherever large volumes of water have to be handled against low heads.

Design

The BPn vertical pump type is a single stage pump and manufactured according to the unit construction principle. With just a few modifications, it is possible to adapt the pumps so that they comply with API 610 requirements.

The pump is constructed using the following units.

Pumping Element

The pump itself consists of the suction flare, the tapered rising pipe, the impeller and the pump shaft, which is seated in a radial bearing. The impeller has fixed blades which can be adjusted at standstill.

Rising column and driving shaft

Depending on requirements, the riser consists of one or more elements of cast or welded design. In accordance with its length, the driving shaft, is seated in one or more support bearings.

Performance Range

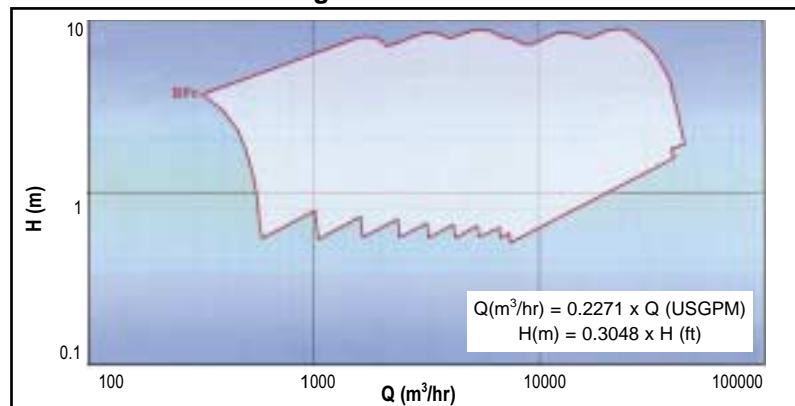

BPn

Motor Pedestal

Depending on the conditions and customer requirements, this is designed with or without axial bearings.

Drive

Direct or remote coupled vertical electric motors are usually fitted.

Gear units are available, should the pump speed be too low for an economical motor selection.

Diesel drive with right angle gear boxes is an alternative. If required, hydraulic motors with any type of prime mover can be employed.

Shaft Seal

The shaft seal is effected by means of normal stuffing box packing or a mechanical seal. Where necessary, a balancing bush for the pressure or a seal-cooling arrangement is fitted.

Bearings and Lubrication

The **axial thrust** of the pump is taken up by anti-friction or plain bearings. The respective bearing is fitted in the motor pedestal or directly in the motor itself. If necessary, air or water cooling can be provided.

The pump and driving shaft is seated in radial bearings, and lubricated by the medium being handled or by means of an external lubricant supply (fresh water, grease or oil).

Critical Speed

The first critical natural frequency of the driving shaft is higher than the pump speed. The rising

column is dimensioned in such a way that its natural frequency does not stand in a whole-number ratio to the pump speed.

Inlet and Outlet Branches

The pumps can be supplied for dry-pit and wet-pit installation, with horizontal outlet branch arranged above or below ground level. When installed with a suction tank, the inlet branch is arranged above or below ground level, and the outlet branch horizontally above ground level.

Connecting Flanges

In accordance with the respective standard requirements.



BPn

Design Features

Material options for a wide range of applications

Wetted parts in cast iron, chromium steel, stainless steel, duplex stainless steel. Special combinations available on request.

Motor Mounting (two floor option)

Heavy motors, gearboxes are mounted on a second floor above the pump arrangement (close coupled option is also available)

Shaft Sealing

- Shaft sealing may be of the mechanical seal or packing ring design type

Line Shaft Coupling

- The line shaft couplings are of the split key type

Column Pipes

- Column pipe dimensions are determined by the allowable working pressure and flow velocity
- Column pipes may be of the fabricated or cast type

Impeller Fixation

- Each impeller is keyed to the shaft and secured with a split ring

Replaceable Stationary Wear Rings

- Special material combination for high wear resistance, long service life guarantees, high efficiency over the complete pump service life

Thrust Bearing

- Oil lubricated antifriction bearing, independent lubrication by oil circulation.
- Long rated life of bearings

Above or Below Floor Discharge Bend

- Fabricated discharge bend designed to minimize losses and pump mass to the minimum

Flanges

- Flanges are manufactured to international standards, which are specified by the customer

Intermediate Bearings (fixed type)

- The line shaft, depending on the pump length, is supported by one or more intermediate bearings
- Bearings may be product lubricated or from an external source

Hydraulics

- High efficiency over the capacity range
- Low energy input

Suction Bellmouth

- The bellmouth is designed to allow for an acceptable intake velocity

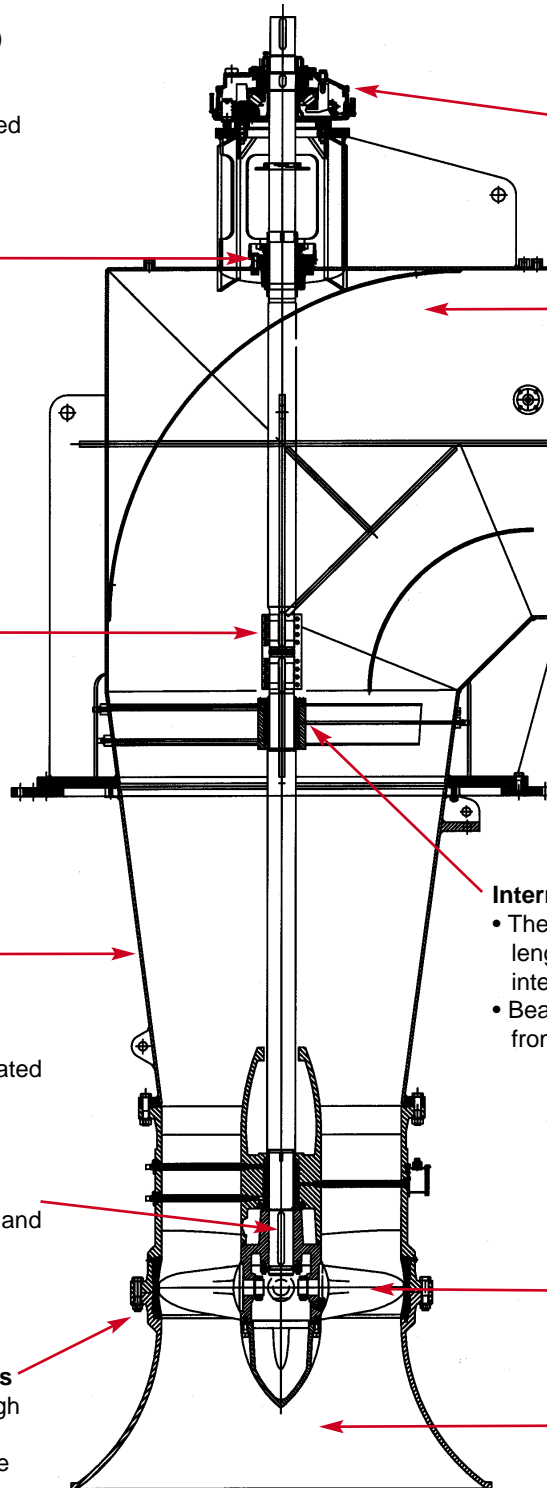

Pump Manufacturing Facilities

Cranage

- Lifting Capacity 37.5 tons

Machine Tool Capacity

- Up to 15 tons

Outsourcing

- Items such as large castings and or fabrications which fall outside our existing scope of machining capabilities are subcontracted.

Quality Assurance

- Sulzer South Africa is accredited for pump design and manufacture to ISO 9001



Materials

Name of Part	Material
Casing Segment, Impeller, Stage Casing and Suction Flare/Bellmouth	Depending on the operating conditions, they are available in cast iron, cast steel, chrome-nickel cast steel, austenitic steel, duplex stainless steel or bronze.
Shaft and Coupling	Unalloyed steel, chrome-steel, austenitic steel, duplex stainless steel or Monel, to meet the respective operating requirements
Rising Pipe, Motor Pedestal	In accordance with the medium being handled and pump size, of welded or cast design (alloyed or unalloyed)
Radial Bearings	Rubber or metal, according to the medium being handled.

Typical Alternative Arrangements

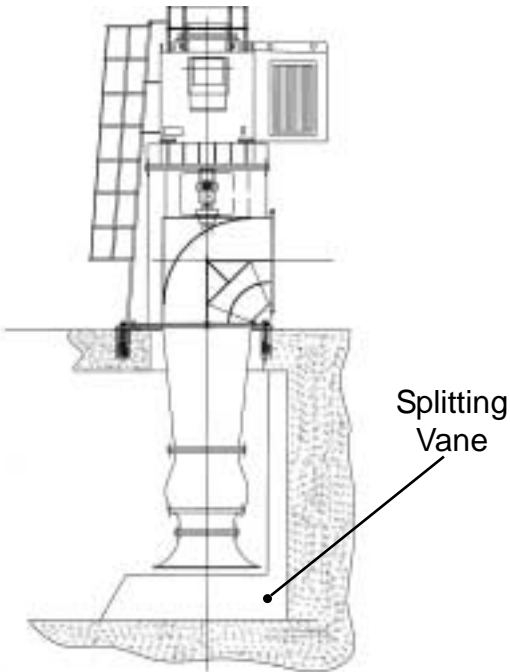

Above Floor; Close Coupled; Motor supported on Pump

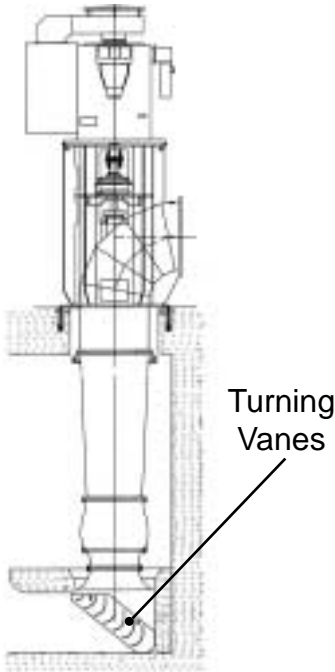

Above Floor; Close Coupled with Turning Vanes

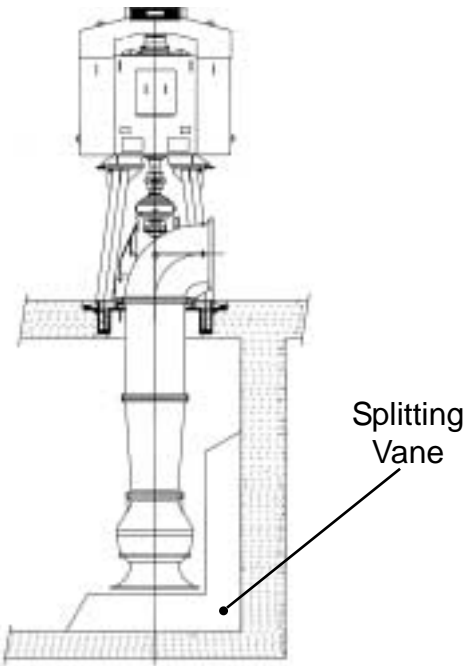

Above Floor; Close Coupled; Motor separately supported

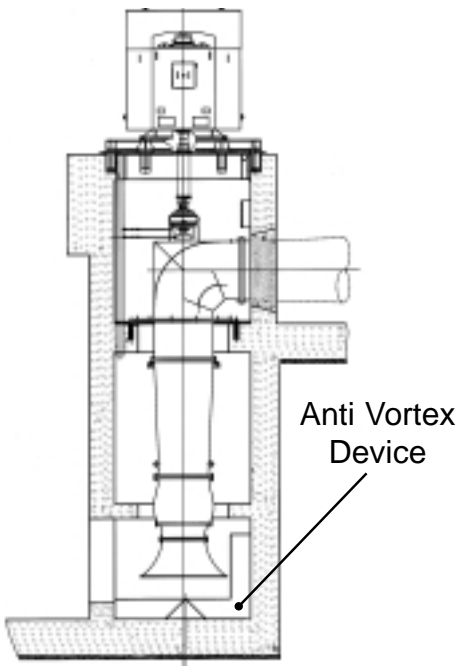

Above Floor; Drive Shaft; Motor on separate floor

Test Bed

Our pump testing facility is the largest in Africa, with 3,3; 6,6 and 11kV electrical supply installed and capable of running motors up to 4 MW. With a sump of 30m long, 6m wide and 10m deep, all makes of centrifugal pumps can be tested up to a flow rate of 60'000 m³/hr.

Tests can be performed to BS, DIN, API, HI or ISO specifications.

The parameters investigated are:

- Flow rate
- Suction and delivery pressures (total head capability)

- Power consumption
- Pump efficiency
- Net positive suction head (NPSH)
- Vibration and temperature, on request

The result of every test is documented with a report including:

- Performance chart of the pump; head, power, efficiency and NPSH as a function of flow rate

- Relevant pump data
- Records of measurement taken during testing
- Summary of results
- Interpretation and recommendations.



Vertical Pump Intake Design Using Turning Vanes

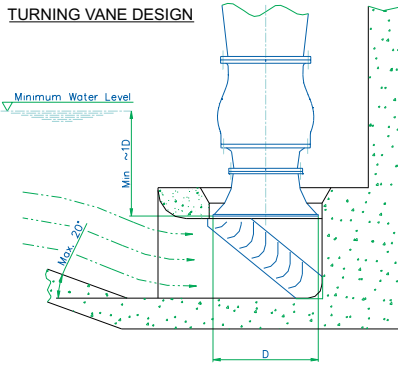

Turning Vane design offers space savings, cost savings and Peace of Mind.

The intake design function is to guide a flow of water to the suction bell and impeller inlet of a vertical pump with minimum disturbances from vortices, uneven velocity profiles or excessive pre-rotation assuring trouble-free pump operation.

Unsatisfactory flow approach creates vortices in the vicinity of the suction bellmouth, causing uneven flow distribution to the pump; in turn resulting in high noise levels, vibrations, efficiency loss and possible cavitation.

It is a know fact that the majority of all wet-pit pump failures result from improper intake design.

A very specific problem area is the slope of the bottom of the flow channel towards the pumps, prevalent to pumps in cooling tower applications. Here the highest approach velocities stay in the upper layer of the flow and cause unstable sinking flow around the pump with potential for vortex formation. Adhering to low slope angles to minimize this problem results in very long and expensive intake structures.

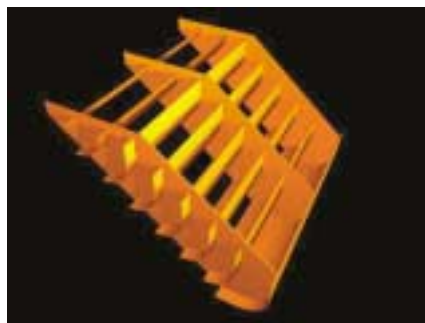
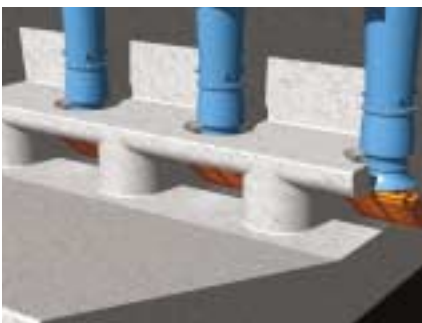
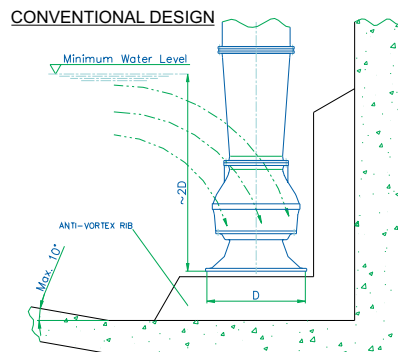

Head Office - Johannesburg

Sulzer (South Africa) Limited

Private Bag X23
9 Gerhardus Road
Elandsfontein 1406
South Africa
Tel: +27 (0)11 820 6000
Fax: +27 (0)11 820 6205
Internet: www.sulzerpumps.com

BRANCHES

Durban

4 Moss Road
Westmead, Pinetown 3610
Private Bag X09
Ashwood
3605
Tel: +27 (0)31 700 4821
Fax: +27 (0)31 700 3549

Cape Town

Unit 14A, Tamric Park
Calcutta Street, Paarden Eiland
P O Box 2007
Cape Town 8000
Tel: +27 (0)21 510 2406
Fax: +27 (0)21 510 2438

Welkom

11 Fourteenth Street
Voorspoed East
P O Box 1202
Welkom 9460
Tel: +27 (0)57 396 4821
Fax: +27 (0)57 396 5619

Nelspruit

P O Box 3106
Nelspruit 1200
Tel: 082 559 8977
(Contact: Ken Malcolm)

Zambia

Stand 603
Station Road, P O Box 10472
Chingola, Zambia
Tel: +926 (0)2 31 2442
Fax: +926 (0)2 31 3691