

SULZER

Sulzer Pumps

SJP Vertical Propeller Pumps

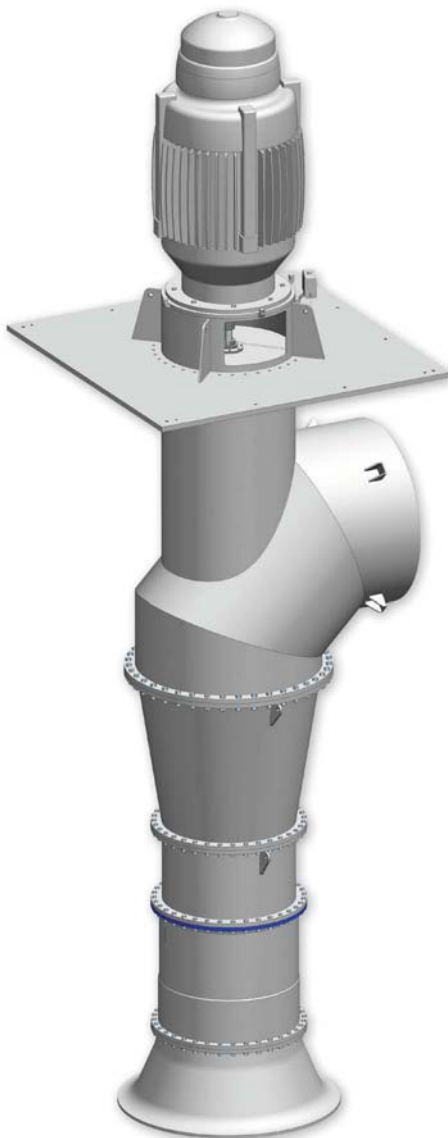

The Heart of Your Process

Sulzer Pumps

Sulzer Pumps is a world leader in reliable products and innovative pumping solutions. Our advanced research and development, detailed process and application knowledge together with a comprehensive understanding of market demands keeps us consistently at the leading edge of technical development. Our global network of modern manufacturing and packaging facilities together with sales offices, service centers and representatives located close to major markets provide fast responses to customer needs.

Sulzer Pumps has a long history of providing innovative pumping solutions to business partners in the following industries:

- Oil and Gas
- Hydrocarbon Processing
- Pulp and Paper
- Power Generation
- General Industry
- Chemical Process Industry
- Water and Wastewater



Sulzer Pumps Houston manufacturing site

Application Knowledge for Better Efficiency

Vertical Propeller Pumps

Vertical propeller pumps are typically used whenever a liquid needs to be pumped upward at low pressure from open bodies of liquid such as oceans, rivers, lakes, cooling ponds, tanks and sumps. Special design and new materials have made propeller pumps ideal for municipal water supply, drainage, flood control, power plant intake and industrial uses of all types. There is an ever increasing demand for the efficient management of the world's water resources. A better understanding of water applica-

tion problems, increased production demands plus sophisticated facility and equipment design have created the need for superior high capacity low head pumping capabilities

Advantages

- Minimum use of floor space.
- The NPSH available can be at the lowest level to satisfy the NPSH requirements of the pump.
- No priming required, the pump bowl assembly is submerged in the fluid being pumped.
- The variety of materials and

construction possibilities to meet special requirements (such as corrosion resistance) is virtually unlimited.

- The vertical propeller pump is adaptable to various design codes.
- Easily modified for changing hydraulic conditions.
- Low operating speeds.
- Sulzer hydraulics deliver high pump efficiencies.

Extensive Product Range

The SJP propeller pump is an “engineered to order” vertical axial flow pump and has a capacity range up to 54,500 m³/h (240,000 USgpm) with a total maximum single stage head up to 12 m (40 ft) in sizes ranging from 200 to 2,120 mm (8 to 72 inches) in bowl diameter.

The SJP can be manufactured from a variety of metallurgies to extend pump life and performance. Above and below base discharge connections are available to suit all existing pipe design variants.

Engineered for Application Flexibility

Sulzer industrial vertical propeller pumps are high capacity, low head units widely used for circulating services in nuclear and conventional power plants, raw water supply to process plants or refineries, large irrigation projects, flood control and numerous other applications. Common types of fluids handled include water, service water, and waste water. Performance and hydro testing are in accordance with the Hydraulic Institute Standards and can be witnessed or non-witnessed, depending on customer preference. The SJP pump is engineered to balance high efficiency, low submergence and NPSH considerations. SJP pumps are designed for continuous service for extended periods of time.



Materials

Cast parts	cast iron, carbon steel, 316SS, duplex, super duplex, bronze
Shafts	12% Chrome, 316SS, duplex, super duplex, monel
Fabrications	carbon steel, 316L, duplex, super duplex
Bearings	rubber lined bronze, duplex, super duplex

SJP Design Features and Benefits

Shaft Seal

As a standard, a packed stuffing box is provided for reliable sealing and simple maintenance. Multiple stuffing box options are available to include shaft enclosing tube (for oil or water flush) or various types of mechanical seals.

Pumpshaft

The shaft is tailor-made to the service needs and sized individually for each installation; sized for maximum torque. A stepped shaft with sleeves can be supplied.

Bowl Bearing

Bowls are fitted with dual metal and rubber bearings.

Propeller

The SJP impellers are propeller-type, offered in several materials as applications demand, balanced to assure vibration-free operation and polished to optimize performance. The impeller is secured to the shaft by a key and split thrust ring. The axial flow propeller has a single inlet, available in numerous pitch positions to allow for maximum capacity handling.

Headshaft

Precision machined and sized for the application power input. The headshaft can be supplied with a nut or flanged coupling for impeller adjustment to maximize sustained efficiency. Headshaft material is selected to suit the pumped fluid.

Discharge Head

A below ground discharge head is standard featuring a segmented elbow designed to optimize pump efficiency. The elbows are fabricated in various materials to meet many required applications.

Column Assembly

Column pipes are flanged. Line shafts are connected by split ring, key and sleeve couplings. Line shaft bearings are replaceable. Column assemblies have integral spiders.

Bowl

The bowl is flanged and connects directly to the column pipe. The design combines the energy conversion and diffusion functions of the intermediate bowl and discharge case all in one casing. Replaceable nickel aluminum bronze bearings are provided to extend bowl and shaft life. A replaceable liner is available to increase pump life.

Suction Bell

Each suction bell includes vanes that lend support to the tail bearing, while guiding the liquid flow parallel to the drive shaft for maximum efficiency. Suction bells can be fitted with strainers to restrict entry of foreign objects during pump operation.

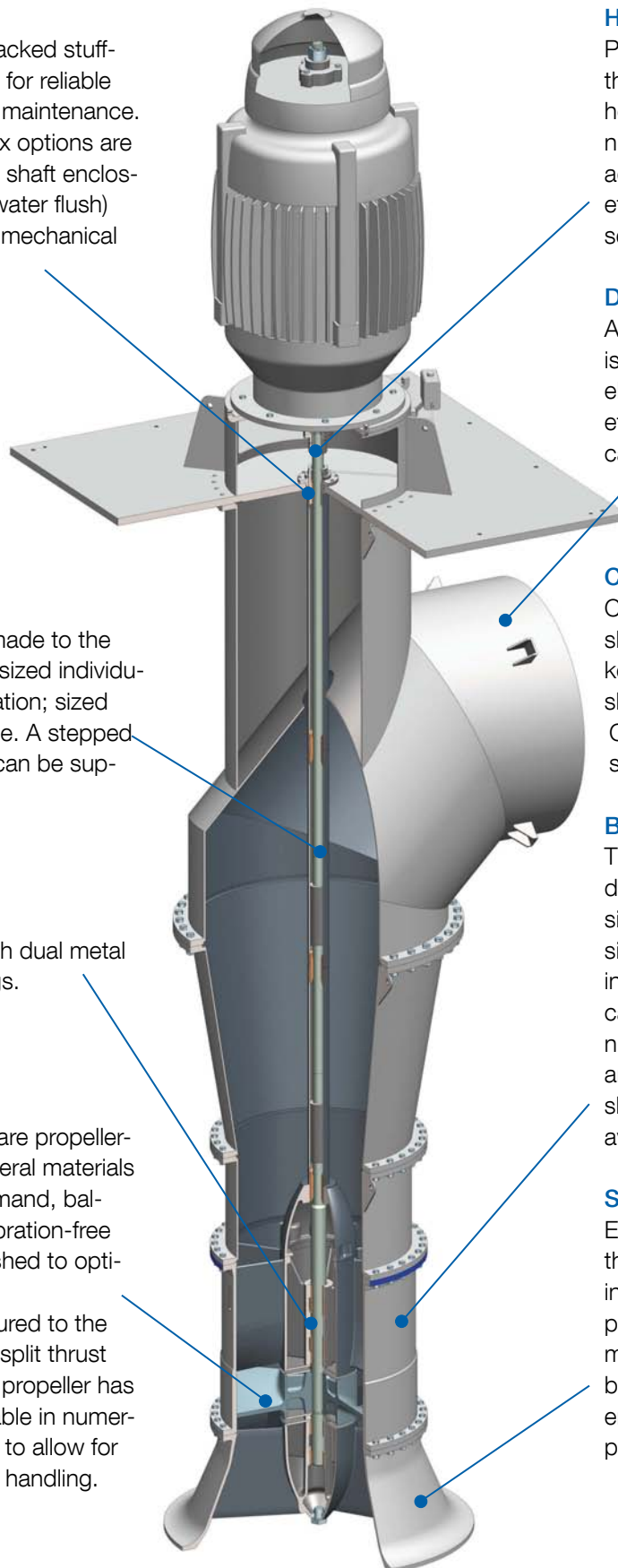

Thrust Bearing Assembly

Thrust bearing assemblies are available when required by the application. They are built to handle all the down thrust produced by the pump and any momentary up thrust may occur. The flexible coupling with spacer allows servicing the thrust bearing and mechanical seal as needed. A one-piece fabricated motor stand housing is bolted down over the discharge head to protect the bearing and support the motor.

Optional features include sandstorm protection, special means for cooling and a constant level oil lubricator.

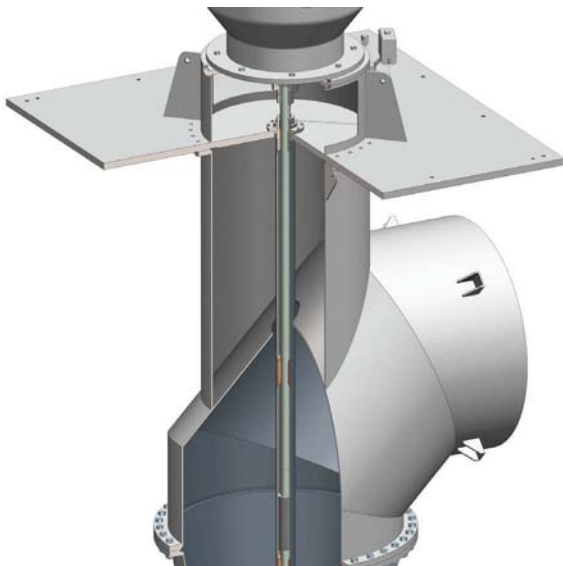
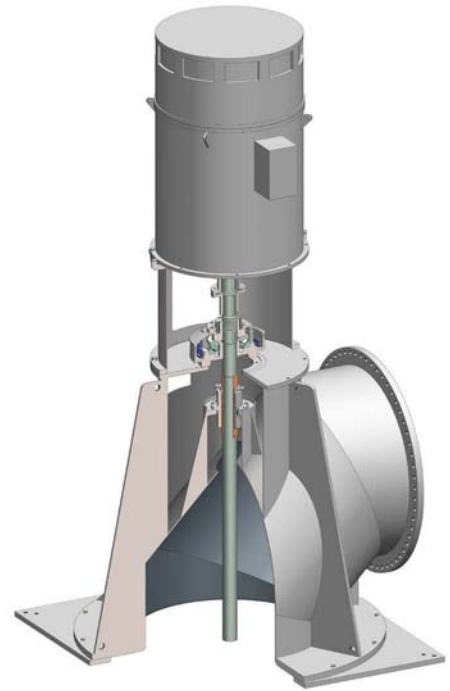

Discharge Head

The discharge nozzle can be either plain-end or flanged. The motor stand is mounted above ground and is designed to support the motor weight and provide maximum clearance for multiple stuffing box options. These options include gland packing, shaft enclosing tube and mechanical seal.

An above ground discharge head can also be provided. The integral driver stand allows easy access to removable packing/seal box and coupling. Each standardized discharge head comes with a segmented bend/motor stool and utilizes a stuffing box designed to accommodate various mechanical seals.

Fabricated Bowl and Bell

Fabricated bowls and suction bells are an available option for pumps sizes 1,450 mm (50 inches) and bigger. The fabricated bowls are provided with diffuser vanes to help optimize bowl efficiencies. The suction bell includes vanes that lend support to the tail bearing. Each component is available in Steel, 316SS and Duplex to service many different applications.



SJP Performance Range

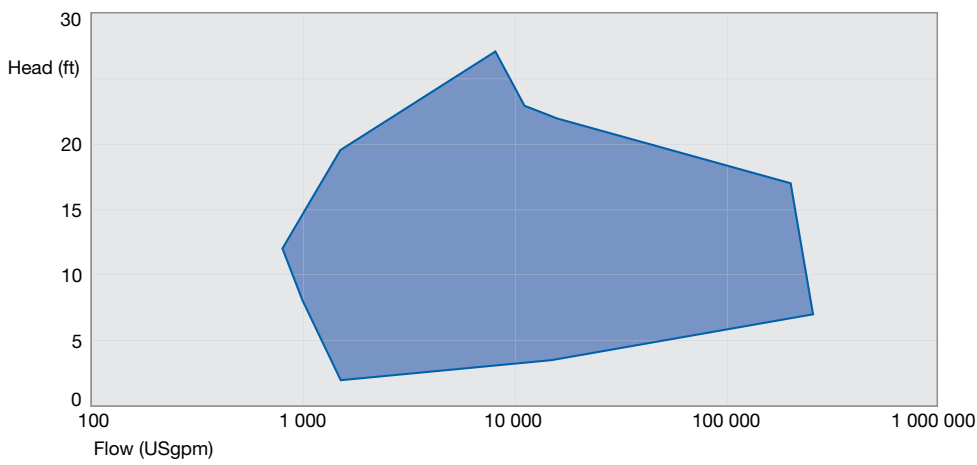
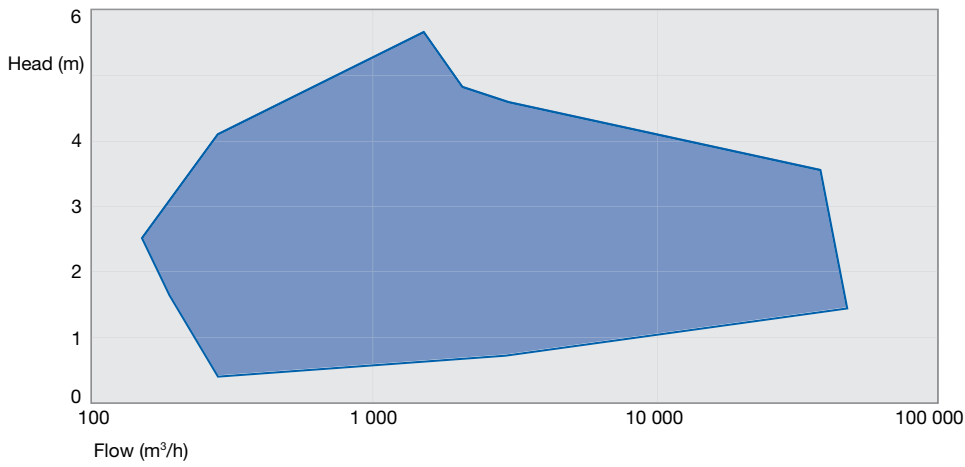

Operating Data

	SJP 50 Hz	SJP 60 Hz
Pump sizes	200 to 2,120 mm	8 to 72 inches
Capacities	200 to 54,500 m ³ /h	900 to 240,000 USgpm
Heads	up to 12 m	up to 40 feet
Pressures	up to 2 bar	up to 30 psi
Temperatures	up to 50 °C	up to 120 °F

Maintaining and Improving Pump Performance

Sulzer Pumps – Customer Support Services

The continuous availability and high operating performance of pumps is the key target for our customer support service organization.

Through our highly experienced personnel and application knowledge, we provide a full range of innovative service solutions to our customers to keep their pumps running including:

- Spare Parts
- Field Services
- Repair Services
- Retrofits
- Maintenance Agreements
- Operation Agreements

Flexibility

With services ranging in scope from supplying a spare part to operating the pump under contract, we are uniquely placed to make your process run smoother. A dedicated team of our service specialists based at either our manufacturing facilities or one of over 60 service centers located around the world is dedicated to maintaining the performance of our customers' pumps and associated equipment. This service is not just limited to Sulzer products, all the pumps our customers operate can benefit from the support of Sulzer Pumps.

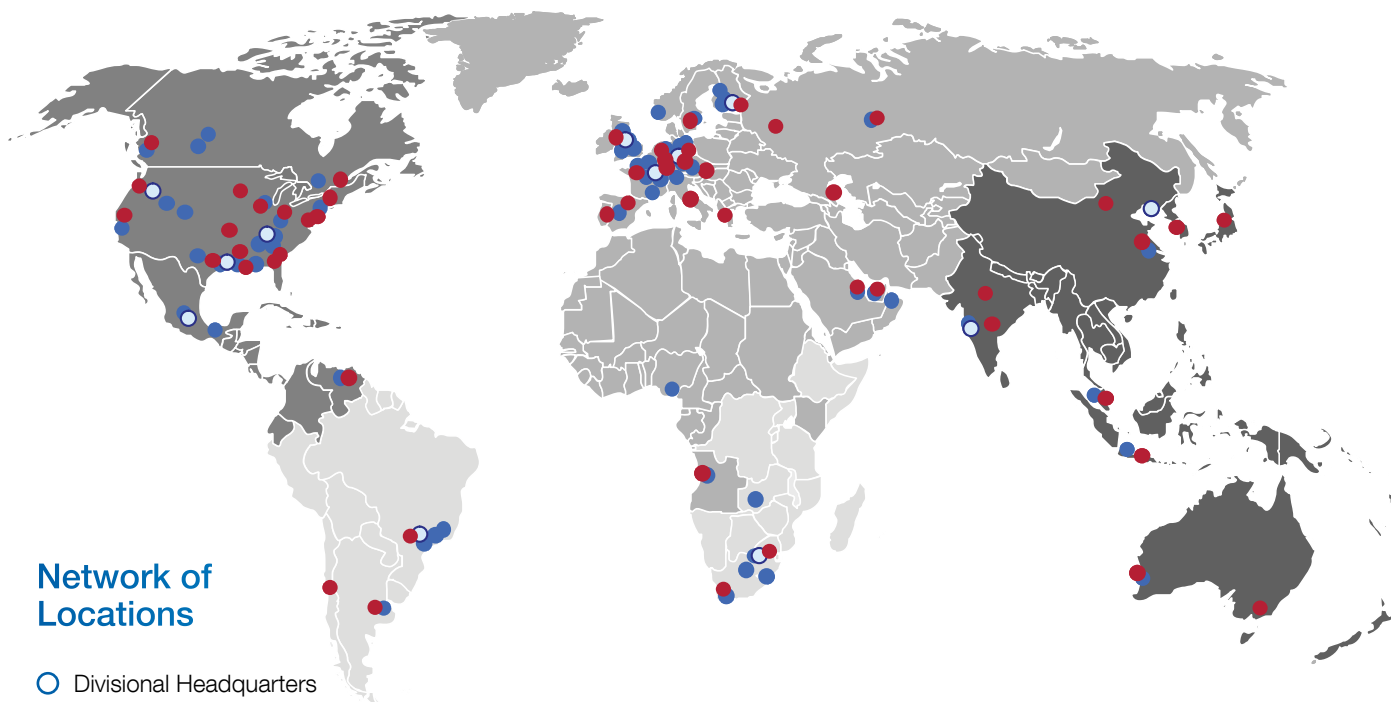
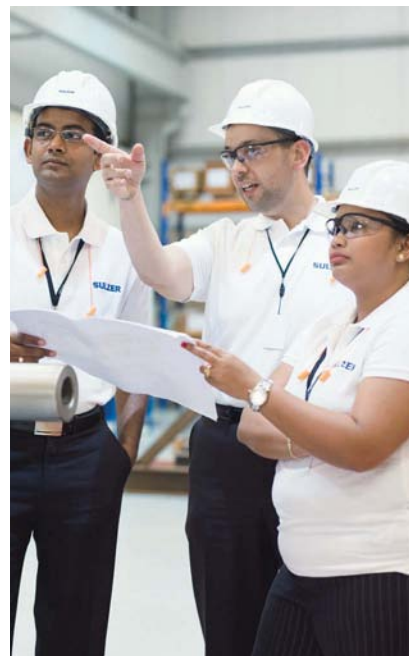

Network of Locations

- Divisional Headquarters
- Manufacturing Facility
- Customer Support Service Center (CSS)
- Sales Office

www.sulzerpumps.com

E10024 en 9.2010 (1000), Copyright © Sulzer Pumps

This brochure is a general presentation. It does not provide any warranty or guarantee of any kind. Please, contact us for a description of the warranties and guarantees offered with our products. Directions for use and safety will be given separately. All information herein is subject to change without notice.