

**SULZER**

Sulzer Pumps

# Your Partner for Concentrated Solar Power Generation



**The Heart of Your Process**



## Experience and Solutions You Can Rely on

Around the world, the power industry is taking on the challenge to produce clean, dependable energy from renewable resources. Concentrated Solar Power Generation (CSP) provides a sustainable solution to energy needs today and in the future. Sulzer Pumps has been working with customers to provide reliable and cost-effective solar power since supplying pumps to a CSP plant in 1984.

We combine our expertise in Solar Power and in other renewable technologies, such as hydro, geothermal, and biomass, with our experience in fossil-fired and nuclear power plants to develop and tailor pumps and auxiliaries that meet the unique demands of CSP.

### Understanding Your Process

With Sulzer Pumps, you have the single-supplier advantage of our comprehensive portfolio, which supports the leading solar technologies and all major processes in a CSP plant. From a single pump to a total system solution, we work closely with you to develop the best pump solution. We focus on delivering efficient, total life cycle performance to enable you to produce competitive solar power.

The daily start-and-stop and temperature fluctuations in CSP operations place extreme demands on all components in your system. You need a pump solution that gives you lifetime reliability with increased output, high efficiency, and improved Mean Time Between Maintenance (MTBM). Sulzer Pumps answers this need with a full line of steam generator feed water, cooling water and condensate extraction pumps for all CSP technologies: Heliostat Fields, Parabolic Trough Collectors (with and without molten salt heat storage), Linear Fresnel Reflectors and Hybrid Integrated Solar Combined Cycle (ISCC) processes.

### About Sulzer Pumps

Sulzer Pumps is recognized for excellent product quality, performance reliability and technical innovation. We provide a full line of pumps, equipment and related technologies to the Oil and Gas, Hydrocarbon Processing, Power Generation, Pulp and Paper, Water and Wastewater and General Industries. Combining global capabilities, local market understanding and application expertise we support customers with more than 150 locations around the world, including manufacturing facilities, sales offices and service centers close to our customers.



## Heliostat with Central Tower and Direct Steam Generation

Using a Central Solar Tower, Heliostat fields involve direct steam generation provided with a certain steam storage capacity. Sulzer Pumps supports these processes with pumps for Feed Water (FWP), Hot Water Circulation (CP), Condensate Extraction (CEP) and Cooling Water (CWP).

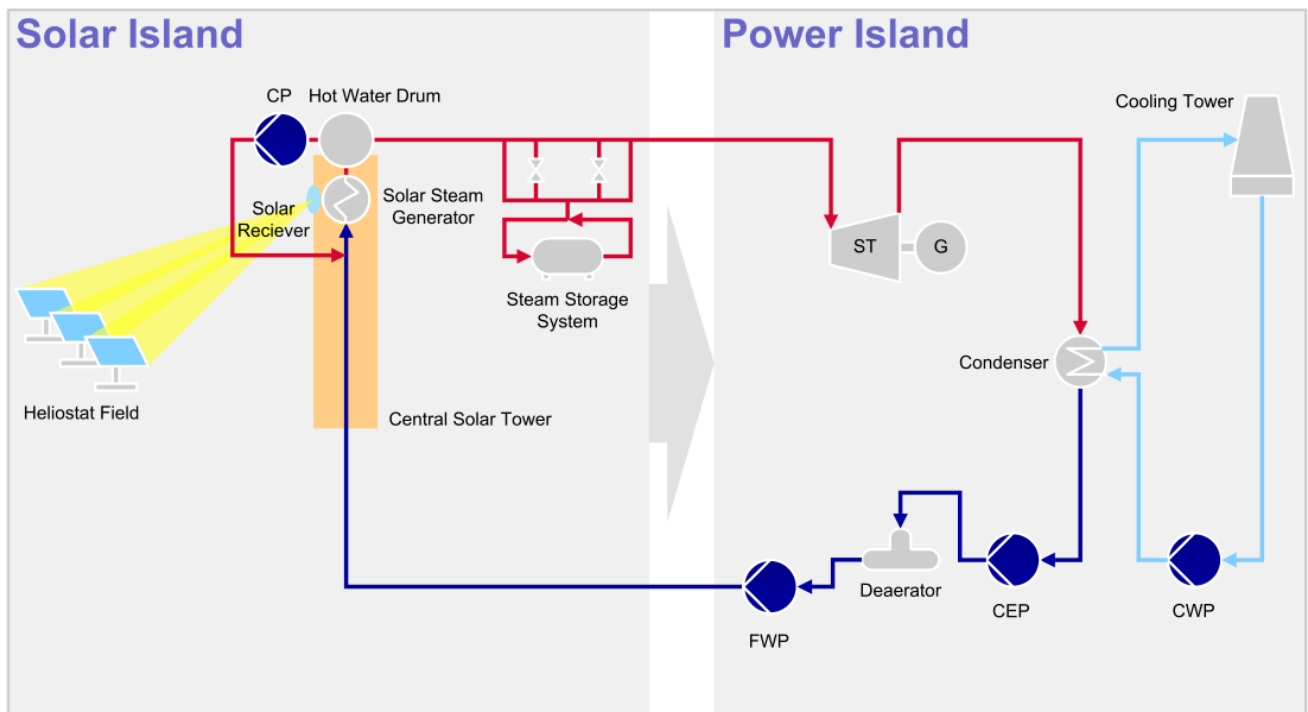

ST = Steam Turbine

G = Generator



## Heliostat with Central Tower and Molten Salt Heat Storage

Using a Central Solar Tower, Heliostat fields heat up the molten salt. The molten salt is used as primary heat transfer fluid and also to store heat generated in this process. Sulzer Pumps supports these processes with pumps for Feed Water (FWP), Condensate Extraction (CEP), Cooling Water (CWP) and Molten Salt Circulation.

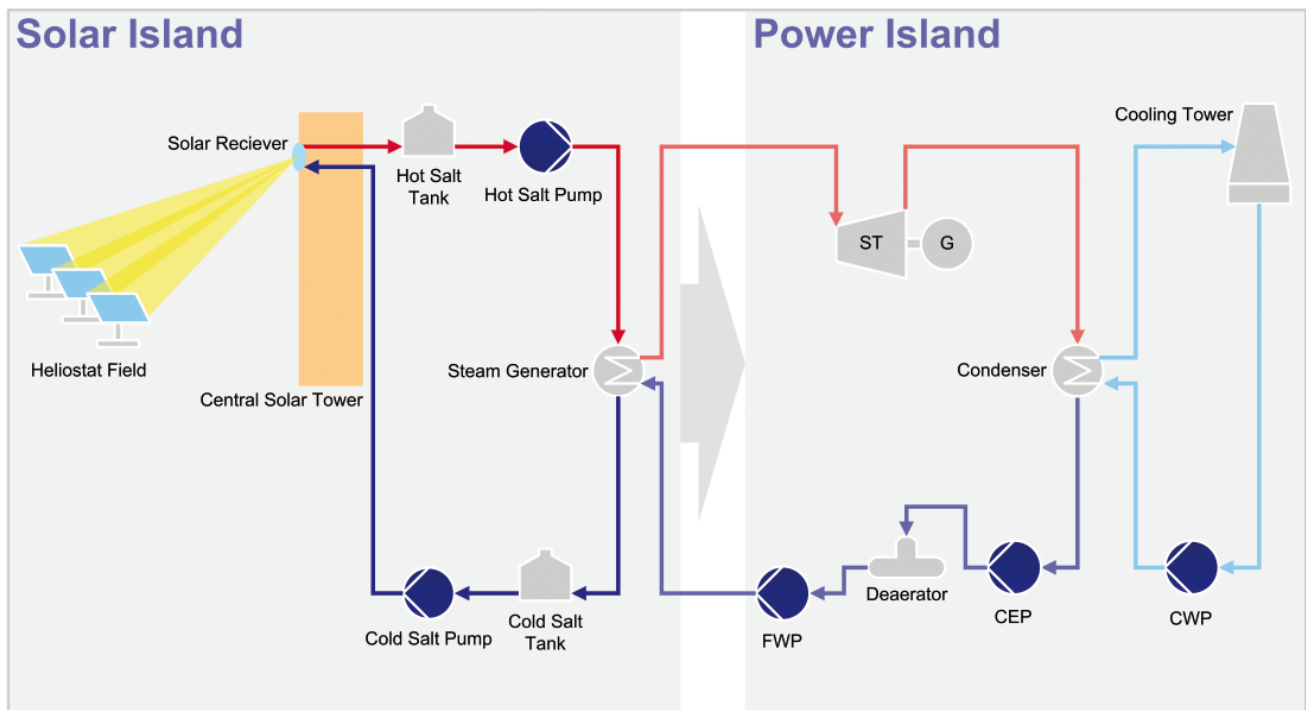

ST = Steam Turbine

G = Generator



# Linear Fresnel Reflector with Direct Steam Generation

Using Linear Fresnel Reflector, collectors involve direct steam generation provided with a certain steam storage. Sulzer Pumps supports these processes with pumps for Feed Water (FWP), Condensate Extraction (CEP) and Cooling Water (CWP).

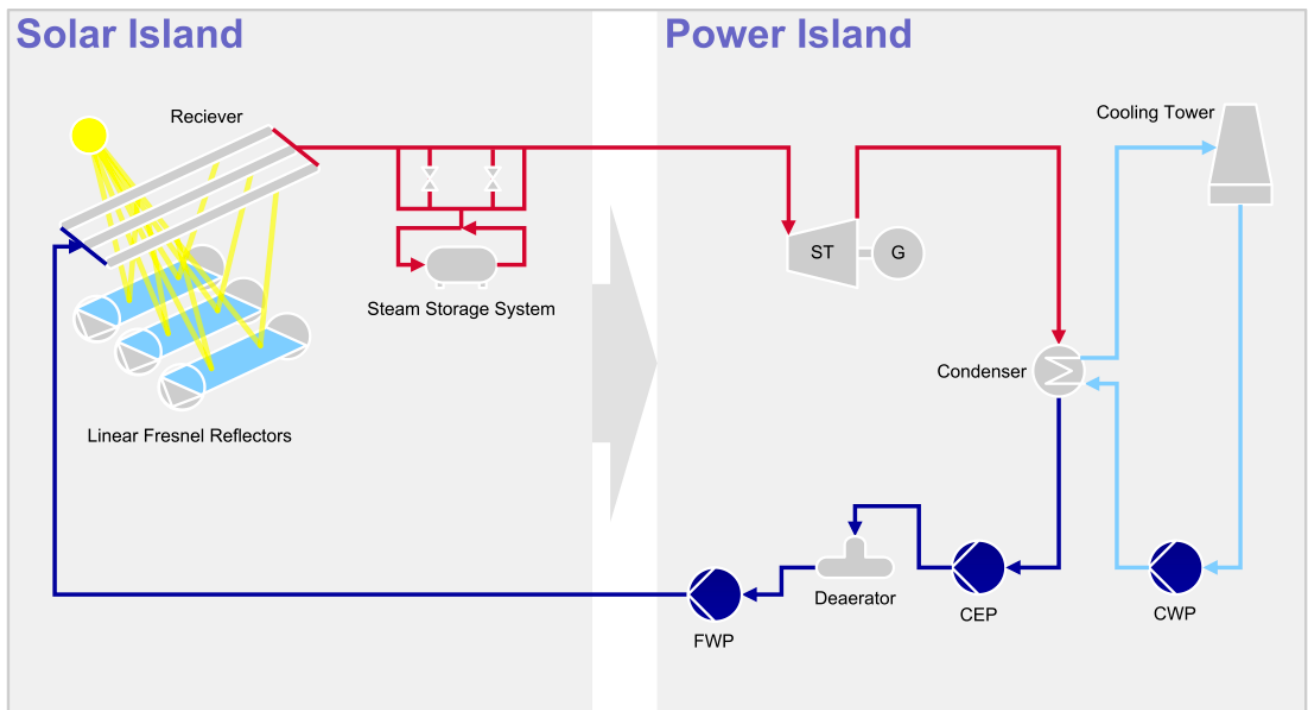

ST = Steam Turbine

G = Generator



## Parabolic Trough without Heat Storage

This system is using thermal oil as primary heat transfer fluid heated up to around 400 °C. It is continually pumped through the solar field with high and variable flow rates and temperatures. Sulzer Pumps equipment for these operations includes pumps for Feed Water (FWP), Condensate Extraction (CEP), Cooling Water (CWP) as well as Main and Auxiliary pumps for Heat Transfer Fluid (HTF).

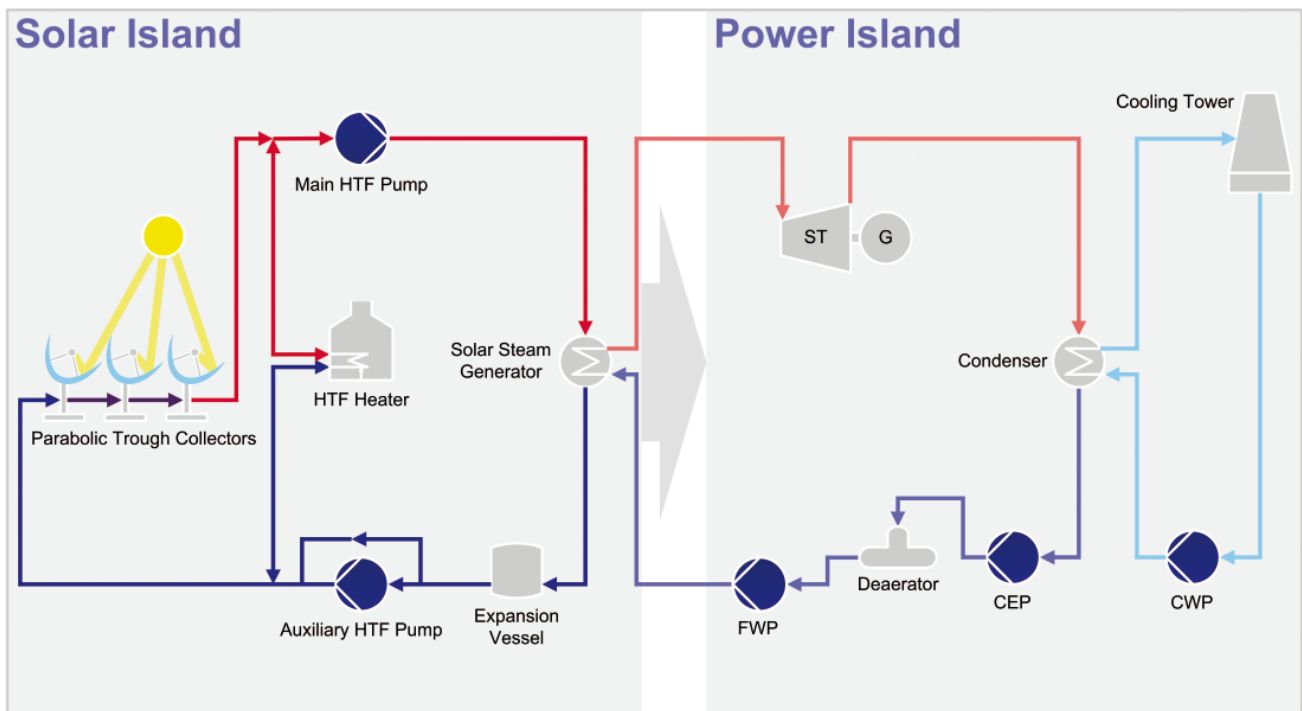

ST = Steam Turbine

G = Generator



## Parabolic Trough with Molten Salt Heat Storage

Parabolic Trough Collector systems are using thermal oil as primary heat transfer fluid to heat up the salt. The molten salt is used as secondary heat transfer fluid to store heat generated in this process. Sulzer Pumps equipment for these operations includes pumps for Feed Water (FWP), Condensate Extraction (CEP), Cooling Water (CWP), Molten Salt Circulation, as well as Main and Auxiliary pumps for Heat Transfer Fluid (HTF).

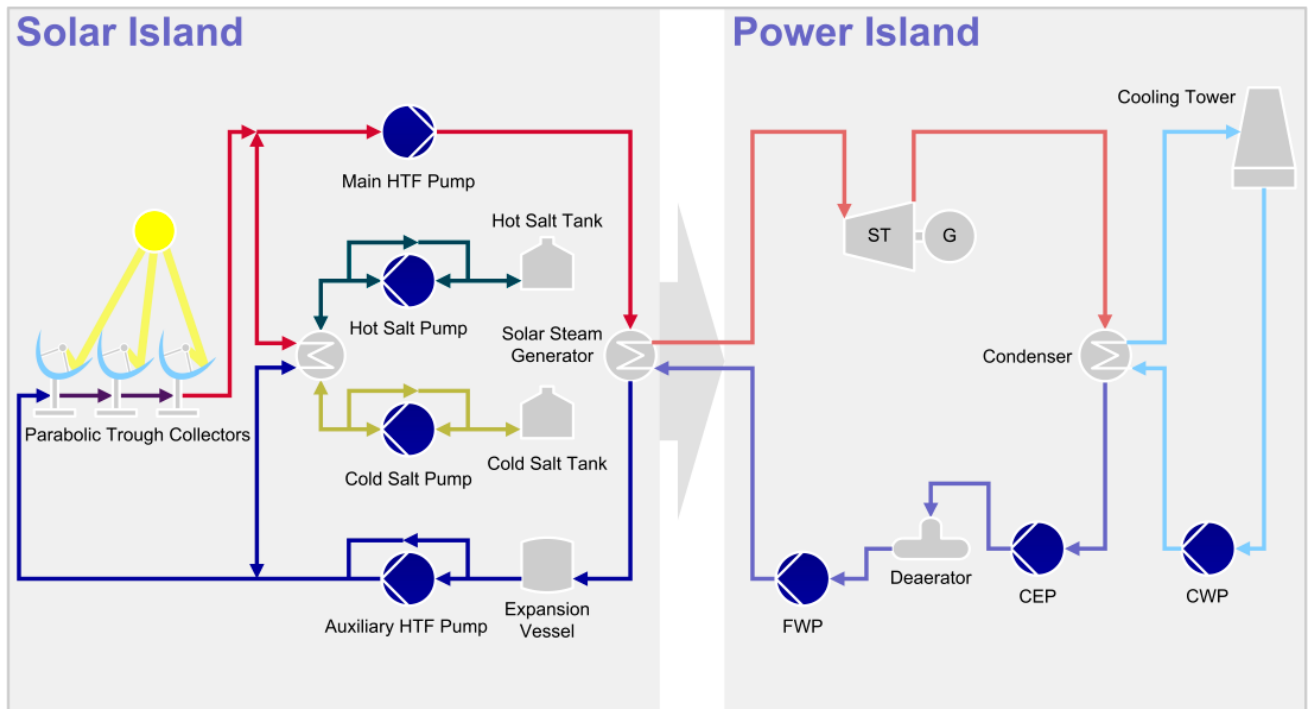

ST = Steam Turbine

G = Generator



## Hybrid Integrated Solar Combined Cycle (ISCC)

This process uses parabolic trough collectors and thermal oil as primary heat transfer fluid. Sulzer Pumps equipment includes pumps for Feed Water (FWP), Condensate Extraction (CEP), Cooling Water (CWP), as well as Main and Auxiliary pumps for Heat Transfer Fluid (HTF).

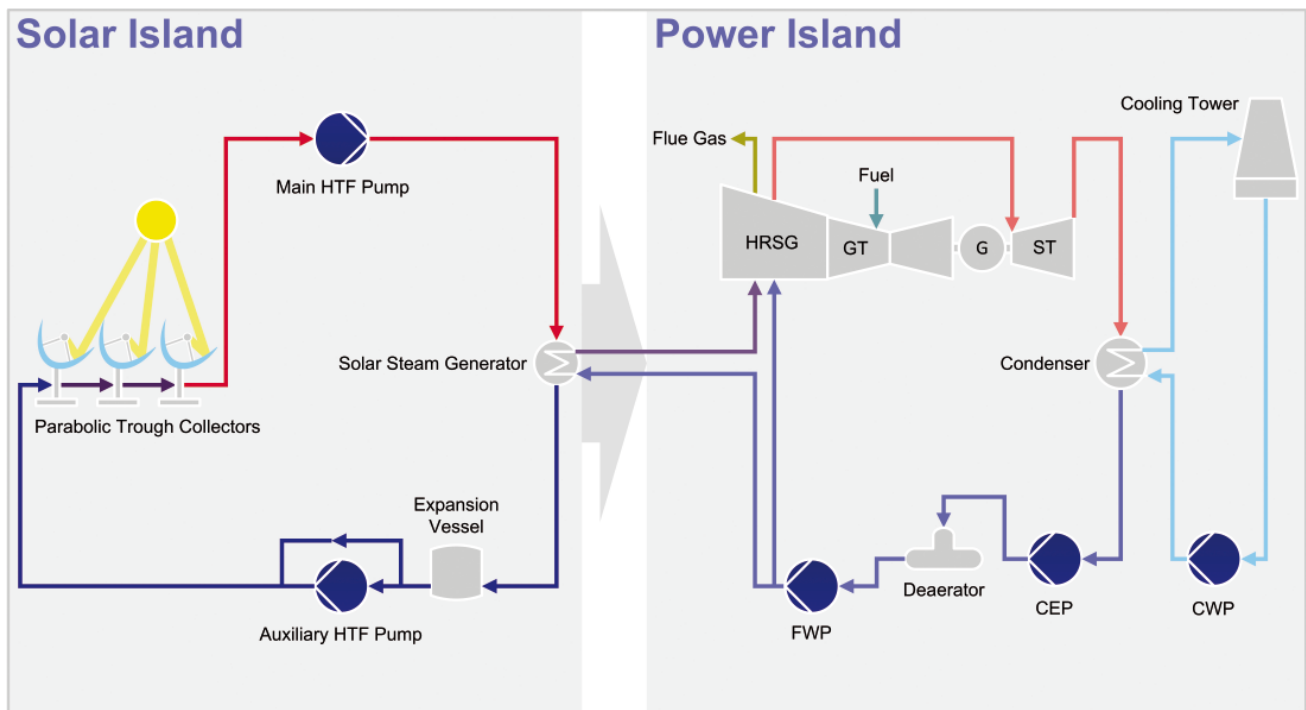

HRSG = Heat Recovery Steam Generator

GT = Gas Turbine

G = Generator

ST = Steam Turbine



## Meeting Your Most Demanding CSP Needs

Reliable and cost-effective CSP plant performance begins with the selection of the right equipment and continues with the constant life cycle monitoring. Drawing on our extensive portfolio of products and services, we will work with you to select and customize pumps to comply with your requirements.

Process	Pump Applications							
	Feed Water (FWP)	Condensate Extraction (CEP)	Cooling Water (CWP)	Hot Water Circulation (CP)	Heat Transfer Fluid (HTF) Main	Heat Transfer Fluid (HTF) Auxiliary	Molten Salt Circulation	Auxiliary Service
<b>Heliostat with Central Tower and Direct Steam Generation</b>	MC MD MBN GSG MSD	SJD (CEP)	SMD/SMN ZPP SJT SJM	ZE ZF				AHLSTAR
<b>Heliostat with Central Tower and Molten Salt Heat Storage</b>	MC MD MBN GSG MSD	SJD (CEP)	SMD/SMN ZPP SJT SJM				SJT (VCN)*	AHLSTAR
<b>Linear Fresnel Reflector with Direct Steam Generation</b>	MC MD MBN GSG MSD	SJD (CEP)	SMD/SMN ZPP SJT SJM					AHLSTAR
<b>Parabolic Trough without Heat Storage</b>	MC MD MBN GSG MSD	SJD (CEP)	SMD/SMN ZPP SJT SJM		ZF HZB BBS CD	ZE/ZF/OHH OHH/ZEM		AHLSTAR
<b>Parabolic Trough with Molten Salt Heat Storage</b>	MC MD MBN GSG MSD	SJD (CEP)	SMD/SMN ZPP SJT SJM		ZF HZB BBS CD	ZE/ZF/OHH OHH/ZEM	SJT (VCN)*	AHLSTAR
<b>ISCC Integrated Solar Combined Cycle</b>	MC MD GSG MSD	SJD (CEP)	SJT SJM		ZF HZB BBS CD	ZE/ZF/OHH OHH/ZEM		AHLSTAR ZPP SMD/SMN

\* The SJT (VCN) has been developed for Molten Salt Circulation.

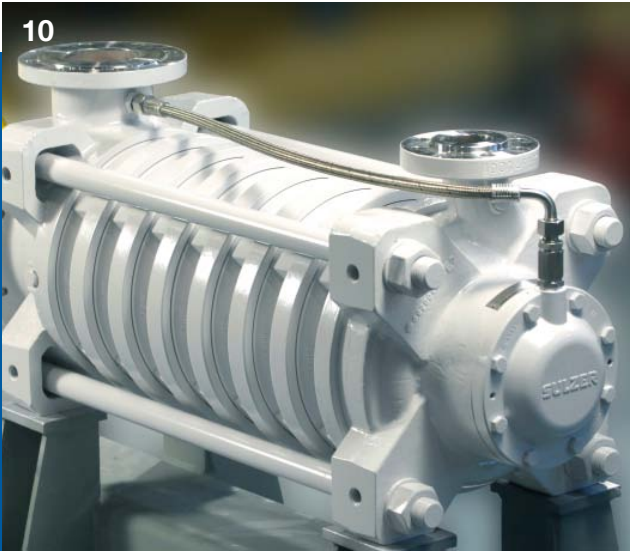

## Pumps for CSP Applications

### Feed Water Pumps

#### MBN

The MBN ring section multi-stage pump is the ideal choice for medium pressure pumping applications. The pump is offered in a wide range of materials including chrome steel and duplex stainless steel grades. The pump utilizes integrated diffusers and a product lubricated NDE bearing to simplify construction, minimize dimensions and reduce cost.

**Pressure 100 bar / 1,450 psi**  
**Temperatures 180 °C / 355 °F**



#### MSD

MSD multistage pumps are widely used in power generation applications. The broad range of standard hydraulics and mechanical design options ensure optimum fit to customers' duty requirements, using proven pre-engineered solutions.

**Pressure 310 bar / 4,500 psi**  
**Temperatures 200 °C / 400 °F**



#### MC/MD

MC/MD pumps are horizontal, radially split ring section multi-stage pumps of modular design. MC/MD pumps are suitable for pumping clean or slightly polluted, hot or cold, chemically neutral or aggressive liquids. These pumps are primarily designed for power applications, i.e. boiler feed and condensate services in power plants.

**Pressure 180 – 270 bar / 2,600 – 3,900 psi**  
**Temperatures 180 – 210 °C / 355 – 410 °F**



#### GSG

The GSG pump is a horizontal, radially split, diffuser type, multi-stage barrel casing design and is optimized for synchronous speed direct drive applications. The entire cartridge can be removed as an assembly to speed up overhaul.

**Pressure 300 bar / 4,500 psi**  
**Temperatures 425 °C / 800 °F**



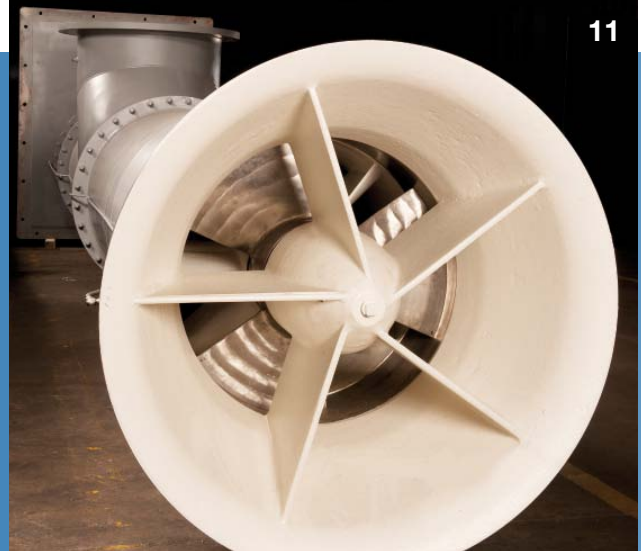

## Condensated Extraction Pumps

### SJD (CEP)

The SJD (CEP) range of vertical pumps is ideal for applications where NPSHA is limited. The pumps are used in a wide range of applications ranging from simple industrial booster pumps to high pressure condensate return and heater drain pumps in power plants.

**Pressure 94 bar / 1,364 psi**  
**Temperature 100° C / 212° F**



Single Suction



Double Suction

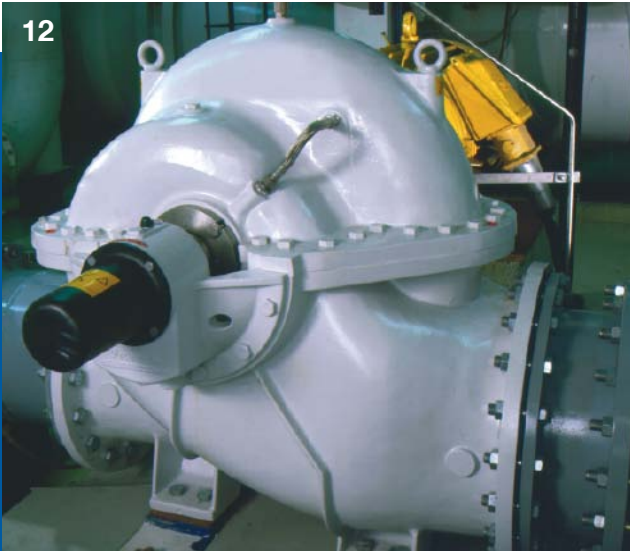

## Cooling Water Pumps

### SMN/SMD

The SMN/SMD single stage double entry pumps are used across a broad range of industries in liquid transport and transfer applications.

**Pressure 30 bar / 435 psi**

**Temperatures 160 °C / 320 °**

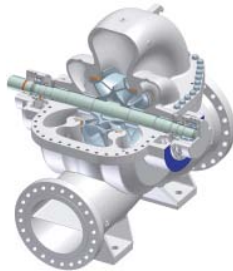

### ZPP

ZPP double suction, axially split pumps are designed for cooling water services in power plants and other industries requiring low pulsation and high efficiencies.

**Pressure 10 bar / 150 psi**

**Temperatures 120 °C / 250 °F**



### SJM/SJT

SJM/SJT vertical pumps are ruggedly designed providing long service in a wide variety of applications. The basic components of head, column pipe and bowl assembly are combined and customized to perfectly match individual duty needs.

**Pressure 64 bar / 930 psi**

**Temperature 50° C / 122° F**





## Main HTF Pumps

### ZF

ZF horizontal, single stage, radially split pumps with single flow closed radial impeller are designed for a wide range of applications including HTF and boiler circulation in power plants.

**Pressure 100 bar / 1,450 psi**  
**Temperatures 450 °C / 840 °F**

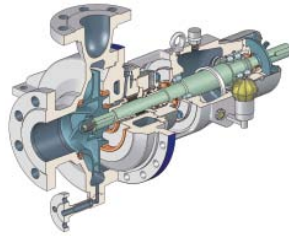

## Auxiliary HTF Pumps

### ZE/OHH

The ZE/OHH pumps are overhung horizontal single stage radially split heavy duty center-line mounted process pumps with single flow closed radial impeller and are ideal for arduous applications including main heat transfer fluid circulation in CSP plants.

**Pressure 60 bar / 870 psi**  
**Temperatures 450 °C / 840 °F**

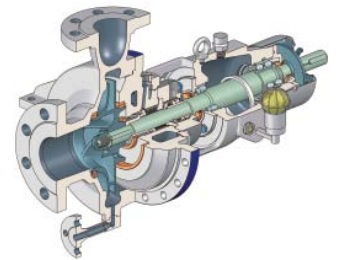

### BBS/HZB/CD

BBS/HZB/CD pumps are primarily used in power plants. The broad pressure and temperature capabilities of this design allow it to be used in the most arduous applications while still providing long service. HZB pumps are designed for hot oil applications.

**Pressure 52 bar / 740 psi**  
**Temperatures 425 °C / 800 °F**



### OHH/ZEM

The OHH/ZEM are the same as the OHH/ZE pumps except that the OHH/ZEM pumps are driven through a magnetic coupling, thus eliminating the need for a mechanical seal and the associated maintenance.

**Pressure 52 bar / 740 psi**  
**Temperatures 250 °C / 480 °F**

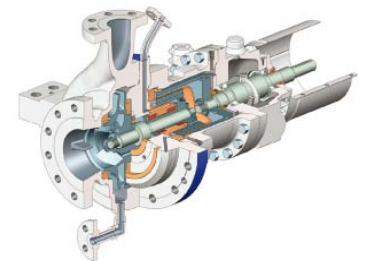



## Molten Salt Circulation Pumps

### SJT (VCN)

The SJT (VCN) pump has been developed to incorporate the hydraulics from the SJT range. It is a vertical mixed flow pump with high capacity and medium to high head units. It is engineered to balance high efficiency, low submergence and NPSH considerations.

The SJT VCN design is a high temperature version developed to comply with the very demanding applications of molten salt circulation in CSP plants.

**Pressure 60 bar / 870 psi**

**Temperatures 600 °C / 1,100 °F**

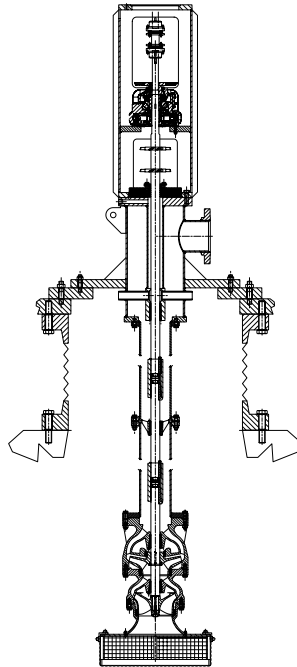



## Auxiliary Services Pumps

### AHLSTAR

AHLSTAR A pumps are used for pumping clean, abrasive or corrosive liquids. Optionally, this pump type can be equipped with the Sulzer Dynamic Seal specially designed for difficult liquids offering reliable operation and low total sealing costs.

**Pressure 16 bar / 230 psi**  
**Temperatures 150 °C / 300 °F**

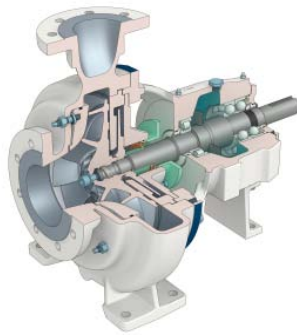

### SMN/SMD

The SMN/SMD single stage double entry pumps are used across a broad range of industries in liquid transport and transfer applications.

**Pressure 30 bar / 435 psi**  
**Temperatures 160 °C / 320 °**

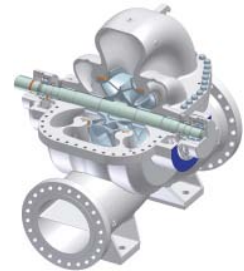

### ZPP

ZPP double suction, axially split pumps are designed for cooling water services in power plants and other industries requiring low pulsation and high efficiencies.

**Pressure 10 bar / 150 psi**  
**Temperatures 120 °C / 250 °F**



[www.sulzerpumps.com](http://www.sulzerpumps.com)



E10052 en (1) 10.2011 (1,000), Copyright © Sulzer Pumps

This brochure is a general product presentation. It does not provide a warranty or guarantee of any kind. Please, contact us for a description of the warranties and guarantees offered with our products. Directions for use and safety will be given separately. All information herein is subject to change without notice.