

# OHM Process Pump API 685 Magnetic Drive

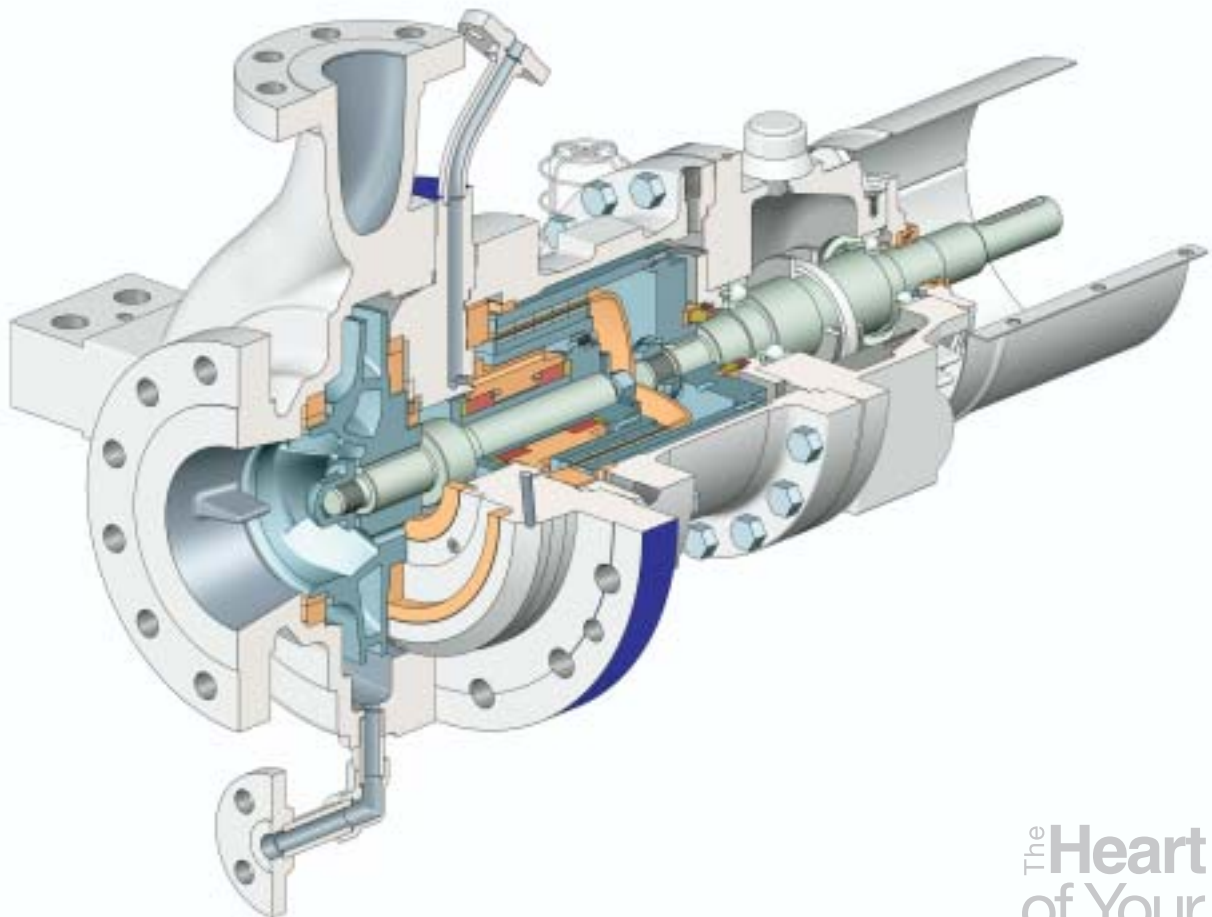

# Sulzer Pumps

Sulzer Pumps combines more than 135 years of experience in pump development and manufacturing with a deep commitment to fully understand the needs of our customers.

Our detailed process and application knowledge has allowed us to develop innovative pumping solutions for our focus segments including tailor made systems if required. Our active research & development supports the customer oriented approach.

Sulzer Pumps has sales and service facilities in all the major markets of the world to provide fast and flexible response and support.

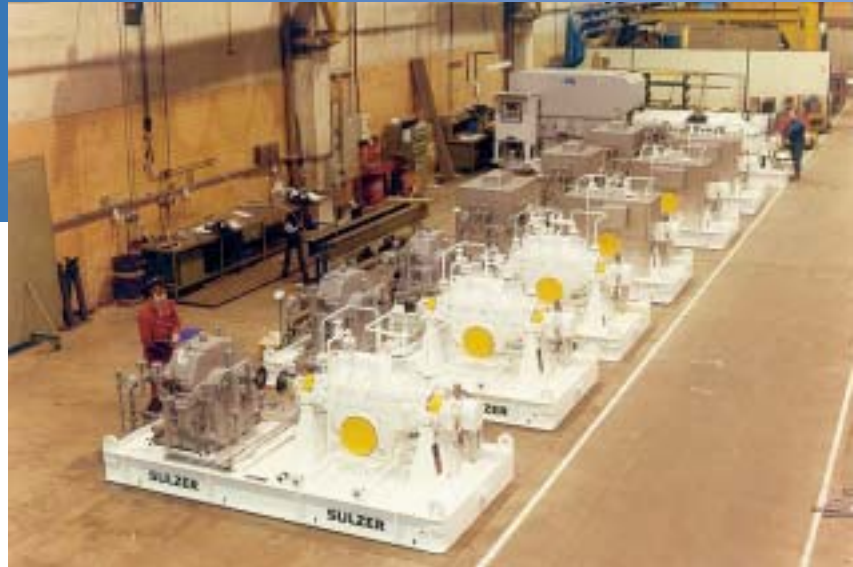

## Extensive Product Range



Sulzer Pumps has a long history of providing innovative pumping solutions to business partners in the following industries:

- **Oil & Gas**
- **Hydrocarbon Processing**
- **Pulp and Paper**
- **Power Generation**
- **Food, Metals & Fertilizers**
- **Water and Wastewater**

### **Hydrocarbon Processing**

Hydrocarbon extraction plants, refineries, petrochemical plants and gas plants operate sophisticated production processes requiring reliable pumping solutions. Continuous product innovations such as our new line of hermetically sealed, horizontal and vertical process pumps, are helping the industry improve its operational efficiency.

Sulzer Pumps, with its high-quality product line, is known for being able to consistently meet these expectations. All our pumps are engineered in line with the latest standards issued by API, ISO and ANSI in order to ensure reliable and safe operation at your site. The Hydrocarbon Processing Industry is one of the core business segments within Sulzer Pumps. Following industry practice, we further subdivide the segment into:

- Synfuels
- Refining
- Gas Processing
- Petrochemicals

The market and therefore our customers require specialty applications for each subsegment.

# OHM - Product Development

## Design

The type OHM overhung process pump includes the latest in sealless pump technology. It is a horizontal, single-stage, radial-split, centerline mounted pump with a high efficiency magnetic coupling. It is a hermetically sealed system, including a secondary containment with a dry running safety seal. The bearings are product-lubricated.



## Type OHM: With Magnetic Drive

OHM pumps are driven through a magnetic coupling, thus eliminating the need for a mechanical seal and the associated maintenance.

Due to the modular system, some elements are interchangeable with the type OHH range. The pump is fully compliant with API 685.

## Rapid Design

For the first time on an entire consolidated product range, Sulzer has used the innovative techniques available from 3D CAD / CAM throughout all aspects of design and development. Hydraulic geometries were created and defined in three dimensions, using Sulzer's own "Volute" and "Impeller" design programs. Designs were checked for conformance, using computational

fluid dynamic studies. The completed designs were then imported, using proprietary Unigraphics software and configured into fully featured solid models suitable for both the direct CNC manufacturing processes and the creation of two dimensional detail drawings. Components for hydraulic development testing were manufactured directly from these solid models.



# Design Features and Benefits

## Efficient Cooling / Flushing System

- Normally fed from full discharge pressure
- Variety of magnetic filters, strainers and coolers available to suit each application
- Backup flow circuit fed from high pressure area behind impeller to assure bearing flow even during upset

## Synchronous Speed High Efficiency Magnetic Drive

- Two types of magnetic drive and containment shell available
- MAK with Hastelloy containment shell
- NMB with patented high efficiency shell for lower losses and higher power levels
- Both are self venting & draining into the pump casing

## Product Lubricated Inner Bearings & Shaft System

- Silicon Carbide radial and thrust bearings
- Radial bearings are self-aligning for higher load capacity
- Designed for both high and low temperature applications
- Extra heavy duty, fully machined inner shaft
- Shaft fully protected by SiC sleeve

## Casing

- Casing, impeller and eye wear rings interchangeable with OHH API 610 pump and OHC API 685 canned motor pump
- Casing designed for 2 times API 685 nozzle loads
- ANSI B 16.5 Cl 300 RF flanges - back-faced as required by API 685
- 3 mm (1/8" in.) corrosion allowance as required by API 685
- Fully supported on API 610 / 685 baseplate

## Impeller

- Enclosed for high efficiency
- 11,000 Nss or less standard design; Lower NPSHr design optional > 2" discharge
- Hydraulically balanced for low axial loading
- Dynamically balanced per API 685

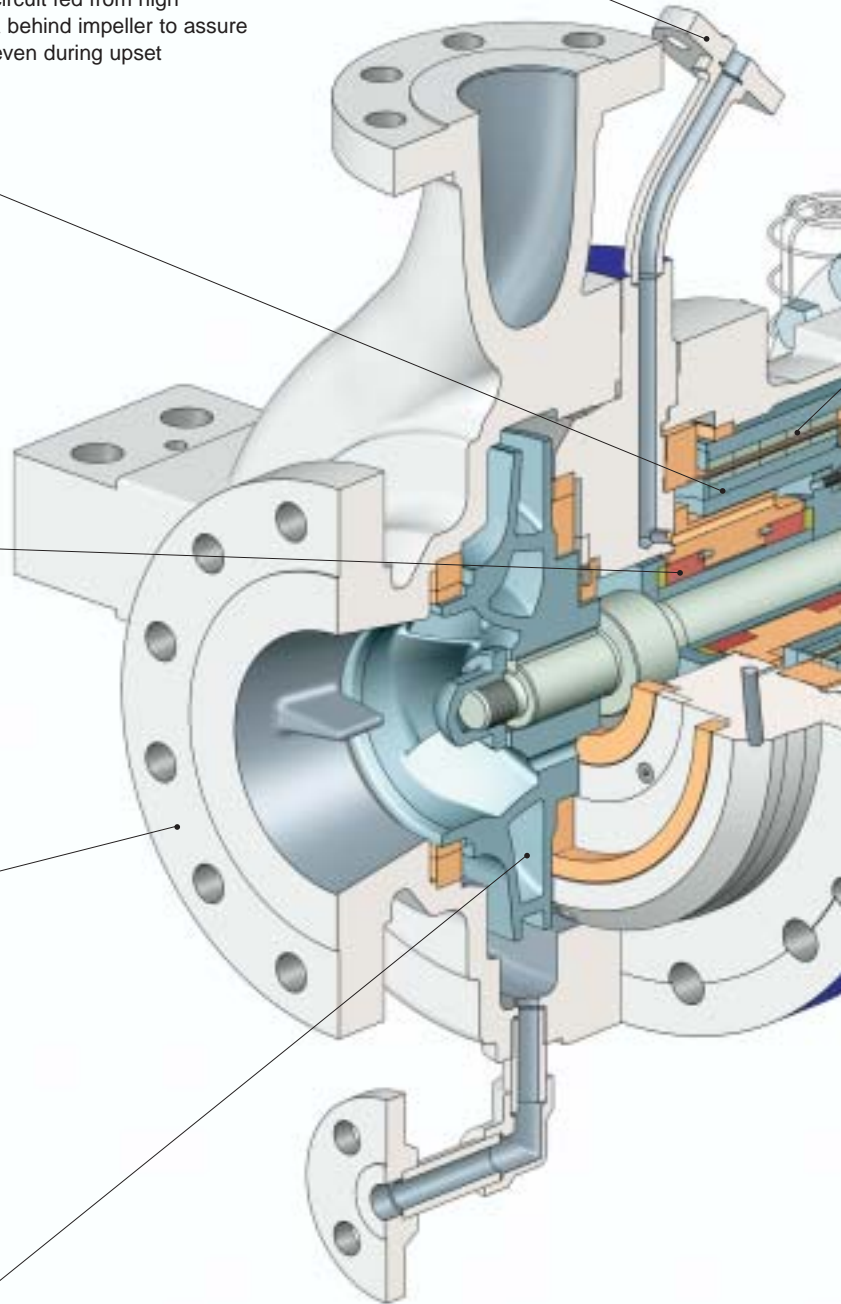

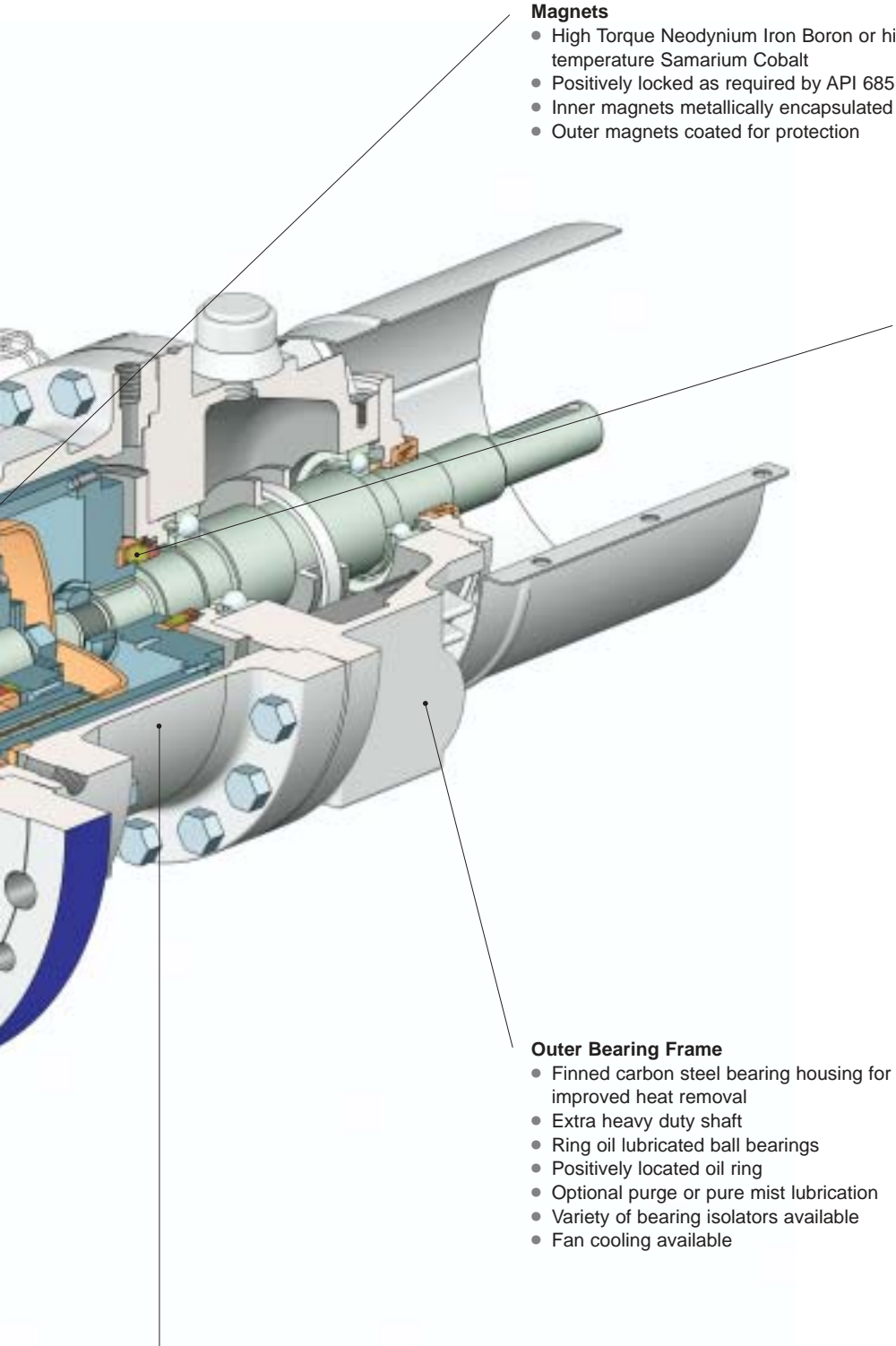

**Magnets**

- High Torque Neodymium Iron Boron or high temperature Samarium Cobalt
- Positively locked as required by API 685
- Inner magnets metallurgically encapsulated for protection
- Outer magnets coated for protection

**Safety Seal**

- Dry running gas seal on secondary containment closes on rise in pressure
- No maintenance necessary

**Typical Instrumentation Available**

- Current Sensor
- Containment shell temperature RTD
- Flush temperature RTD
- Liquid or vapor sensors
- Vibration transducers or switches

**Outer Bearing Frame**

- Finned carbon steel bearing housing for improved heat removal
- Extra heavy duty shaft
- Ring oil lubricated ball bearings
- Positively located oil ring
- Optional purge or pure mist lubrication
- Variety of bearing isolators available
- Fan cooling available

**Secondary Containment**

- Carbon Steel - designed and hydrotested for full discharge pressure
- Rub ring incorporated to prevent outer rotor contact with containment shell
- Interior fully coated to prevent rusting

# Performance Range

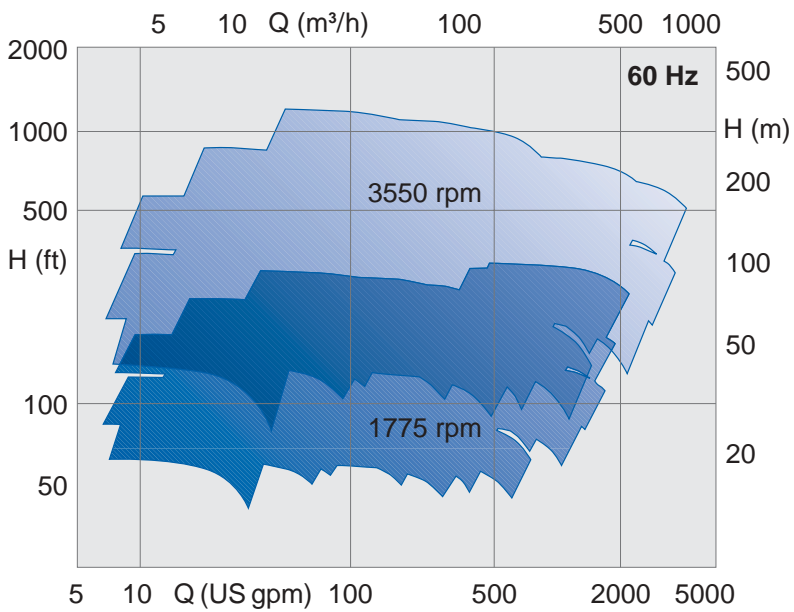
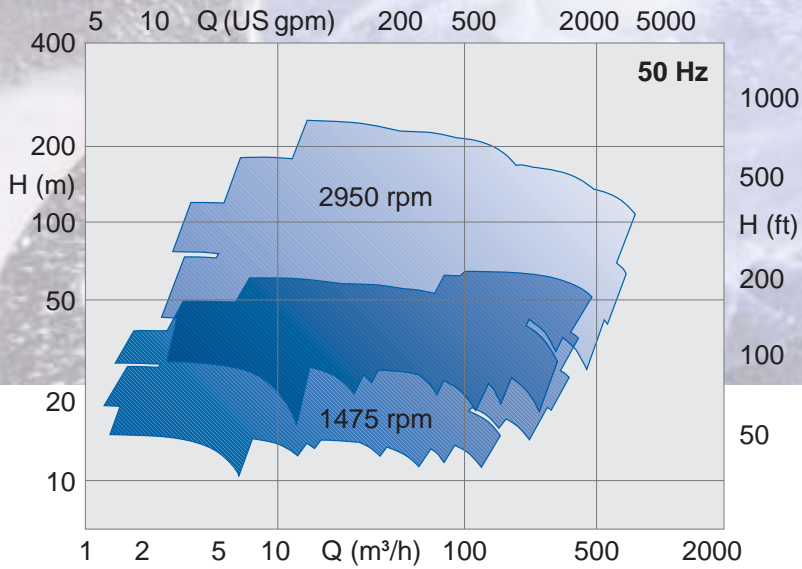

# Operating Data

	OHM	
Pump Sizes	25mm to 200mm	1 to 8 inches
Capacities	up to 700 m³/h	up to 3,100 usgpm
Heads	up to 330 m	up to 1,100 feet
Pressures	up to 52 bar	up to 740 psi
Temperatures	up to +250°C	up to +480°F



## Your Global Partner

Sulzer operates over 20 test facilities world-wide. Our facilities are suitable for horizontal or vertical, open pit, high flow rate/high energy and multiphase testing. We have the ability to perform tests at 50 & 60Hz and, depending on the site, are able to operate using diesel engines, gas engines and gas turbines in addition to conventional electric motors.

A specialty of Sulzer is the ability to fully string test large high-energy pumps to prove the pump package as a whole to our customers. This ability is particularly important for critical offshore applications where on site correction is both expensive and time consuming.

## Customer Support Service

Through our worldwide network of over 50 service centers we provide our customers with a full range of services for pumps and other associated equipment. Local 24 hours a day, 7 days a week customer service backed up by our service groups' global solutions, concept development and support team.

Applying our unique combination of experience and expertise, we are consistently able to deliver high quality, value added rotating equipment support. Furthermore, we can also design, deliver and fit high integrity components for non-Sulzer machinery using our in-house re-engineering specialists.

## Sulzer Customer Alliances

Sulzer Pumps' business strategy is simply to work closely with our partners to gain an understanding of their requirements and expectations, and provide products and services which meet those expectations better than anyone else. We can look back on 10 years of alliance experience.

Our customer alliance agreements are key to our strategy and represent a mutual long term commitment for the purpose of achieving world class pumping system life cycle cost by maximizing the effectiveness of our Partner's and Sulzer's resources. Sulzer currently has agreements with many of the major oil companies focusing on solving problems and simplifying work processes.

- Divisional Headquarters
- Manufacturing facilities
- Customer Support Service Centre
- Sales Office





Check our worldwide offices at  
**[www.sulzerpumps.com](http://www.sulzerpumps.com)**  
or Email us at [hpi.pumps@sulzer.com](mailto:hpi.pumps@sulzer.com)