



SULZER

Sulzer Pumps for Tapioca Starch Applications

**The
Heart
of Your
Process**



Sulzer Pumps at Your Service

AHLSTAR™ APP/APT*

The standard process pumps are designed according to ISO 5199/ISO 2858 standards for all normal pumping applications for clean, abrasive or corrosive liquids and also for liquids containing fibres.



AHLSTAR™ ASP/AST

Self priming gas removal pumps enable efficient and trouble-free pumping of liquids containing gas up to 70% or when self priming pumps are needed.



AHLSTAR™ WPP/WPT

Wear resistant pumps are designed for applications where durability is essential, like pumping both abrasive and corrosive liquids and slurries containing particles.



AHLSTAR™ NPP/NPT

Wear resistant pumps are designed for applications where durability is essential, like pumping both abrasive and corrosive liquids and slurries containing particles.



AHLSTAR™ WSP/WST

Wear resistant self priming gas removal pumps for self priming applications and pumping of gas containing corrosive and abrasive liquids.



SALOMIX™ LV Agitator

The slow rotating top entry agitators with AF/AFX -paddles for efficient starch handling. The LV agitators are available for the most storage and production tank applications.

CPT Advantage Process Pumps

series is designed according to ANSI/ASME B73.1 M standards for all normal pumping applications for clean, abrasive or corrosive liquids and also for liquids containing fibers.

** P and T versions refer to metric and inch measures*



Advanced Pumping Solutions for the Starch Industry

Sulzer Pumps has made hundreds of pumps that are running in demanding applications in starch and starch based sweetener industries. Our high quality products and deep understanding of starch processes generate reliable pumping solutions to meet the needs of our customers.

A problem frequently faced by the starch industry is pumping liquids that are liable to foam. This special feature of starch processes arises partly because of the protein content of the pumped liquids and partly because the different raw material components are separated mechanically. The AHLSTAR™ ASP Self Priming Gas Removal Pump is the perfect solution to pump these foamy liquids, and at the same time remove significant

amounts of the troublesome air to help with downstream processing.

Other pumping solutions for the starch industry from Sulzer Pumps are AHLSTAR™ APP Process Pumps and CPT Advantage Process Pumps.

Both can be equipped with the unique Dynamic Seal for leakage-free shaft sealing. In the Dynamic Seal there are no narrow areas corresponding to the seal faces in mechanical seals, and no wearing parts. No sealing water and thus no sealing water systems are needed for the Dynamic Seal. Until now, conventional mechanical seals and stuffing boxes have been the most maintenance intensive components of centrifugal pumps used in the starch industry. Thanks to the Dynamic Seal, mechanical wear, leakage

and the need for sealing liquid have been practically eliminated.

Sulzer Pumps' AHLSTAR™ series is designed according to ISO 5199 standards. Our CPT Advantage Process Pumps series is designed according to ANSI/ASME B73.1 M standards. Both pump series are designed for continuous operation in process industries.

Let's make the best out of your process pumping!

Washing of Tapioca

Special features: abrasion

For waters containing tapioca

The AHLSTAR™ NPP/NPT non-clogging process pump with

- closed impeller
- corrosion and wear resistant stainless steel ASTM A890 3A
- unique dynamic shaft seal

For washing waters containing sand and mud

The AHLSTAR™ WPP/WPT wear and corrosion resistant process pump with

- wear-resistant closed impeller
- corrosion and wear resistant chromium iron ASTM A532 IIIA
- unique dynamic shaft seal

For clean and clarified waters

The AHLSTARt APP/APT process pump with

- high efficiency, low NPSHr closed impeller
- corrosion and wear resistant stainless steel ASTM A890 3A
- unique dynamic shaft seal

or

The CPT advantage process pump (ANSI dimensional pump) with

- high efficiency, low NPSHr open impeller
- corrosion and wear resistant stainless steel ASTM A890 3A
- unique dynamic shaft seal

For dirty sump waters

The AHLSTAR™ WSP/WST wear resistant self priming gas removal pump with

- vortex impeller
- corrosion and wear resistant chromium iron ASTM A532 IIIA
- internal vacuum system



Tapioca Rasing

Special features: gas

For foaming rasped tapioca mixture

The AHLSTAR™ ASP/AST self priming gas removal process pump with

- high efficiency, low NPSHr open impeller
- corrosion and wear resistant stainless steel ASTM A890 3A
- internal vacuum system

The SALOMIX™ LV -agitator with

- versatile gear drive
- high axial flow paddle
- different seal options
- SS2343 material for parts in contact with liquid

Fiber Pulp Separation

For foaming starch and fruit juice

The AHLSTAR™ ASP/AST self priming gas removal process pump with

- high efficiency, low NPSHr open impeller
- corrosion and wear resistant stainless steel ASTM A890 3A
- internal vacuum system

Fruit Juice Separation

Special features: gas

For pumping between hydrocyclone stages

The AHLSTAR™ APP/APT process pump with

- high efficiency, low NPSHr closed impeller
- corrosion and wear resistant stainless steel ASTM A890 3A
- unique dynamic shaft seal

or

The CPT Advantage process pump (ANSI dimensional pump) with

- high efficiency, low NPSHr open impeller
- corrosion and wear resistant stainless steel ASTM A890 3A
- unique dynamic shaft seal





For gas containing starch and fruit juices

The AHLSTAR™ ASP/AST self priming gas removal process pump with

- high efficiency, low NPSHr open impeller
- corrosion and wear resistant stainless steel ASTM A890 3A
- internal vacuum system

The SALOMIX™ LV -agitator with

- versatile gear drive
- high axial flow paddle
- different seal options
- SS2343 material for parts in contact with liquid

Starch Washing

For starch and washing liquids

The AHLSTAR™ APP/APT process pump with

- high efficiency, low NPSHr closed impeller
- corrosion and wear resistant stainless steel ASTM A890 3A
- unique dynamic shaft seal

or

The CPT Advantage process pump (ANSI dimensional pump) with

- high efficiency, low NPSHr open impeller
- corrosion and wear resistant stainless steel ASTM A890 3A
- unique dynamic shaft seal

The SALOMIX™ LV -agitator with

- versatile gear drive
- high axial flow paddle
- different seal options
- SS2343 material for parts in contact with liquid



Tapioca Starch Process

General Flowsheets

Tapioca Washing

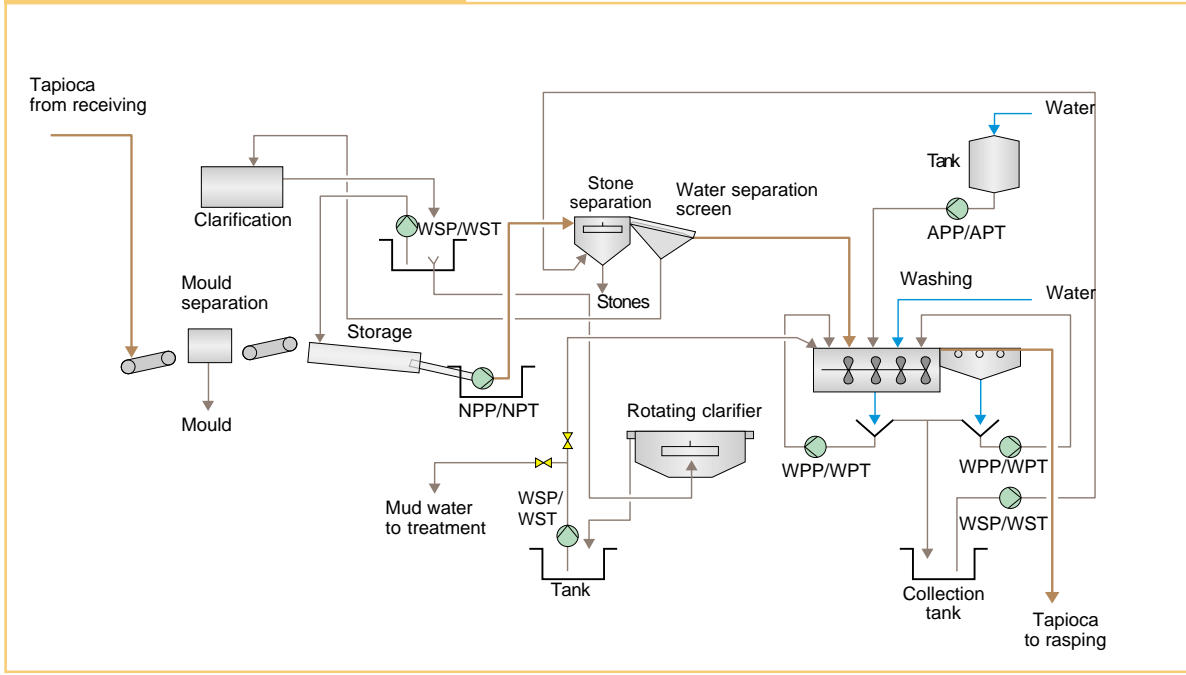

Tapioca Rasping

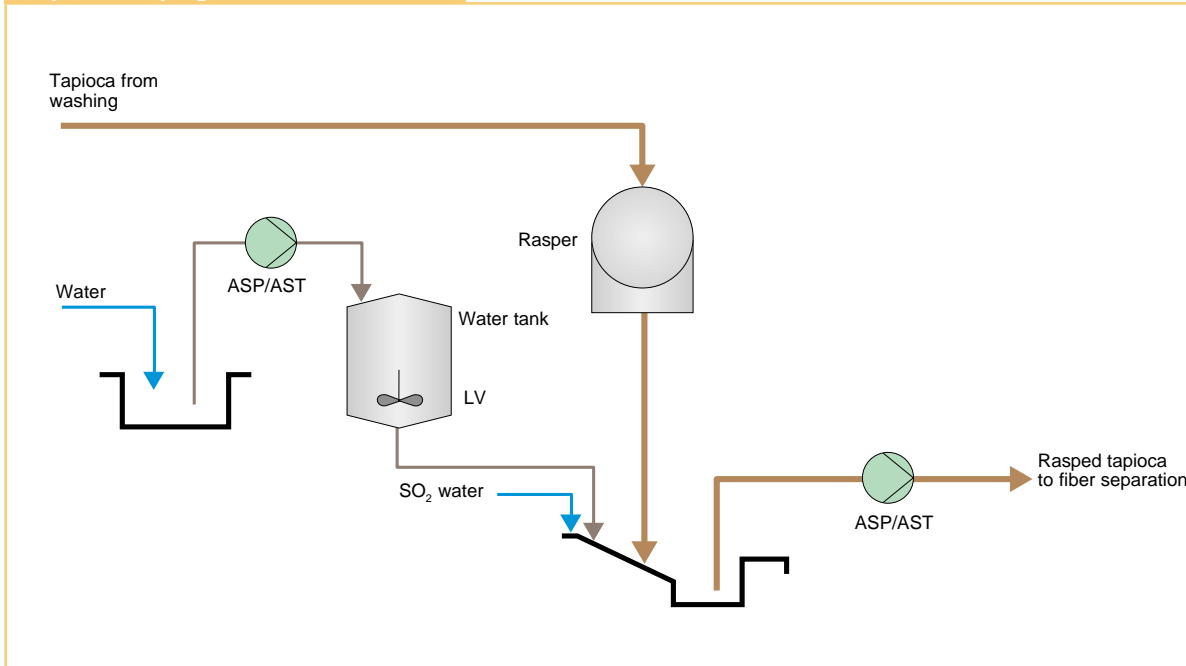

Tapioca Fiber Separation

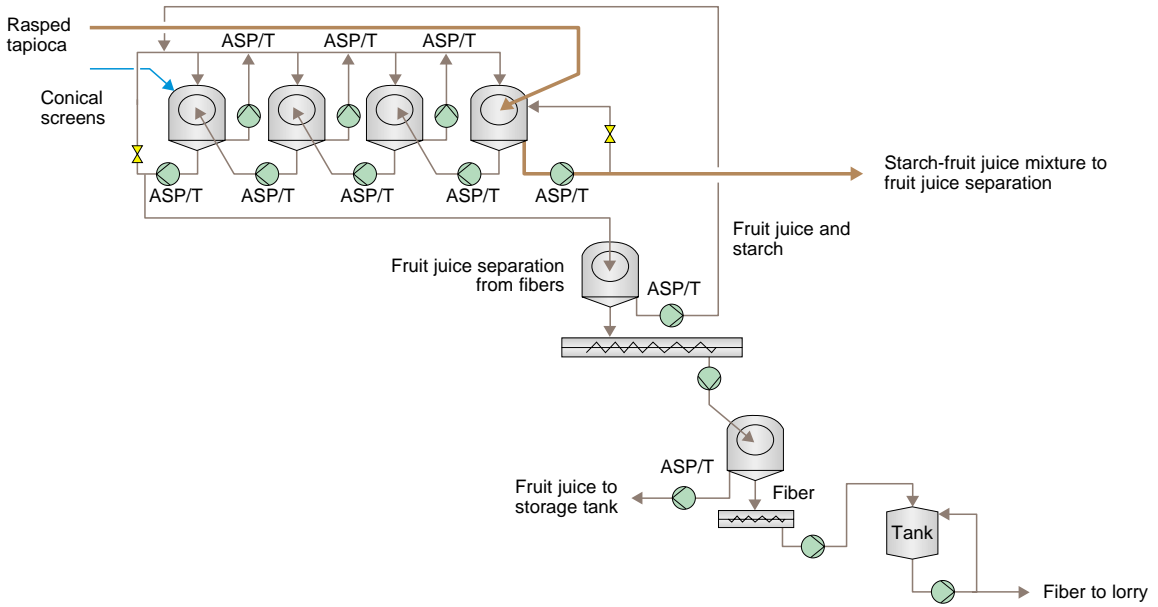

Fruit Juice Separation

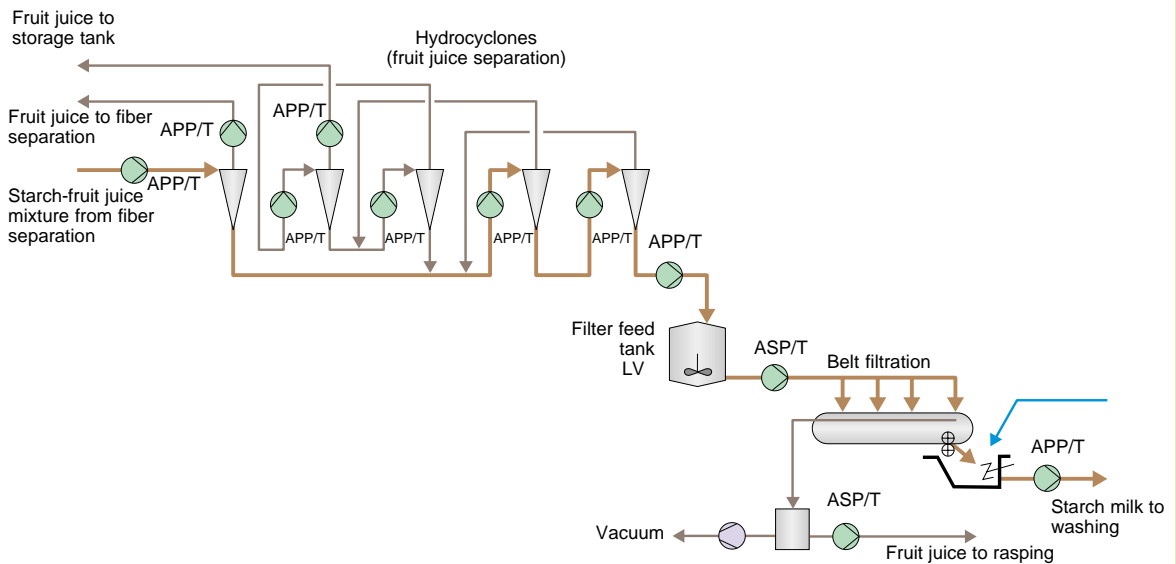

Tapioca Starch Washing

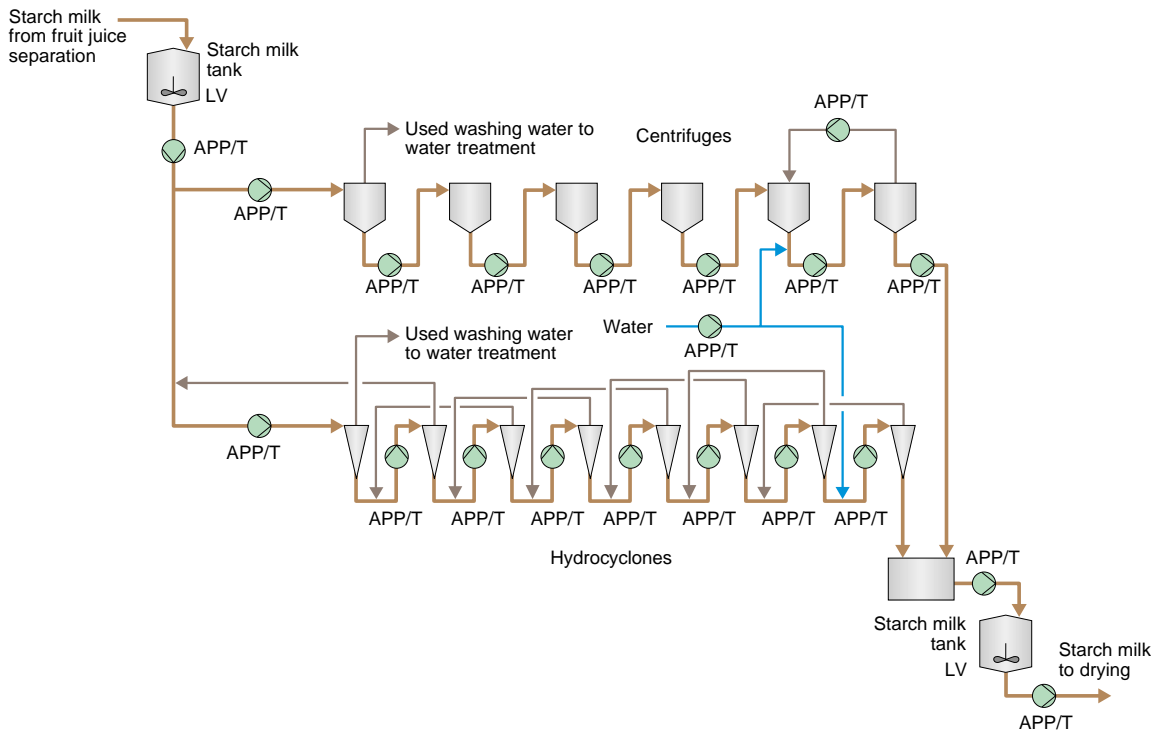

Tapioca Starch Drying

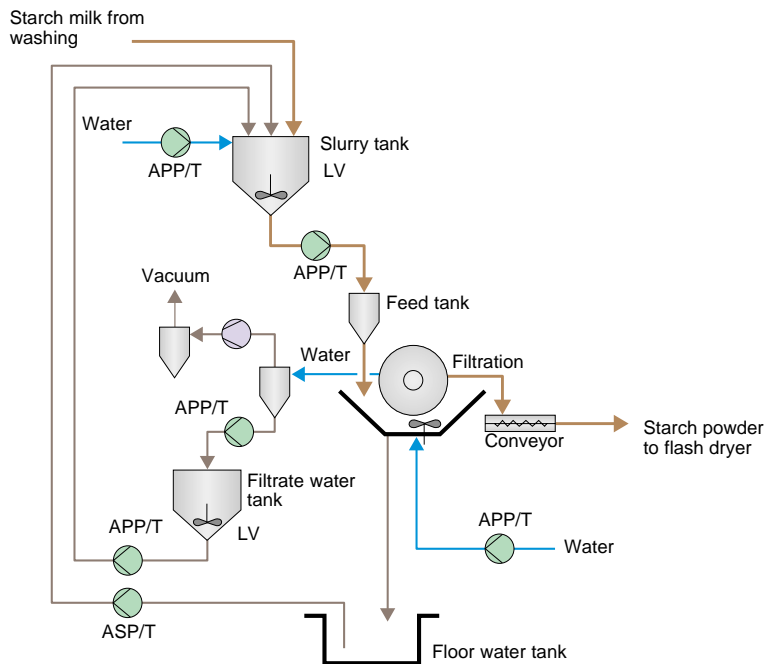



Check our worldwide offices at
www.sulzerpumps.com