

Helical Twisted Roots Pumps

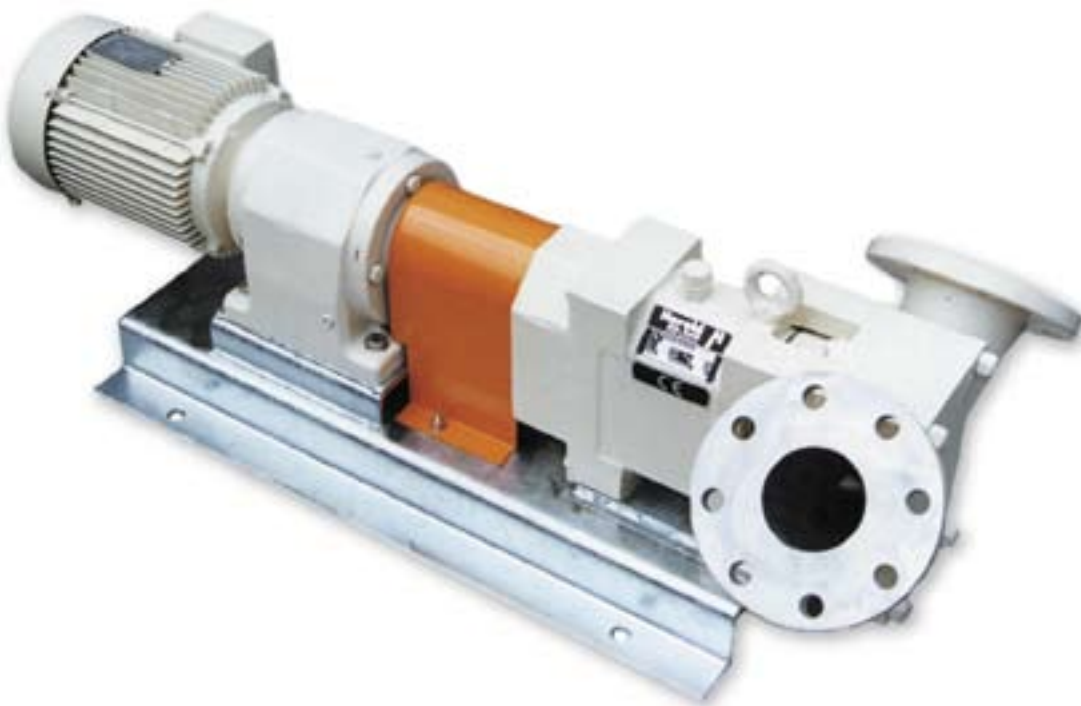

Sulzer Pumps – Striving to Serve You Better

Sulzer Pumps is a leading global supplier of reliable products and innovative pumping solutions for end users. Our active research and development, detailed process and application knowledge together with a comprehensive understanding of market demands keeps us consistently at the leading edge of technical development.

Our global network of modern manufacturing and packaging facilities together with sales offices, service centers and representatives located close to major markets provide fast responses to customer needs.

Sulzer Pumps is active serving business partners in the following industries:

- Oil & Gas
- Hydrocarbon Processing
- Pulp & Paper
- Power Generation
- Food, Metals & Fertilizers
- Water & Wastewater

Helical Twisted Pumps for Media with High Viscosity, Shear Sensitive Media or Liquids Containing Solids

Outstanding Features of the Pumps

- Rotors do not touch each other or the casing
- Minimum wear, long lifetime, reliable operation
- Tolerant against short periods of running dry
- Possibility of switching pumping direction
- Volumetric delivery directly proportional to rpm
- Continuous flow
- Wide range of applications
- Pumps media of highest viscosity (over 800.000 cP)
- Pumps liquids mixed with crystals or solids
- Crystals or solids are not damaged in pumping
- Gentle mixing effect on pumped medium
- High efficiency
- Pump fulfills CIP requirements

Design Advantages

- Rugged construction
- Easy cleaning
- Designed for ease of inspection and maintenance
- Choice of different shaft seals
- Rotors are helical twisted by 90°
- Modular construction
- Construction can be changed for higher pressure
- Construction can be adapted for higher temperature

The Advantages of Twisted Helical Wendelkolben® Rotors

- Continuous flow with absolute constant volume
- Lowest pulsation rate worldwide
- Smooth and gentle treatment of the medium to be pumped
- Exceptionally low noise level
- Tremendous reduction in power consumption

Global sales and marketing for sugar, starch, sweetener and ethanol industry by Sulzer Pumps.

Developed, patented and manufactured by Herold & Co. GmbH, Gefrees, Germany.





Typical Applications

Sugar Industry

Crystal suspensions, sucrose solutions, thick juices, massecoites, molasses, magmas.

Starch Industry

Gluten, dextrose anhydride, dextrose monohydrate.

Ethanol, Liquor and Beverage Industry

Mash, yeast, condiments, fruit purees, fruit juice concentrates.

Sweets and Candies

Jelly, gelatin, ice cream, chocolate, cacao butter, peanut butter, butter fat, starch gum.

Other Food Industry

Stewed fruit, ketchup, tomato paste, mustard, emulsified cream and gravy, marinade, salad dressing, jelly, jam, marmalade, plum-jam, desserts, pulp, syrup, soup, pap, stew, baby food, mash, pudding, mushrooms, cranberries, cabbage etc.

Example of Herold's Helical Twisted Roots Pump in a Sugar Factory

Medium:	Massecoite
Temperature:	55° C
Density:	1450 kg/m ³
Dry substance:	91%
Pump type:	01.035
Pump rpm:	145 1/min
Flow:	27 m ³ /h
Pressure:	6,0 bar
Drive:	Gear motor 13,5 kW



Schematic of the Pumping Principle

1. When the helical twisted rotors are rotated a vacuum is created, which draws liquid smoothly and without interruption into the pumping chamber.

2. By further rotation the liquid is locked in between the rotors and the rotor housing.
3. Liquid is transported to discharge side.

4. Liquid is discharged, smoothly and with the lowest pulsation worldwide.

When changing the direction of rotation the flow is reversed.

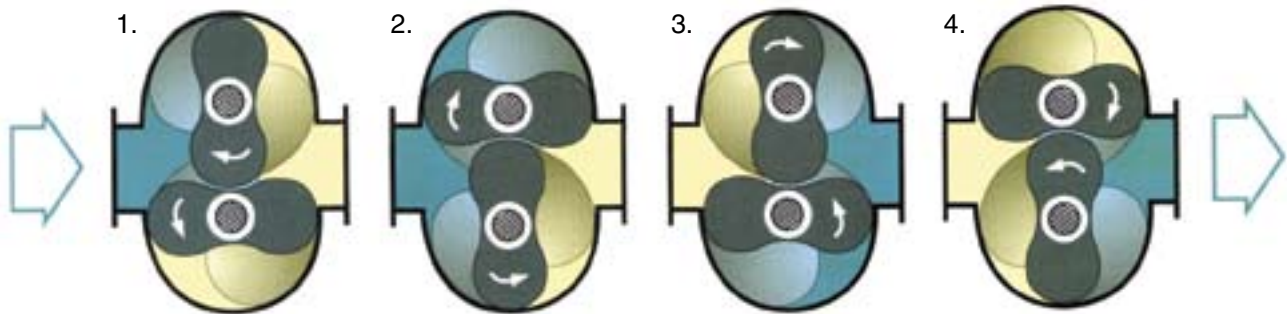

Main Features

9 pump sizes

- Pressure up to 9 bar/128 psi (higher pressure on request)
- Vol. delivery up to 180 m³/h

Installation

- Horizontal (standard)
- Vertical (on request)

Materials in contact with the medium

- Ni-resist
- Stainless steel

O-rings

- NBR
- Viton (other materials on request)

Surface finishing

- Painted

Pipe connections

- Flanges
- Milkpipe threads
- Sterile threads

Accessories

- Quench-tank
- Heating/cooling plate
- Basic frame
- Height adjustable frame
- Portable frame
- Current reverser
- Frequency exchanger

Drive

- Gear motor
- Variable speed gear motor
- Standard clutch
- Safety clutch



Shaft Sealing

Mechanical Seal with Quench

For the sugar industry special mechanical seals were developed which are strain free, independent of direction of rotation and spring suspended on the atmosphere side of the seal (dry). In the standard version the O-rings are made of Viton and the mechanical seal surfaces are made of tungsten carbide. The mechanical seals are lubricated and cooled by a non-pressurized quench system. The secondary seal is also a mechanical seal.

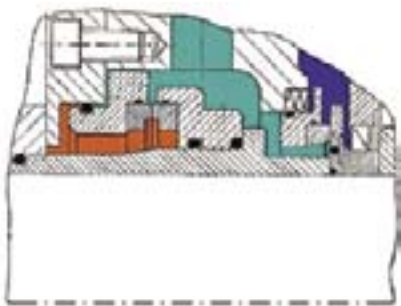

Single Mechanical Seal

This mechanical seal is strain free, independent of direction of rotation and has enclosed springs. In the standard version the O-rings are made of Viton and the mechanical seal surfaces are made of silicone carbide. A non-pressurized quench system can be supplied as an optional accessory.

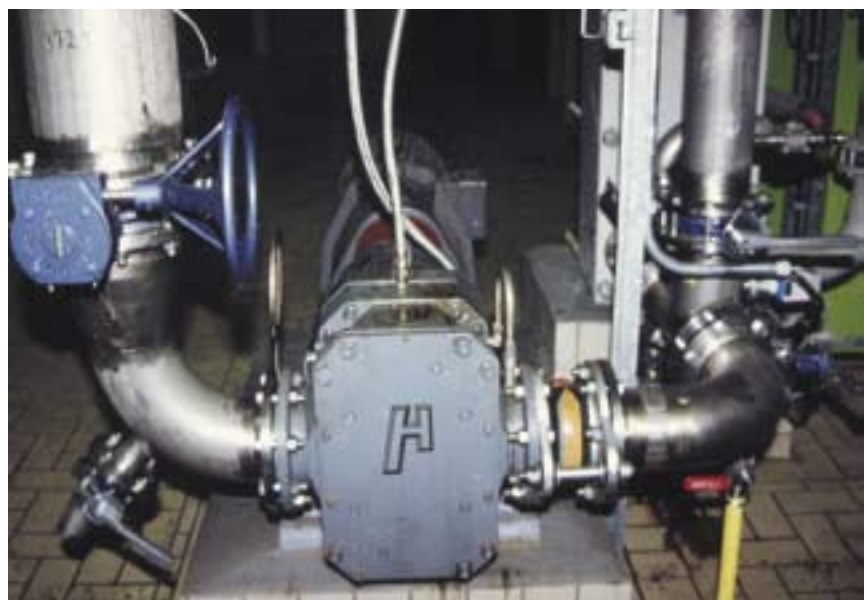
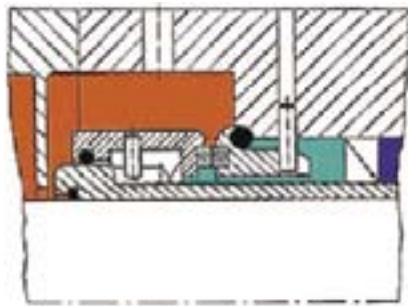

Performance Data

Type	Vol. delivery m ³ /h		Pressure max.bar	Rpm max. 1/min	mm	Flange ID in
	min.	max.				inch
01.003	1	7	9	400	50	1.97
01.003 V	1	7	9	400	80/45°	3.15/45°
01.005	2	12	9	400	50	1.97
01.005 V	2	12	9	400	80/45°	3.15/45°
01.010	4	24	8	400	100	3.94
01.010 V	4	24	8	400	150/45°	5.91/45°
01.014	6	34	7	400	100	3.94
01.014 V	6	34	7	400	150/45°	5.91/45°
01.028	12	68	8	400	125	4.92
01.028 V	12	68	8	400	200/45°	7.87/45°
01.035	15	84	7	400	125	4.92
01.035 V	15	84	7	400	200/45°	7.87/45°
01.050	18	105	8	350	150	5.91
01.050 V	18	105	8	350	250/45°	9.84/45°
01.075	27	135	7	300	200	7.87
01.075 V	27	135	7	300	300/45°	11.81/45°
01.100	36	180	6	300	200	7.87
01.100 V	36	180	6	300	300/45°	11.81/45°

Size code:

Example 01.005 = 0.5 liter / 0.13 US gal / 0.11 Imp gal / vol. delivery / rpm

01.100 = 10.0 liter / 2.64 US gal / 2.20 Imp gal / vol.delivery / rpm

06.028 = 2.8 liter / 0.74 US gal / 0.62 Imp gal / vol.delivery / rpm

1m³ (1000 l) = 264 US gal = 220 Imp gal = 35.31 ft³

1 bar = 14.2 psi

All parts which are in touch with the media are Ni-resist or stainless steel material.

Maximum rpm in relation to viscosity of the media

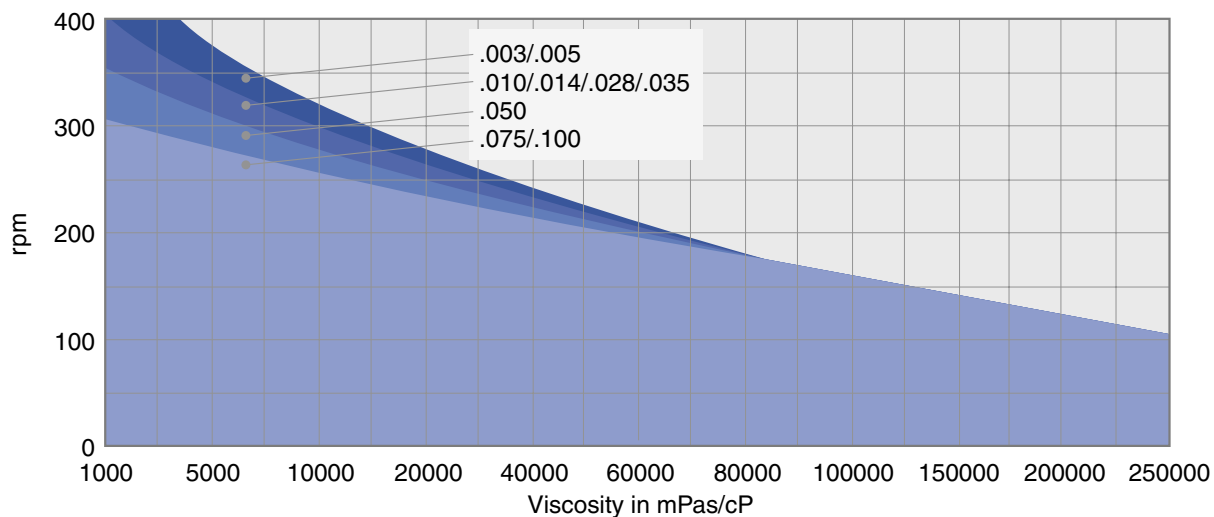

Performance Data

Type	Vol. delivery m ³ /h min.	Vol. delivery m ³ /h max.	Pressure max.bar	Rpm max. 1/min	Milkpipe thread ID in mm	Milkpipe thread ID in inch
06.003	1	7	9	400	50	1.97
06.003 V	1	7	9	400	80/45°	3.15/45°
06.005	2	12	9	400	50	1.97
06.005 V	2	12	9	400	80/45°	3.15/45°
06.010	4	24	8	400	80	1.97
06.014	6	34	7	400	80	1.97
06.028	12	68	8	400	100	3.94
06.035	15	84	7	400	100	3.94

Type 06 for the food industry in American 3A standard available

All parts which are in touch with the media are polished stainless steel material.

Sectional Drawings

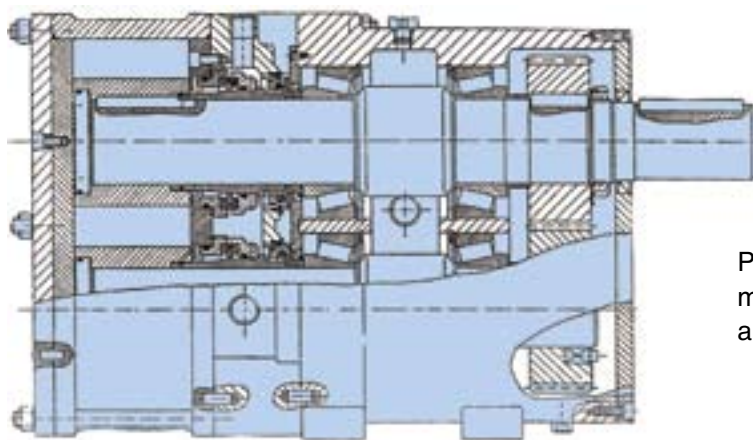

Pump type 0.1 with mechanical seals and quench

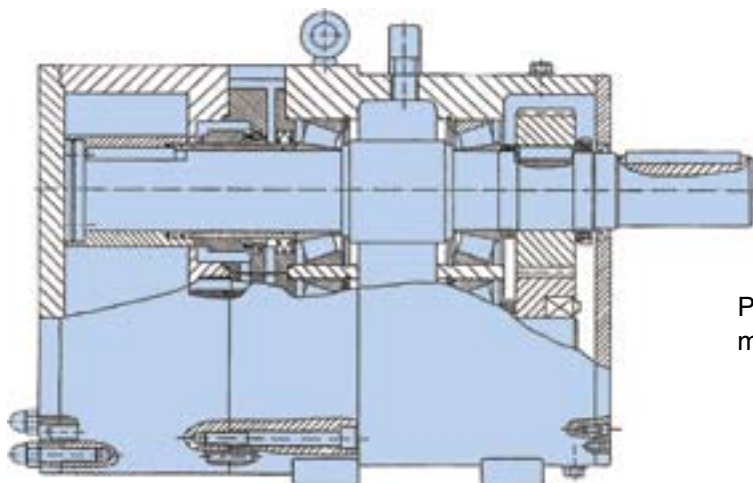

Pump type 0.6 with mechanical seals

Dimensions of Standard Design

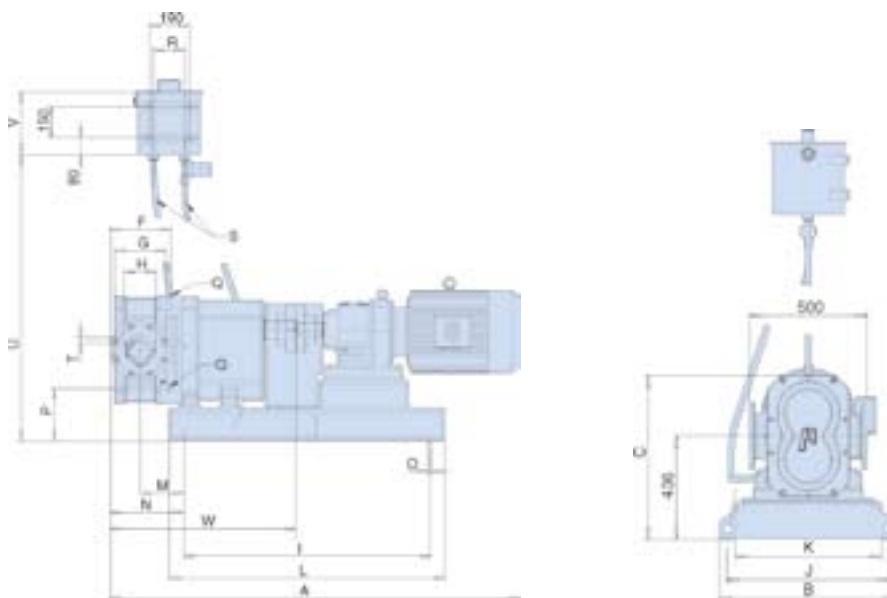

Pump type	02.003/02.005		01.010/01.014		01.028/01.035		01.050		01.075/01.100	
Elect. drive	R 72 DT 100R		802 DV 132/S4		R 802 DV 132/M4		R 82 DV 160/M4		R 102 DV 180/L4	
Weight	180 kg		420 kg		685 kg		1025 kg		1565 kg	
Dimension	mm	inch	mm	inch	mm	inch	mm	inch	mm	inch
A	1110	43.70	1140	56.69	1565	61.61	1740	68.50	2150	84.65
B	400	15.75	650	25.59	790	31.10	750	29.53	800	31.50
C	330	12.99	520	20.47	630	24.80	655	25.79	860	33.86
D	240	9.45	350	13.78	420	16.54	500	19.69	600	23.62
E	214	8.43	280	11.02	347	13.66	395	15.55	482	18.98
F	165	6.50	220	8.66	250	9.84	285	11.22	340	13.39
G	125	4.92	180	7.09	210	8.27	240	9.45	295	11.61
H	50	1.97	100	3.94	125	4.92	150	5.91	200	7.87
I	650	25.59	600	23.62	700	27.56	1000	39.37	1000	39.37
J	350	13.78	580	22.83	620	24.41	680	26.77	750	29.53
K	300	11.81	500	19.69	540	21.26	600	23.62	650	25.59
L	850	33.46	930	36.61	1115	43.90	1350	53.15	1300	51.18
M	116	4.57	245	9.65	303	11.93	290	11.42	298	11.73
N	161	6.34	355	13.98	428	16.85	435	17.13	468	18.43
O	18	0.71	23	0.91	26	1.02	26	1.02	26	1.02
P	151	5.94	163	6.42	215	8.46	250	3.88	225	8.86
Q	G1/4"	G1/4"	G3/4"	G3/4"	G3/4"	G3/4"	G3/4"	G3/4"	G3/4"	G3/4"
R	150	5.91	150	5.91	150	5.91	150	5.91	150	5.91
S	18	0.71	18	0.71	18	0.71	18	0.71	18	0.71
T	4 x 18	4 x 0.71	8 x 18	8 x 0.71	8 x 18	8 x 0.71	8 x 23	8 x 0.91	12 x 23	12 x 0.91
U	1300	51.18	1950	76.77	1950	76.77	2170	85.43	2100	82.6
V	293	11.54	300	11.81	300	11.81	300	11.81	400	15.75
W	489	19.25	668	26.30	773	30.43	886	34.88	1051	41.38

Dimensions of V Design

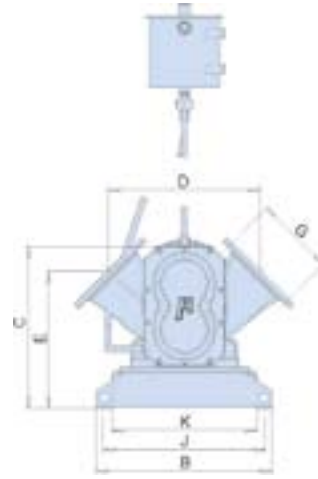
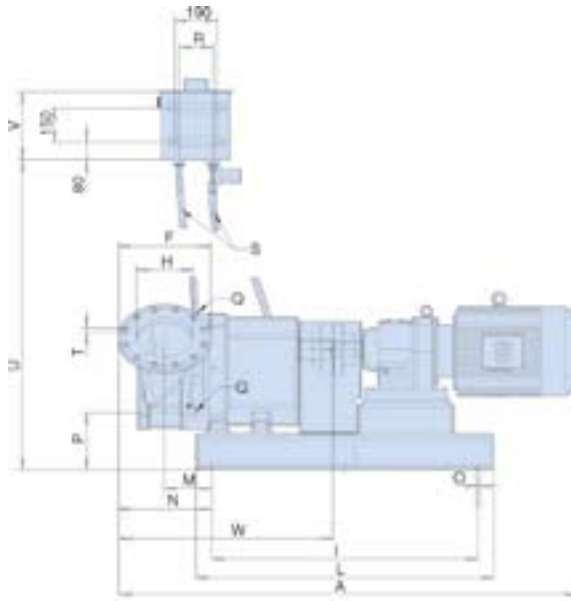

Pump type	02.003V/02.005V		01.010V/01.014V		01.028V/01.035V		01.050V		01.075V/01.100V	
Elect. drive	R 72 DT 100		R 802 DV 132/S4		R 802 DV 132/M4		R82 DV 160/M4		R102 DV 180/L4	
Weight	190 kg		440 kg		710 kg		1055 kg		1600 kg	
Dimension	mm	inch	mm	inch	mm	inch	mm	inch	mm	inch
A	1130	44.49	1472	57.95	1610	63.39	1800	70.87	2210	87.01
B	400	15.75	650	25.59	790	31.10	750	29.53	800	31.50
C	330	12.99	520	20.47	630	24.80	655	25.79	860	33.86
D	330	12.99	430	16.93	520	20.47	650	25.60	736	28.98
E	312	12.28	400	15.75	487	19.17	547	21.54	644	25.35
F	200	7.87	285	11.22	340	13.39	405	15.94	460	18.11
G	160	6.30	240	9.45	295	11.61	355	13.98	410	16.14
H	80	3.15	150	5.91	200	7.87	250	9.84	300	11.81
I	650	25.59	600	23.62	700	27.56	1000	39.37	1000	39.37
J	350	13.78	580	22.83	620	24.41	680	26.77	750	29.53
K	300	11.81	500	19.69	540	21.26	600	23.62	650	25.59
L	850	33.46	930	36.61	1115	43.90	1350	53.15	1300	53.15
M	116	4.57	245	9.65	303	11.93	290	11.42	298	11.73
N	179	7.05	387	15.24	480	18.90	495	19.49	528	20.79
O	18	0.71	23	0.91	26	1.02	26	1.02	26	1.02
P	151	5.94	163	6.42	215	8.46	250	9.84	225	8.86
Q	G1/4"	G1/4"	G3/4"	G3/4"	G3/4"	G3/4"	G3/4"	G3/4"	G3/4"	G3/4"
R	150	5.91	150	5.91	150	5.91	150	5.91	150	5.91
S	18	0.71	18	0.71	18	0.71	18	0.71	18	0.71
T	8 x 18	8 x 0.71	8 x 23	8 x 0.91	12 x 23	8 x 0.91	12 x 27	12 x 1.06	12 x 27	12 x 1.06
U	1300	51.18	1950	76.77	1950	76.77	2170	85.43	2100	82.68
V	293	11.54	300	11.81	300	11.81	300	11.81	400	15.75
W	507	19.96	700	27.56	818	32.20	946	37.24	1111	43.75



Check our worldwide offices at
www.sulzerpumps.com