



SULZER

Sulzer Pumps for Fermented Ethanol Applications

The **Heart**
of Your
Process





Sulzer Pumps at Your Service

AHLSTAR™ APP/APT* standard process pumps are designed according to ISO 5199/ISO 2858 standards for all normal pumping applications for clean, abrasive or corrosive liquids and also for liquids containing fibers.



AHLSTAR™ WPP/WPT wear resistant pumps are designed for applications where durability is essential, like pumping both abrasive and corrosive liquids and slurries containing particles.



AHLSTAR™ ASP/AST self priming gas removal pumps enable efficient and trouble-free pumping of liquids containing gas up to 70% or when self priming pumps are needed.



ADVANTAGE CPT chemical process pumps series is designed according to ANSI/ASME B73.1 M standards for all normal pumping applications for clean, abrasive or corrosive liquids and also for liquids containing fibers.



SALOMIX™ SLG-gear-driven Agitators provides the highest efficiency in all process conditions by combining the well-known SALOMIX MX4 fourbladed propellers and an effective conical body shape

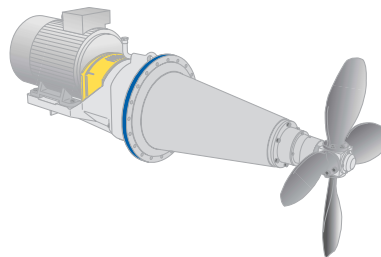

SALOMIX™ LV Agitator is the slow rotating top entry agitators with AF/AFX -paddles for efficient starch handling. The LV agitators are available for the most storage and production tank applications.

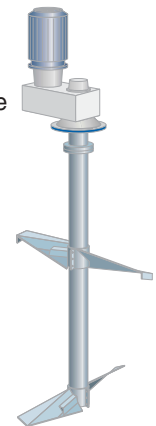

PUMPS FOR OTHER UTILITIES

We also have wide range of pumps for applications in water transport, boiler feed and dewatering.

* P and T versions refer to metric and inch measures



Advanced Pumping Solutions for the Ethanol Industry

Research and Development have always played a major role at Sulzer Pumps. Our main target is to always meet or exceed the customer's requirements. Therefore, we have studied ethanol process pumping demands, to be able to choose the right pump for every application.

Sulzer Pumps' AHLSTAR™ series is designed according to ISO 5199 standards for continuous operation in industrial processes. One key features of this product line is the interchangeability of parts and components. This allows new technology to be easily incorporated into the full range of product offerings.

In ethanol production reliable shaft sealing of pumps is a crucial factor. Sulzer Pumps choose the right seal - whether that means Dynamic seal, single or double mechanical seals, or conventional gland packing - for every specific application in ethanol production. Material selection has a major effect on pumplifetime. The general drive to increase efficiency throughout the process, including the use of one-pump system, makes the selection of every pump and its material more important than ever before.

Let's make the best out of your process pumping!





Starch Conversion and Fermentation

Special features: gas

For starch gelatinization and saccharification

The AHLSTAR™ APP/APT process pumps

- high efficiency, closed and low NPSHr impeller
- corrosion and wear resistant stainless steel ASTM A890 3A
- a unique dynamic shaft seal

The ADVANTAGE CPT chemical process pumps (ANSI dimensional pump) with

- high efficiency, low NPSHr open impeller
- corrosion and wear resistant stainless steel ASTM A890 3A
- a unique dynamic shaft seal

Or

Distillation

Special features: abrasion, high temperature

For sand-containing stillage

The AHLSTAR™ WPP/WPT wear and corrosion resistant process pumps with

- wear resistant closed impeller
- corrosion and wear resistant stainless steel ASTM A890 3A
- mechanical shaft seal

For ethanol and condensates

The AHLSTAR™ APP/APT process pumps with

- high efficiency, low NPSHr closed impeller
- corrosion and wear resistant stainless steel material ASTM A890 3A
- mechanical shaft seal

Or

The ADVANTAGE CPT chemical process pumps (ANSI dimensional pump) with

- high efficiency, low NPSHr open impeller
- corrosion and wear resistant stainless steel ASTM A890 3A
- mechanical shaft seal



Stillage Handling

For waters and condensates

The AHLSTAR™ APP/APT process pumps with

- high efficiency, low NPSHr closed impeller
- corrosion and wear resistant stainless steel material ASTM A890 3A
- mechanical seal for boiling waters and condensates

Or

The ADVANTAGE CPT chemical process pumps (ANSI dimensional pump) with

- high efficiency, low NPSHr open impeller
- corrosion and wear resistant stainless steel ASTM A890 3A
- mechanical shaft seal for boiling waters and condensates

For evaporated syrups

The AHLSTAR™ APP/APT process pumps with

- high efficiency, low NPSHr open impeller
- corrosion and wear resistant stainless steel material ASTM A890 3A
- unique dynamic shaft seal

Or

The ADVANTAGE CPT chemical process pumps (ANSI dimensional pump) with

- high efficiency, low NPSHr open impeller
- corrosion and wear resistant stainless steel ASTM A890 3A
- unique dynamic shaft seal



Other Utilities

Water transport

The B series of vertical line shaft pumps consist of BK, BS and BP ranges. They are primarily used in water lift, transfer and cooling water applications.

AHLSTAR™ NVP/NVT non-clogging vertical pumps are intended for all kinds of hard applications with waste water, slurries or waste stock.

SM/SMN single stage double entry pumps are used across a broad range of industries in liquid transport and transfer applications.

ZPP double suction pumps are designed for applications including cooling and circulating water pumping.

Boiler feed

The HPP/HPT high pressure multi-stage pumps are used for pumping clean or slightly contaminated liquids in high pressure applications in various industries.

The M series of ring section multi-stage pumps consist of MB, MD and ME ranges. A wide range of common hydraulic components and bearing assemblies are used within the 4 standard pressure ranges.



Fermented Ethanol Process

Starch conversion

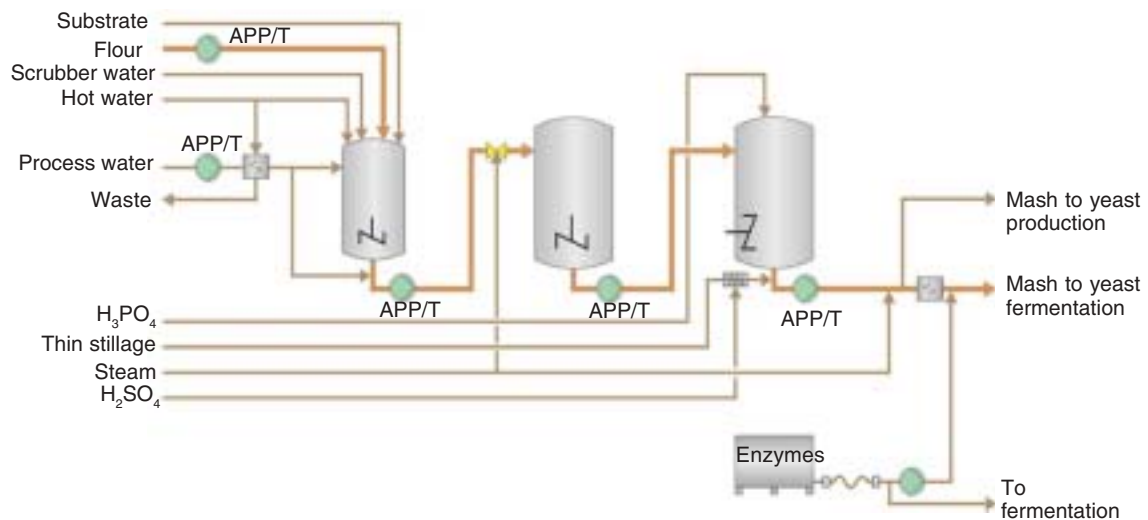

Fermentation

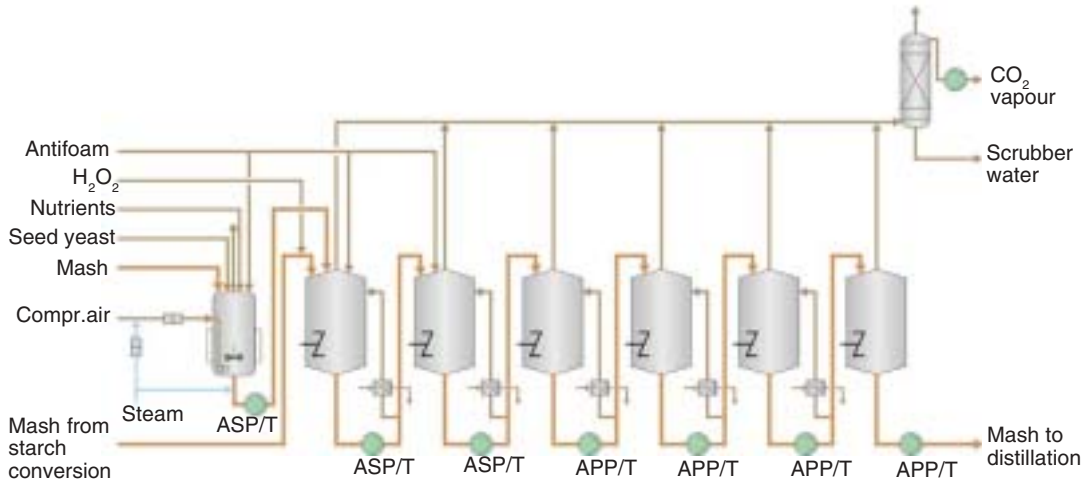

Distillation

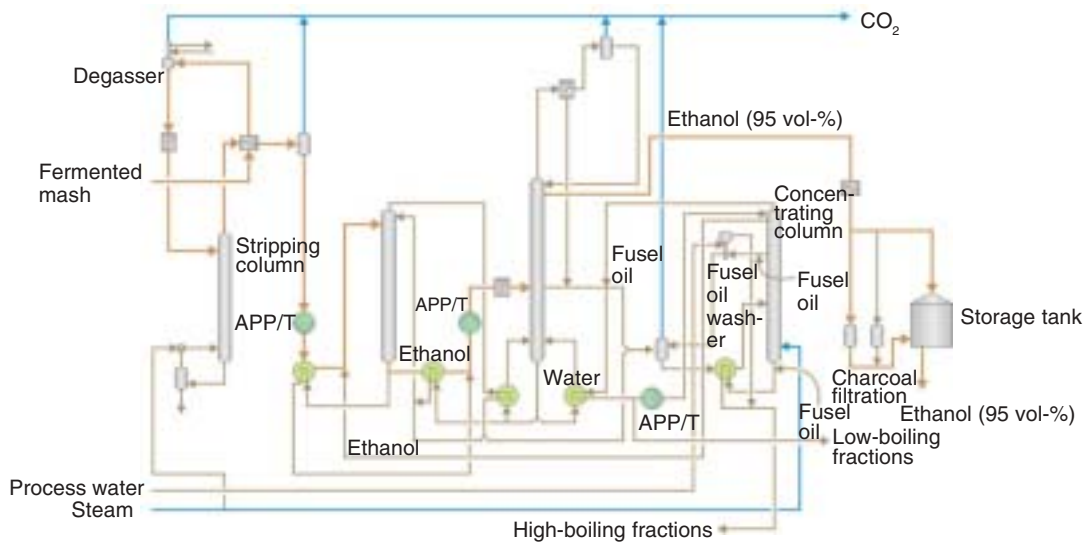

Stillage handling

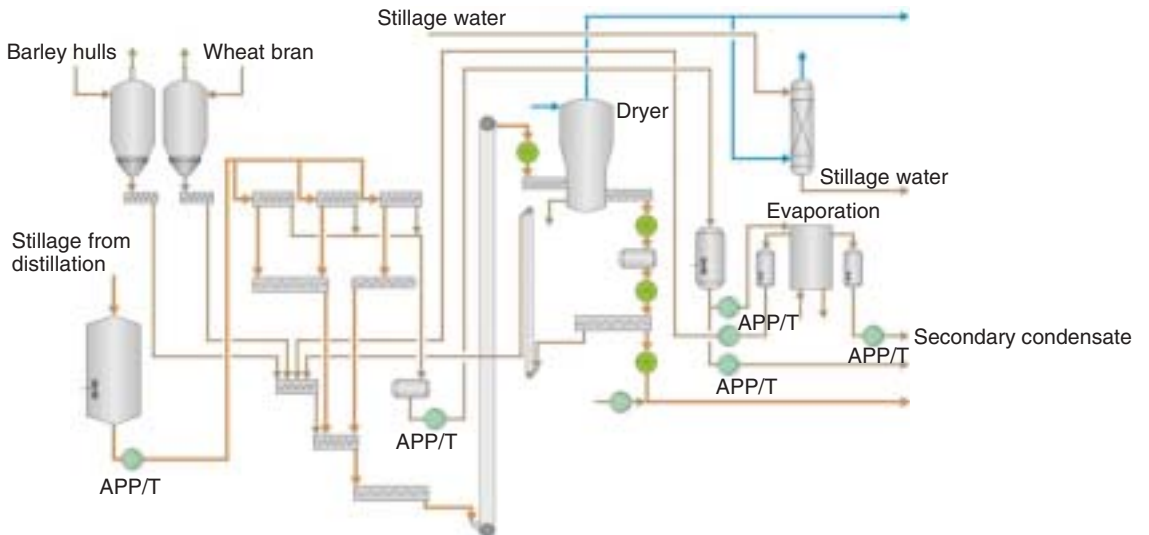



SULZER

Check our worldwide offices at
www.sulzerpumps.com