

**SULZER**

Corn Refiners Association, Inc.



## **Sulzer Pumps for Corn Starch Applications**

The  
Heart  
of Your  
Process





# Sulzer Pumps at Your Service

AHLSTAR™ APP/APT\* the standard process pumps are designed according to ISO 5199/ISO 2858 standards for all normal pumping applications for clean, abrasive or corrosive liquids and also for liquids containing fibers.



AHLSTAR™ NPP/NPT non-clogging pumps are designed according to ISO 5199/ISO 2858 standards for pumping liquids, slurries and stocks containing large solids and long fibers. The pumps are equipped with the Sulzer dynamic seal in most of the applications.



AHLSTAR™ ASP/AST self priming gas removal pumps enable efficient and trouble-free pumping of liquids containing gas up to 70% or when self priming pumps are needed.



ADVANTAGE CPT chemical process pumps series is designed according to ANSI/ASME B73.1 M standards for all normal pumping applications for clean, abrasive or corrosive liquids and also for liquids containing fibers.



AHLSTAR™ WPP/WPT wear resistant pumps are designed for applications where durability is essential, like pumping both abrasive and corrosive liquids and slurries containing particles.



SALOMIX™ LV agitator is the slow rotating top entry agitators with AF/AFX -paddles for efficient starch handling. The LV agitators are available for the most storage and production tank applications.



## PUMPS FOR OTHER UTILITIES

we also have wide range of pumps for applications in water transport, boiler feed and dewatering.

\* P and T versions refer to metric and inch measures



## Advanced Pumping Solutions for the Starch Industry

Sulzer Pumps has made hundreds of pumps that are running in demanding applications in starch and starch based sweetener industries. Our high quality products and deep understanding of starch processes generate reliable pumping solutions to meet the needs of our customers.

A problem frequently faced by the starch industry is pumping liquids that have a tendency to foam. This special feature of starch processes arises partly because of the protein content of the pumped liquids and partly because the different raw material components are separated mechanically.

The AHLSTAR™ ASP Self Priming Gas Removal Pump is the perfect solution to pump these foamy liquids, and at the same time remove significant amounts of the troublesome air to help with downstream processing. Other pumping solutions for the starch industry from Sulzer Pumps are the AHLSTAR™ APP Process Pumps and ADVANTAGE CPT Chemical Process Pumps. Both can be equipped with the unique Dynamic Seal for leak-free shaft sealing.

In the Dynamic Seal there are no narrow areas corresponding to the seal faces in mechanical seals, and no wearing parts. No sealing water and thus no sealing water systems are needed for the Dynamic Seal.

Until now, conventional mechanical seals and stuffing boxes have been the most maintenance intensive components of centrifugal pumps used in the starch industry. Thanks to the Dynamic Seal, mechanical wear, leakage and the need for sealing liquid have been practically eliminated.

Sulzer Pumps' AHLSTAR™ series is designed according to ISO 5199 standards. Our ADVANTAGE CPT Chemical Process Pumps series is designed according to ANSI/ASME B73.1 M standards. Both pump series are designed for continuous operation in process industries.

Let's make the best out of your process pumping!



Corn Refiners Association, Inc.

# Steeping of Maize (Corn)

**Special features: dynamic seals**

## For steeping waters

The AHLSTAR™ NPP/NPT and ADVANTAGE CPT pumps

- corrosion and wear resistant stainless ASTM A890-94a 3A and 1B
- Sulzer dynamic seals suitable for slurries, eliminating the need for costly mechanical seals
- vortex impellers (NPT) for slurries with large pieces or particles in steeped slurry



# Milling Operations

## First grind operations and germ separation

The AHLSTAR™ WPP/WPT wear and corrosion resistant materials for sticky (amylo maize) starches with

- dynamic seals eliminating the need for mechanical seals
- hydraulic design to prevent build up of corn slurry in pump and seal area

The AHLSTAR™ APP/APT and ADVANTAGE CPT pumps for No.2 dent or waxy corn slurries with

- dynamic seals eliminating the need for mechanical seals
- wear and corrosion resistant stainless steels
- over 60 sizes to meet flow and head requirements of the customer



### **Second grind operations and germ separation**

The AHLSTAR™ WPP/WPT wear and corrosion resistant materials for sticky (amylo maize) starches with

- dynamic seals eliminating the need for mechanical seals
- hydraulic design to prevent build up of corn slurry in pump and seal area

The AHLSTAR™ APP/APT and ADVANTAGE CPT pumps for No.2 dent or waxy corn slurries with

- dynamic seals eliminating the need for mechanical seals
- wear and corrosion resistant stainless steels
- over 60 sizes to meet flow and head requirements of the customer

### **Third grind operations and fiber washing**

The AHLSTAR™ ASP/AST and WSP/WST pumps for foaming liquids with

- degassing of entrained gases eliminating the need to oversize pumps and possibly eliminating the need for anti foam or defoaming agents

The AHLSTAR™ WPP/WPT wear and corrosion resistant materials for sticky (amylo maize) starches with

- dynamic seals eliminating the need for mechanical seals
- hydraulic design to prevent build up of corn slurry in pump and seal area

The AHLSTAR™ APP/APT and ADVANTAGE CPT pumps for No.2 dent or waxy corn slurries with

- dynamic seals eliminating the need for mechanical seals
- wear and corrosion resistant stainless steels
- over 60 sizes to meet flow and head requirements of the customer

### **Starch and gluten separation**

The AHLSTAR™ ASP/AST pumps for foaming liquids with

- degassing of entrained gases eliminating the need to oversize pumps and possible eliminating the need for anti foam or defoaming agents
- possibility of elimination of entrained gases that can help or stabilize the operation of centrifuges
- possibility of assisting the gluten filter efficiency through the elimination of gases

The AHLSTAR™ APP/APT and ADVANTAGE CPT pumps for No.2 dent or waxy corn slurries with

- dynamic seals eliminating the need for mechanical seals
- wear and corrosion resistant stainless steels
- over 60 sizes to meet flow and head requirements of the customer



# Germ Plant and Feed House Operations

## Corn oil extraction

The AHLSTAR™ APP/APT and ADVANTAGE CPT pumps with

- mechanical seal options for hazardous pumping operations
- wear and corrosion resistant stainless steels available for all applicaitons
- over 60 sizes to meet flow and head requirements of the customer

## High fructose corn syrup plant

The AHLSTAR™ APP/APT and ADVANTAGE CPT pumps with

- mechanical seal options for hazardous pumping operations
- wear and corrosion resistant stainless steels available for all applicaitons
- over 60 sizes to meet flow and head requirements of the customer

## Steep water evaporation and fiber, germ and gluten drying

The AHLSTAR™ APP/APT and ADVANTAGE CPT pumps with

- mechanical seal options for hazardous pumping operations
- wear and corrosion resistant stainless steels available for all applicaitons
- over 60 sizes to meet flow and head requirements of the customer





# Other Utilities

## Water transport

The B series of vertical line shaft pumps consist of BK, BS and BP ranges. They are primarily used in water lift, transfer and cooling water applications.

AHLSTAR™ NVP/NVT non-clogging vertical pumps are intended for all kinds of hard applications with waste water, slurries or waste stock.

SM/SMN single stage double entry pumps are used across a broad range of industries in liquid transport and transfer applications.

ZPP double suction pumps are designed for applications including cooling and circulating water pumping.

## Boiler feed

The HPP/HPT high pressure multistage pumps are used for pumping clean or slightly contaminated liquids in high pressure applications in various industries.

The M series of ring section multistage pumps consist of MB, MD and ME ranges. A wide range of common hydraulic components and bearing assemblies are used within the 4 standard pressure ranges.

## Dewatering

The HPH/HPL multistage pumps are specifically designed for dewatering applications. Their robust construction is designed to combat the highly abrasive environment in which they operate.



# Corn Starch Process

## Steeping

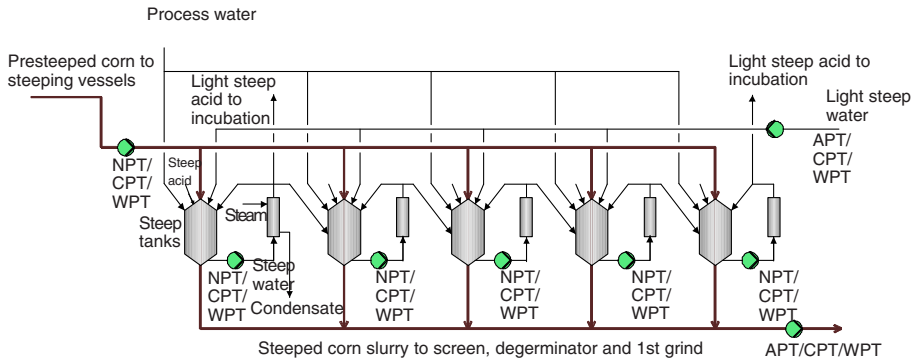

## Milling and Germ Separation

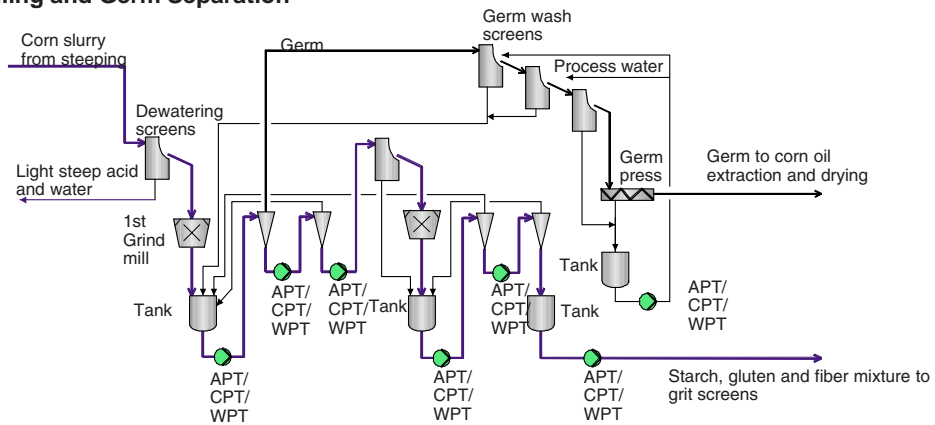

## Fiber Separation

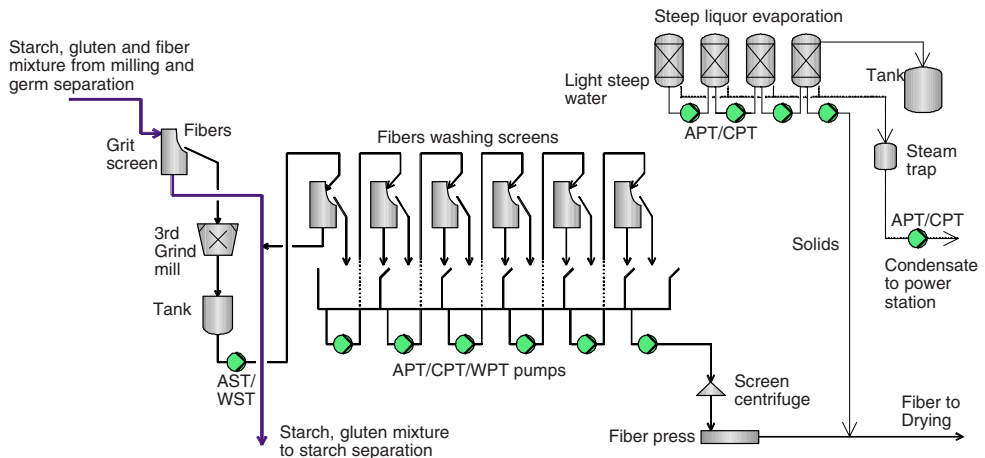

## Starch Separation and Washing

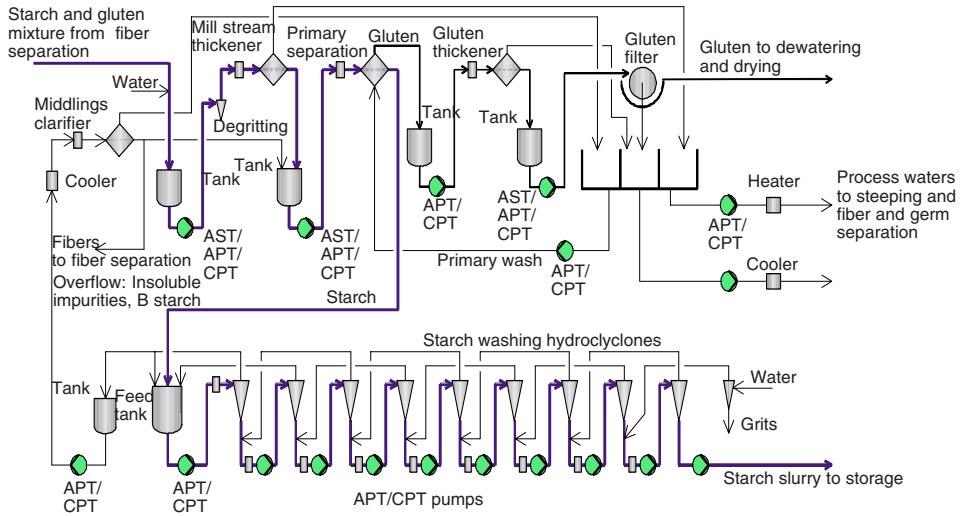

## Syrup Refining

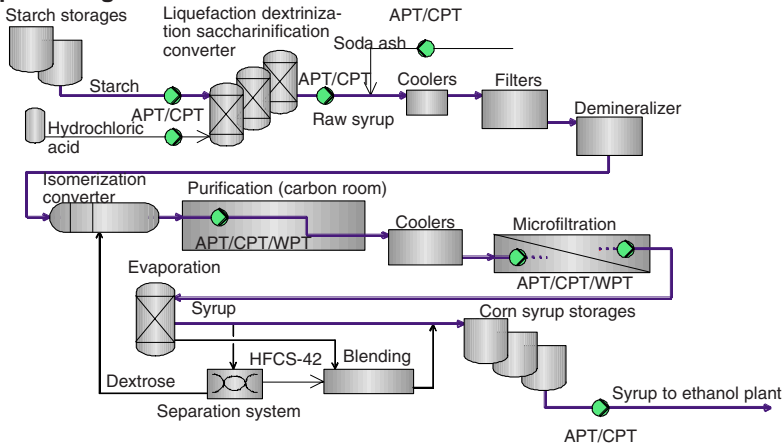

## Corn Oil Extraction

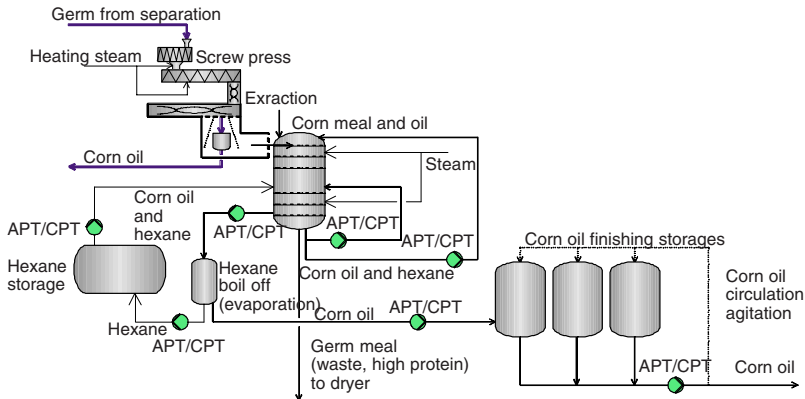

# SULZER

Corn Refiners Association, Inc.



Check our worldwide offices at  
[www.sulzerpumps.com](http://www.sulzerpumps.com)