

SULZER

Sulzer Pumps for Beet Sugar Applications

The **Heart**
of Your
Process





Sulzer Pumps at Your Service

AHLSTAR™ APP/APT* the standard process pumps for all the normal pumping applications.



AHLSTARô WPP/WPT wear resistant pumps are designed for applications where durability is essential, like pumping both abrasive and corrosive liquids and slurries containing particles.



AHLSTARô ASP/AST self priming gas removal pumps enable efficient and trouble-free pumping of liquids containing gas up to 70% or when self priming pumps are needed.



AHLSTARô NPP/NPT non-clogging pumps for the continuous pumping of liquids, slurries and stock containing large solids and long fibers.



SALOMIXô LV Agitators slow rotating vertical agitators with AF/AFX -paddles for efficient sludge handling in purification of beets and mixing defoamer tank contents during extraction.



HPP/HPT high pressure multistage process pumps for pumping of clean or slightly contaminated liquids in high pressure applications.



AHLSTARô WSP/WST wear resistant self priming gas removal pumps enable trouble-free pumping of corrosive and abrasive liquids containing gas up to 70% or when self priming pumps are needed.



Vertical agitators with sixblade special SALOMIXô propeller for crystallization pans. These agitators are always tailored to the pan.



PUMPS FOR OTHER UTILITIES
we also have wide range of pumps for applications in water transport, boiler feed and dewatering.

* P and T versions refer to metric and inch measures



Advanced Pumping Solutions for the Sugar Industries

Sulzer Pumps has hundreds of pumps running in demanding applications in the sugar industry. Our high quality products and deep understanding of sugar processes generate reliable pumping solutions to meet the needs of our customers.

One crucial factor in the sugar industry is reliable sealing. In the Dynamic Seal there are no narrow areas corresponding to the sealing face area in mechanical seals where sugar can crystallize and cause sealing damage.

Furthermore, there are no wearing parts, nor sealing water system requirements. That's why Sulzer Pumps' Dynamic Seal is needed in every sugar pumping application, whenever possible!

Sulzer Pumps' AHLSTAR® series is designed according to ISO 5199 standards for continuous operation in industrial processes. One key features of this product line is the interchangeability of parts and components. This allows new technology to be easily incorporated into the full range of product offerings.

Material selection has a major effect on pump lifetime. The general drive to increase efficiency throughout the sugar process, including the use of one-pump systems, makes the selection of every pump and its material more important than ever before.

Let's make the best out of your sugar pumping!



Washing

Special features: sand, oil and beet tails

For waters containing solid beet tails

- The AHLSTAR® WPP/WPT wear resistant process pumps with
- vortex impeller
 - ASTM A532 IIIA corrosion and wear resistant material
 - a unique dynamic shaft seal
- Or
- The AHLSTAR® NPP/NPT non-clogging process pumps
- vortex impeller
 - corrosion and wear resistant stainless steel A747 CB7Cu-2
 - unique dynamic shaft seal

For dirty sump waters containing solid particles

- The AHLSTAR® WSP/WST wear resistant self priming gas removal pumps with
- vortex impeller
 - ASTM A532 IIIA corrosion and wear resistant chromium iron material
 - internal vacuum system

For washing waters containing sand and mud

- The AHLSTAR® WPP/WPT wear resistant process pumps with
- open impeller
 - ASTM A532 IIIA corrosion and wear resistant chromium iron material
 - unique dynamic shaft seal

Extraction

Special features: foam and sand

For juices and waters

- The AHLSTAR® APP/APT process pumps with
- closed impeller
 - ASTM A890 3A corrosion and wear resistant duplex stainless steel material
 - unique dynamic shaft seal

For juices containing gases and cossettes

- The AHLSTAR® NPP/NPT non-clogging process pumps with
- non-clogging impeller
 - ASTM A890 3A corrosion and wear resistant stainless steel material
 - unique dynamic shaft seal

For defoamer tank

- The SALOMIX® LV Agitator with
- gear drive
 - high efficiency AF/AFX paddles
 - material SS2343 of parts in contact with liquid



Purification

Special features: alkalinity, low speed pumping

For the milk of lime

The AHLSTAR® WPP/WPT wear resistant process pumps with

- closed impeller
- ASTM A532 IIIA corrosion and wear resistant chromium iron material
- unique dynamic shaft seal

For limed juices and lime slurries before the 1st filtration

The AHLSTAR® WPP/WPT wear and corrosion resistant process pumps with

- open impeller
- ASTM A890 3A corrosion and wear resistant duplex stainless steel material
- unique dynamic shaft steel

For filtrates, washing waters and juices after the 1st filtration

The AHLSTAR® APP/APT process pumps with

- open impeller
- ASTM A890 3A corrosion and wear resistant duplex stainless steel material or A48 CL 30 B cast iron material
- unique dynamic shaft seal

For sludge tank

The SALOMIX® LV agitator with

- gear drive
- high efficient SALOMIX® paddles (AF/AFX type)
- material SS2343 of parts in contact with liquid

For high pressure waters

The HPP/HPT high-pressure multi-stage pumps with

- closed impellers
- ASTM A890 3A corrosion and wear resistant duplex stainless steel material
- unique dynamic shaft seal

For collected floor juices

The AHLSTAR® ASP/AST self priming gas removal process pumps with

- open impeller
- ASTM A890 3A corrosion and wear resistant duplex stainless steel material
- internal vacuum system





Beet sugar mill in Spain

Evaporation

Special features: low NPSH values, high temperatures

For juices and primary condensates

- The AHLSTAR[®] APP/APT process pumps with
- high efficiency, low-NPSHr closed impeller
 - ASTM A890 3A corrosion and wear resistant duplex stainless steel material
 - unique dynamic shaft seal or ready fitted mechanical seal

For secondary condensates

- The AHLSTAR[®] APP/APT process pumps with
- high efficiency, low-NPSHr closed impeller
 - A48 CL 30 B cast iron (temperature limit 120 °C) or ASTM A890 3A corrosion and wear resistant duplex stainless steel material
 - unique dynamic shaft seal or ready fitted mechanical seal



Crystallization

Special features: gas and viscosity

For juices, waters and chemicals

- The AHLSTAR[™] APP/APT process pumps with
- open impeller
 - ASTM A890 3A corrosion and wear resistant duplex stainless steel material
 - unique dynamic shaft seal

For run-offs and molasses

- The AHLSTAR[®] ASP/AST self priming gas removal process pumps with
- open impeller
 - ASTM A890 3A corrosion and wear resistant duplex stainless steel material
 - internal vacuum system

For A-, B- and C- pans

- The SALOMIX[®] LV -agitator with
- versatile gear drive
 - special high axial flow propeller
 - SS2343 material for parts in contact with liquid
 - different seal options



Lime Kiln

Special features: alkalinity and abrasion by milk of lime

For lime milk recirculation

The AHLSTAR[®] WPP/WPT wear resistant process pumps with

- open impeller
- ASTM A532 IIIA corrosion and wear resistant chromium material
- unique dynamic shaft seal

For lime milk to purification

The AHLSTAR[®] WPP/WPT wear resistant process pumps with

- open impeller
- ASTM A532 IIIA corrosion and wear resistant chromium iron material
- unique dynamic shaft seal

For sump waters

The AHLSTAR[®] WSP/WST wear resistant self priming gas removal process pumps with

- vortex impeller
- ASTM A532 IIIA corrosion and wear resistant chromium iron material
- internal vacuum system

Other Utilities

Water transport

The B series of vertical line shaft pumps consist of BK, BS and BP ranges. They are primarily used in water lift, transfer and cooling water applications.

AHLSTAR[™] NVP/NVT non-clogging vertical pumps are intended for all kinds of hard applications with waste water, slurries or waste stock.

SM/SMN single stage double entry pumps are used across a broad range of industries in liquid transport and transfer applications.

ZPP double suction pumps are designed for applications including cooling and circulating water pumping.

Boiler feed

The HPP/HPT high pressure multi-stage pumps are used for pumping clean or slightly contaminated liquids in high pressure applications in various industries.

The M series of ring section multi-stage pumps consist of MB, MD and ME ranges. A wide range of common hydraulic components and bearing assemblies are used within the 4 standard pressure ranges.

Dewatering

The HPH/HPL multistage pumps are specifically designed for dewatering applications. Their robust construction is designed to combat the highly abrasive environment in which they operate.

Beet Sugar Evaporation

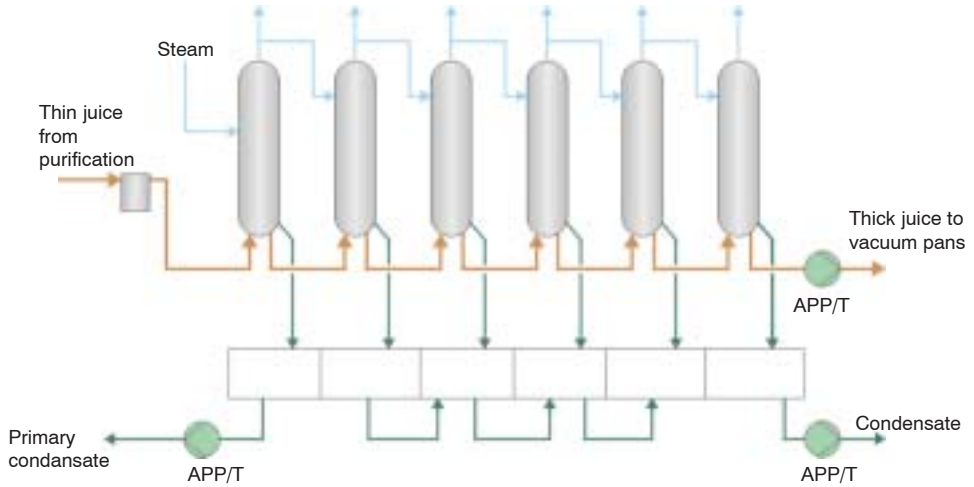

Beet Sugar Crystallization

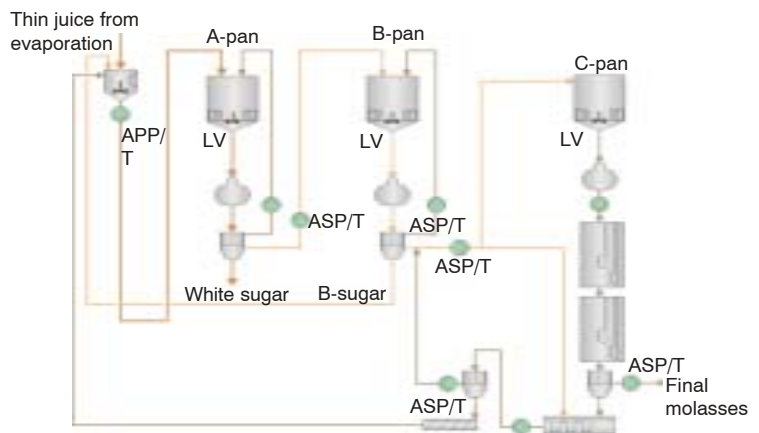

Beet Sugar Lime Burning

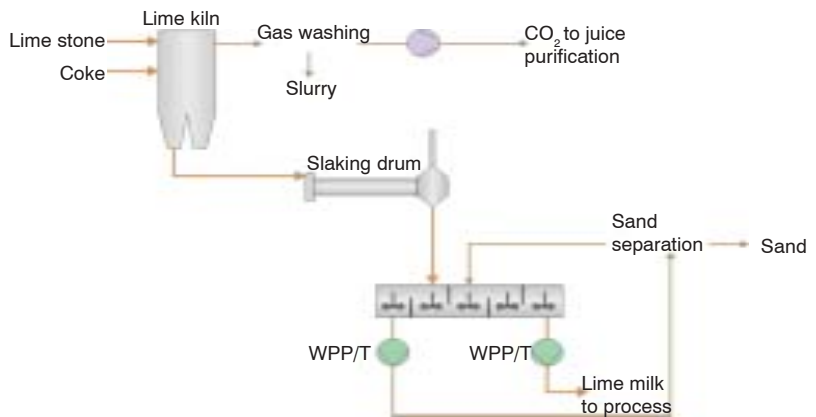



Check our worldwide offices at
www.sulzerpumps.com