



## Service Kits for AHLSTAR™ Process Pumps

Each time a pump is serviced it is necessary to replace the o-rings, gaskets and other small parts. Depending on which area of the pump is being serviced, different such items will be required. To make the work of servicing easier and faster, these parts should be on hand and easily identifiable.

Service Kits for AHLSTAR™ process pumps have been developed to simplify specific service tasks, such as changing the impeller, servicing a bearing unit, changing a sideplate or

servicing a dynamic seal. All the o-rings and gaskets etc. required for a specific service task on one pump are in one package, clearly marked with the pump size and the specific service task including its own unique identification number. Purchasing is simplified as that one number replaces a list of numbers and descriptions for items in the kit. AHLSTAR™ Process Pumps are of modular design, which means that one Service Kit can serve many pump types and sizes, thus reducing spare part inventories and saving costs.

Sturdy packaging and clear marking make the Service Kits easy to store and easy to use. The packaging protects the individual items from damage and can be recycled after use.

New, genuine spare parts, including gaskets and o-rings, should always be used when servicing a pump. This ensures the reliability, and reduces the lifetime costs of the serviced pump.

Please contact your local sales office for further information.

### Benefits for the customer

- Pump service based kits including all the necessary parts in one package
- Easy to specify and order
- Easy to store
- Usage of new genuine parts ensures the reliability of the pump



# Service Kits for AHLSTAR™ Process Pumps

## Sideplate Service Kit

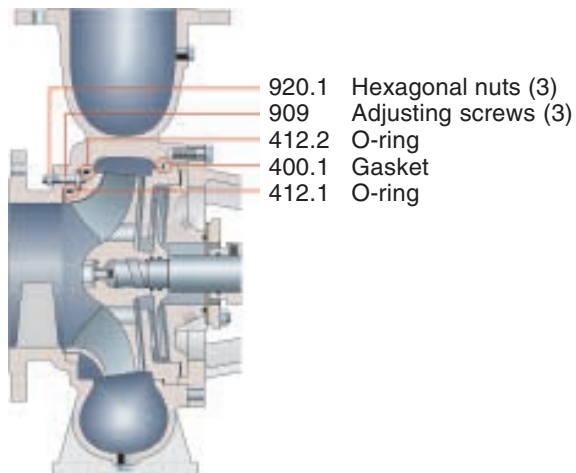

## Impeller Service Kit

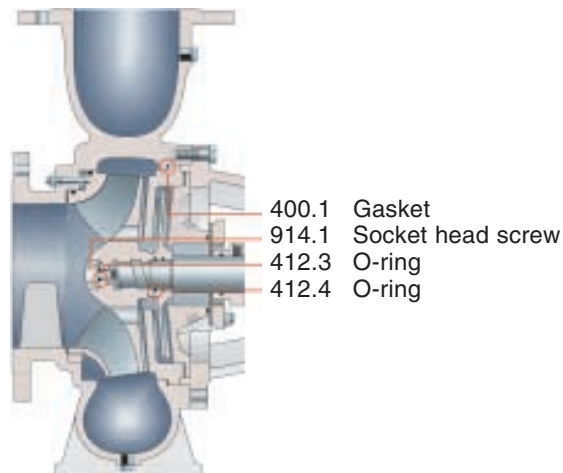

## Bearing Unit Service Kit

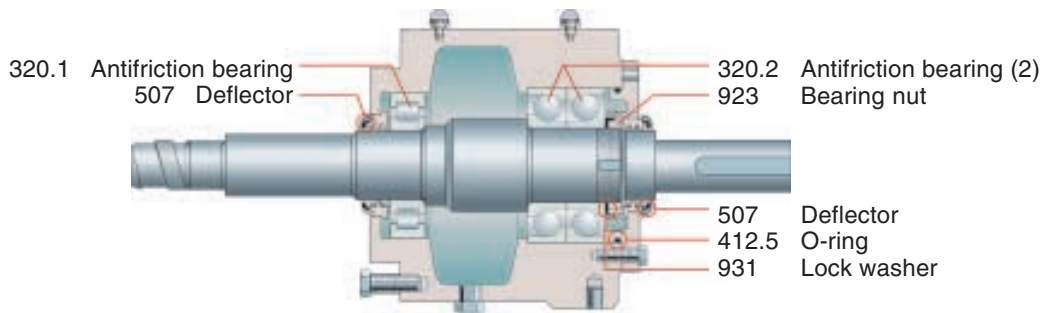

## Dynamic Seal Service Kit

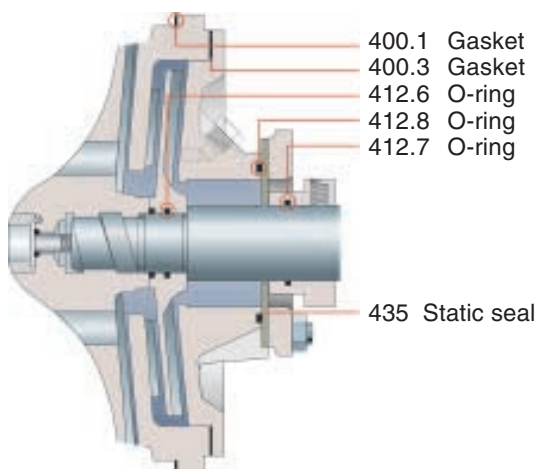

Check our worldwide offices at  
[www.sulzerprocesspumps.com](http://www.sulzerprocesspumps.com)