



## Service Kits for ZPP Double Suction Pumps

Each time a pump is serviced it is necessary to replace o-rings, washers, sleeves and other small parts. Distinct sets of parts are required for different service tasks. To make the work of servicing easier and faster, these parts should be readily available and easily identifiable.

Service kits for ZPP double suction pumps have been developed to simplify specific service tasks, such as servicing a bearing unit or changing gland packing. All the o-rings and screws etc. required for a

specific service task on one pump are in one package, clearly marked with its own unique identification number, the pump size and the specific service task. Purchasing is simplified as a single number replaces a list of numbers and descriptions for items in the kit.

Sturdy packaging and clear marking make the service kits easy to store and easy to use. The packaging protects the individual items from damage and can be recycled after use.

New, genuine spare parts should always be used when servicing a pump. This ensures the reliability, and reduces the lifetime costs of the serviced pump.

Please contact your local sales office for further information.

### Key Benefits

- Pump service based kits including all the necessary parts in one package
- Easy to identify and use
- Easy to specify and order
- Easy to store
- Saves time and costs in Maintenance and Purchasing
- Recyclable packaging
- Original spare parts ensure compatibility and reliability and reduce lifetime costs



## Gland Packing Service Kit

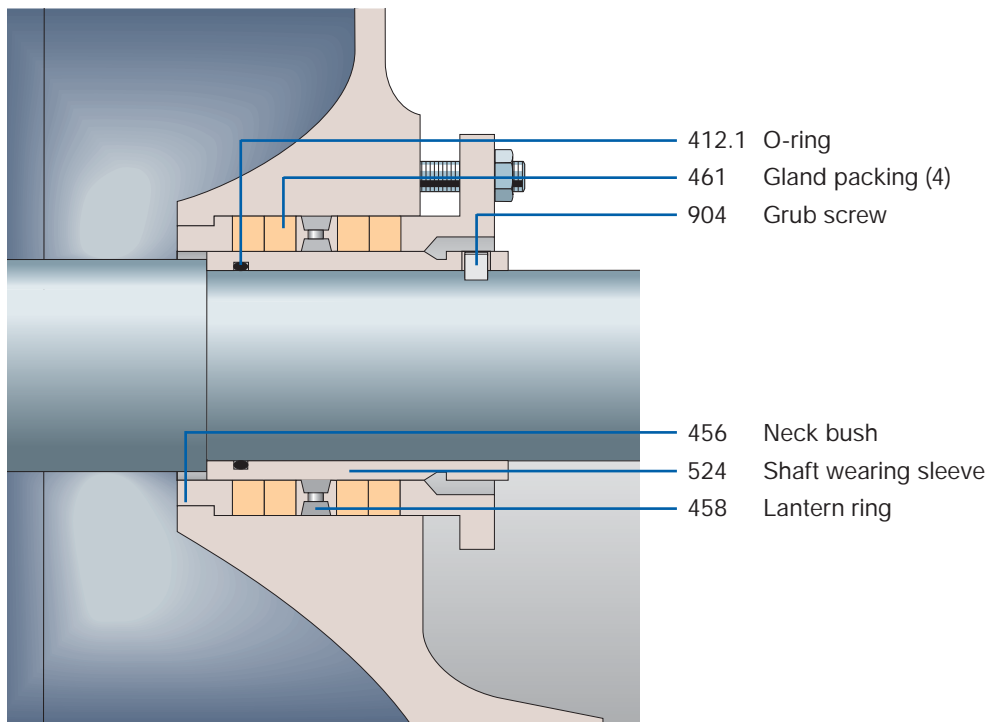

## Bearing Unit Service Kit

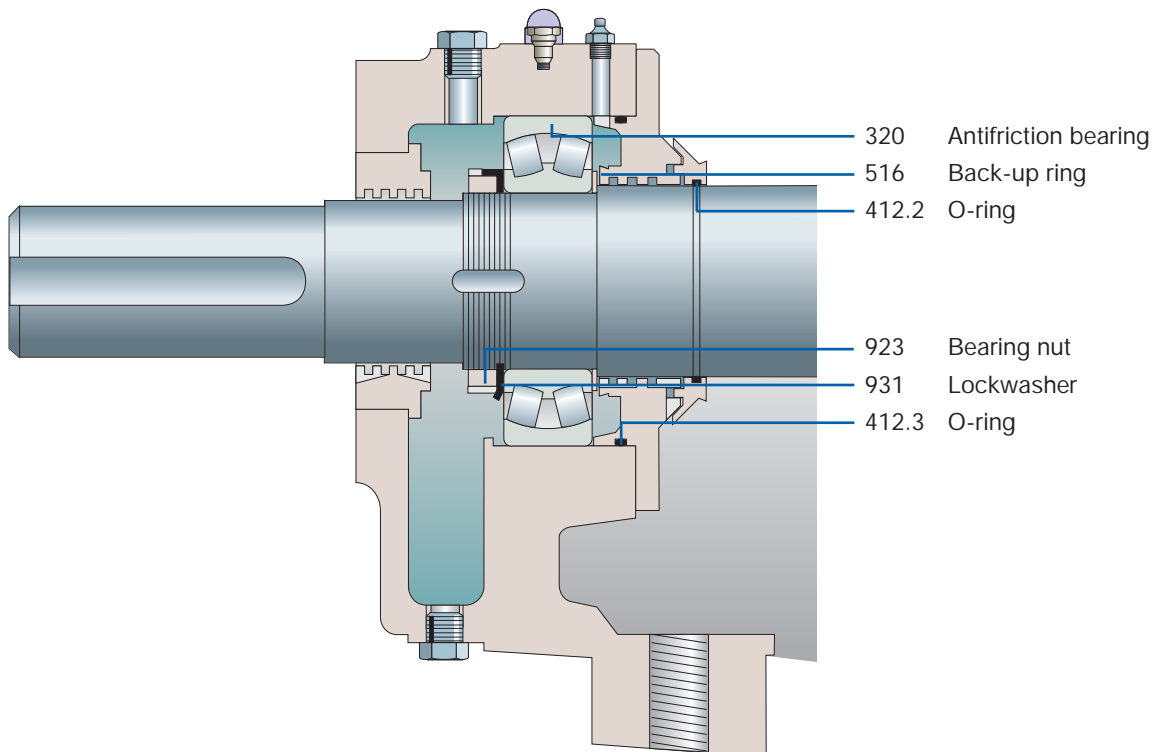

[www.sulzerpumps.com](http://www.sulzerpumps.com)  
[spareparts.spfin@sulzer.com](mailto:spareparts.spfin@sulzer.com)

E10042 en 12.2009, Copyright © Sulzer Pumps

This brochure is a general presentation. It does not provide any warranty or guarantee of any kind. Please, contact us for a description of the warranties and guarantees offered with our products. Directions for use and safety will be given separately. All information herein is subject to change without notice.