



SULZER

Sulzer Pumps

Service Kits for Sulzer Pumps and Agitators

The Heart of Your Process

Service Kits for Sulzer Pumps and Agitators

Each time a pump or agitator is serviced it is necessary to replace o-rings, gaskets, sleeves, bearings and other small parts. Distinct sets of parts are required for different service tasks. To make the work of servicing easier and faster, these parts should be readily available and easily identifiable.

Sulzer has developed service kits for pumps and agitators to simplify specific service tasks, such as changing the impeller, servicing a bearing unit, changing a sideplate, servicing a seal etc. All the o-rings, gaskets and other small parts required for a specific service task on one pump or agitator are in one package, clearly marked with its own unique identification number, the product type, size and the specific service task. Purchasing is simplified as a single number replaces a list of numbers and descriptions for items in the kit.

Sturdy packaging and clear marking make the service kits easy to store and easy to use. The packaging protects the individual items from damage and can be recycled after use.

New, genuine spare parts, including gaskets and o-rings, should always be used when servicing a pump or an agitator. This ensures the reliability, and reduces the lifetime costs of the serviced equipment.

Please find all available service kits for Sulzer pumps and agitators in this brochure. Contact your local sales office for further information.

Key Benefits for the Customer

- Pump service based kits including all the necessary parts in one package
- Easy to identify and use
- Easy to specify and order
- Easy to store
- Saves time and costs in Maintenance and Purchasing
- Reduced inventories and costs
- Recyclable packaging
- Original spare parts ensure compatibility and reliability and reduce lifetime costs

Sulzer Pumps Network of Locations

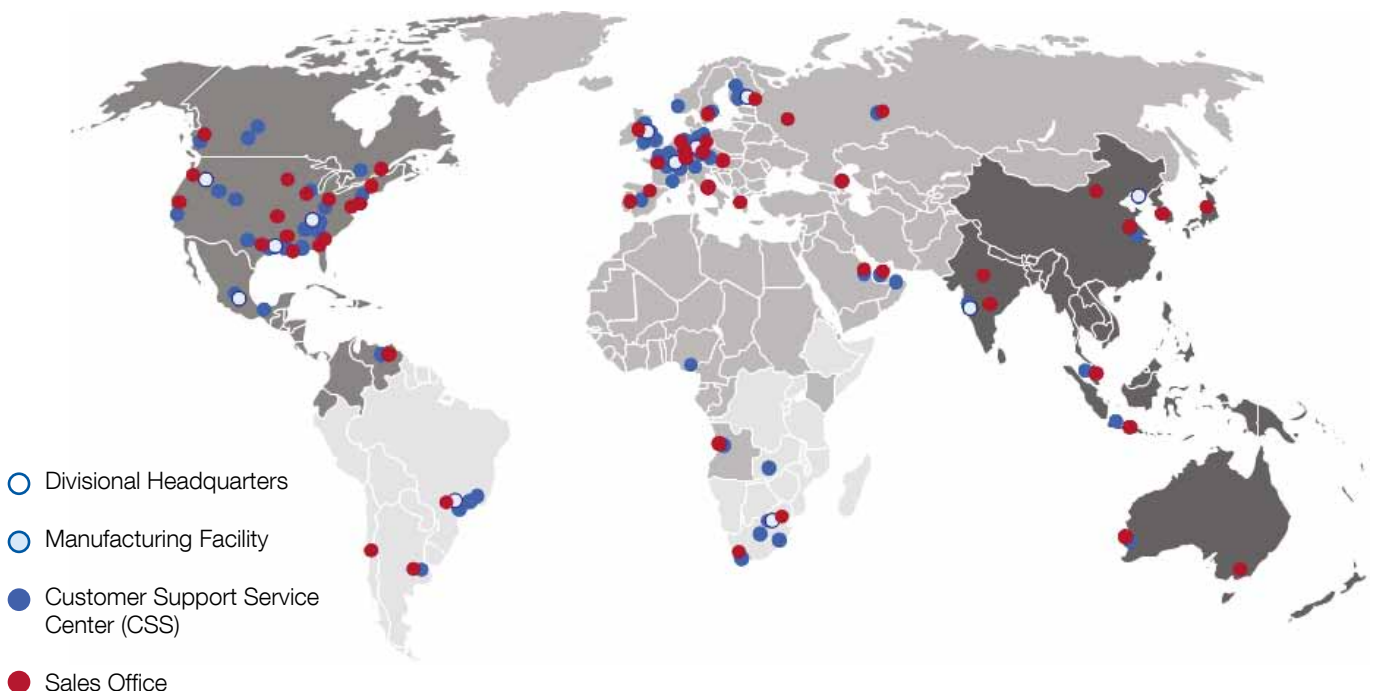

Service Kits for AHLSTAR^{UP} Process Pumps

Sideplate Service Kit

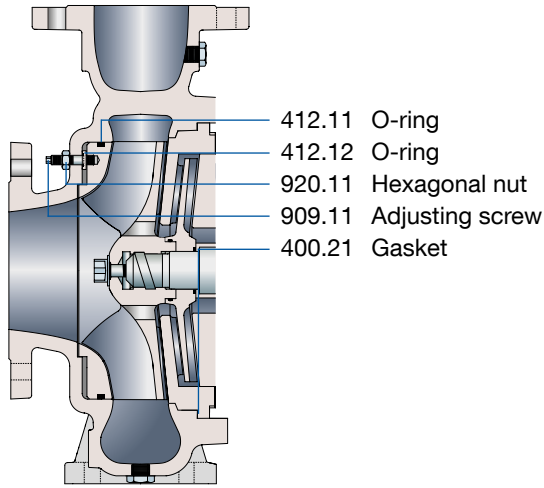

Impeller Service Kit

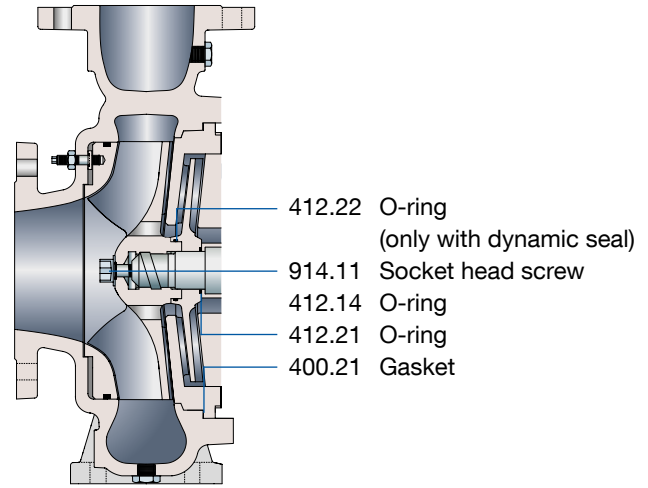

Dynamic Seal Service Kit

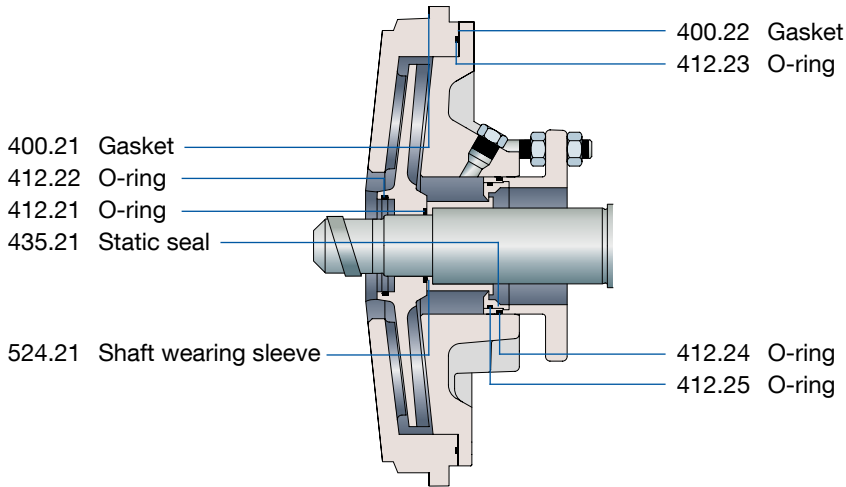

Bearing Unit Service Kit

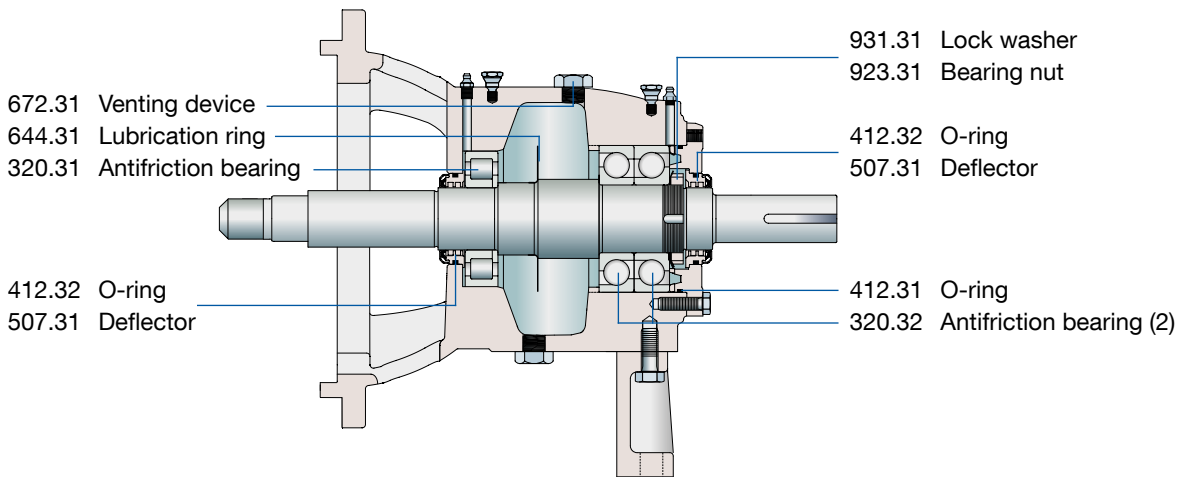

Service Kits for AHLSTAR™ Process Pumps

Sideplate Service Kit

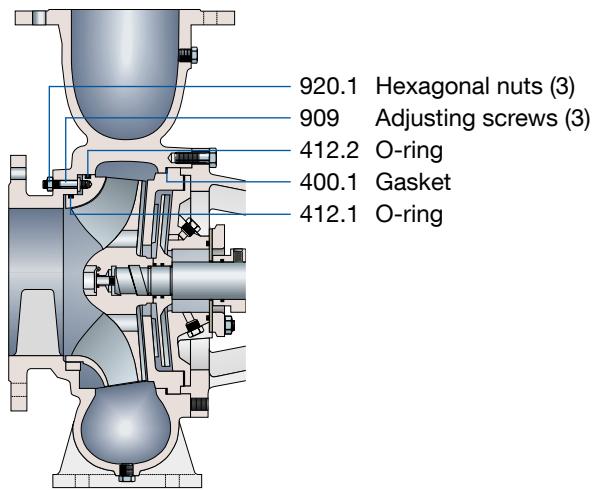

Impeller Service Kit

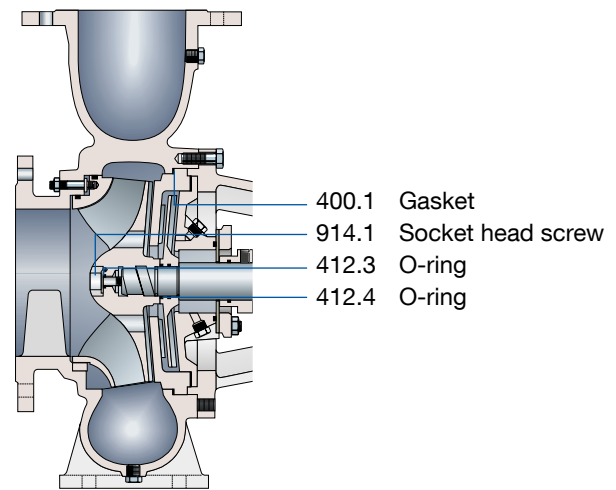

Dynamic Seal Service Kit

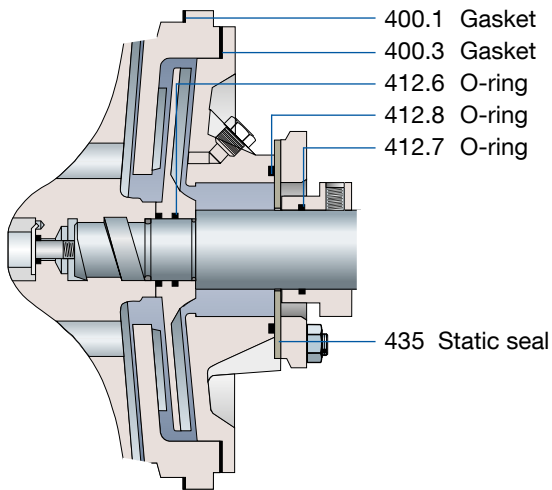

Gland Packing Service Kit

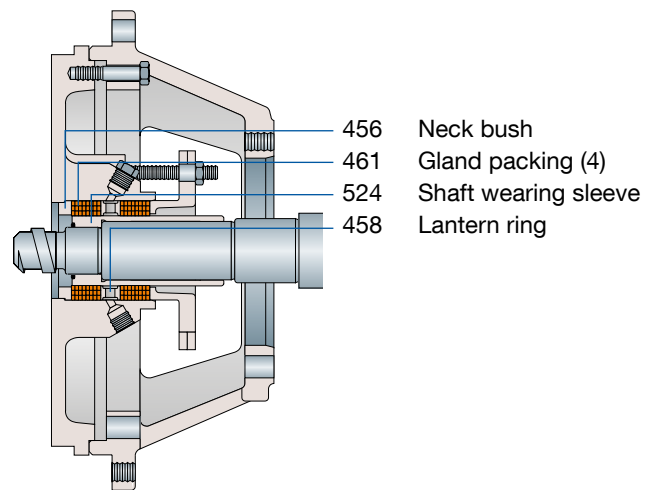

Bearing Unit Service Kit

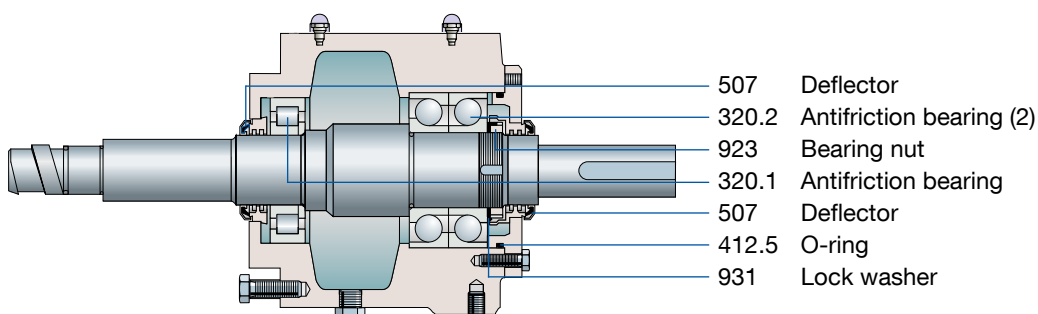

Service Kits for ZPP Double Suction Pumps

Gland Packing Service Kit

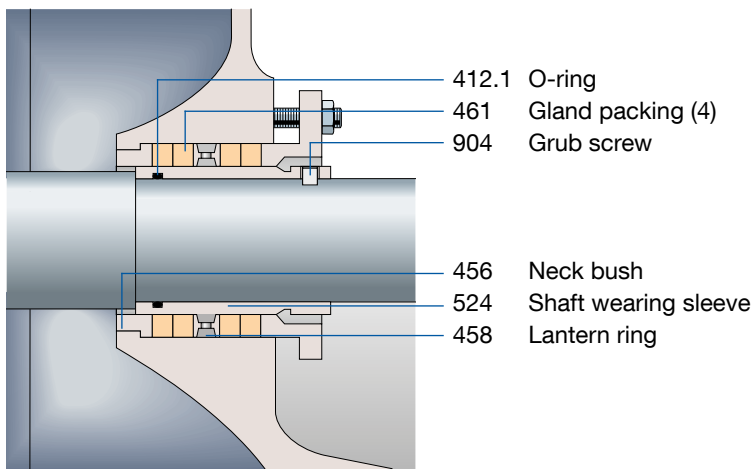

Bearing Unit Service Kit

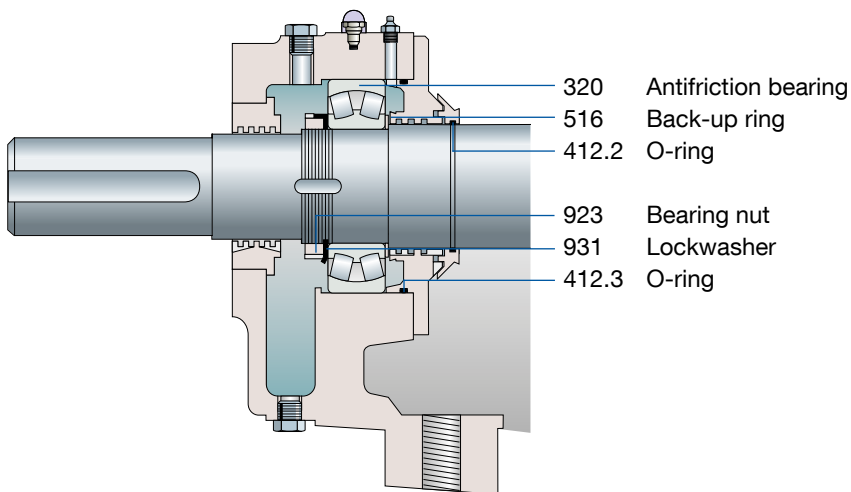

Service Kits for HPP Multistage Pumps

Balancing Drum Service Kit for HPP Pumps

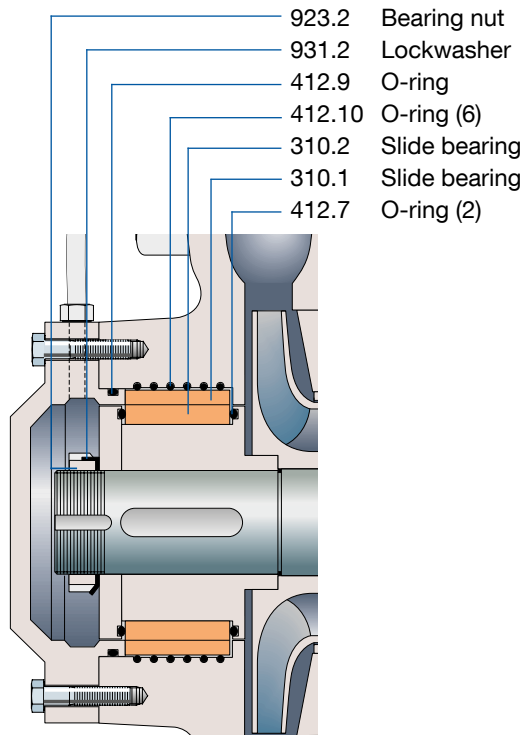

Bearing Unit Service Kit for HPP Pumps

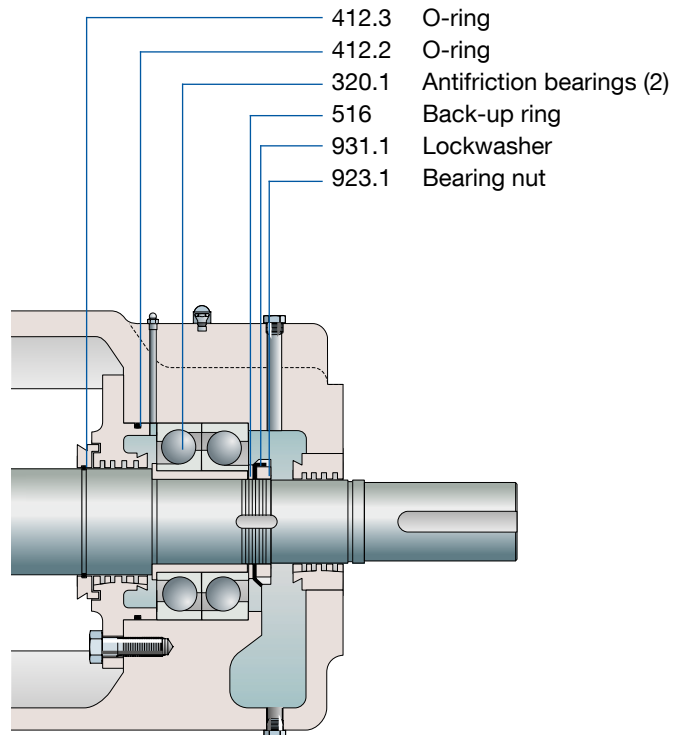

Service Kits for MBN Multistage Pumps

Balancing Drum Service Kit for MBN Pumps

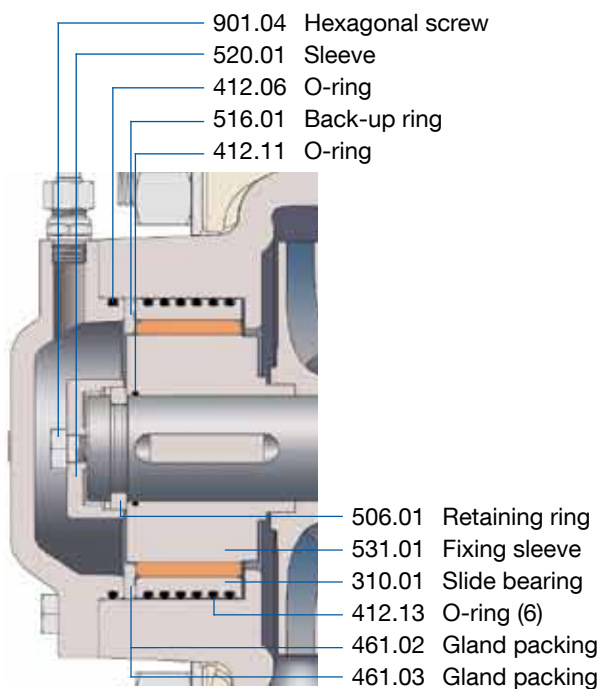

Bearing Unit Service Kit for MBN Pumps

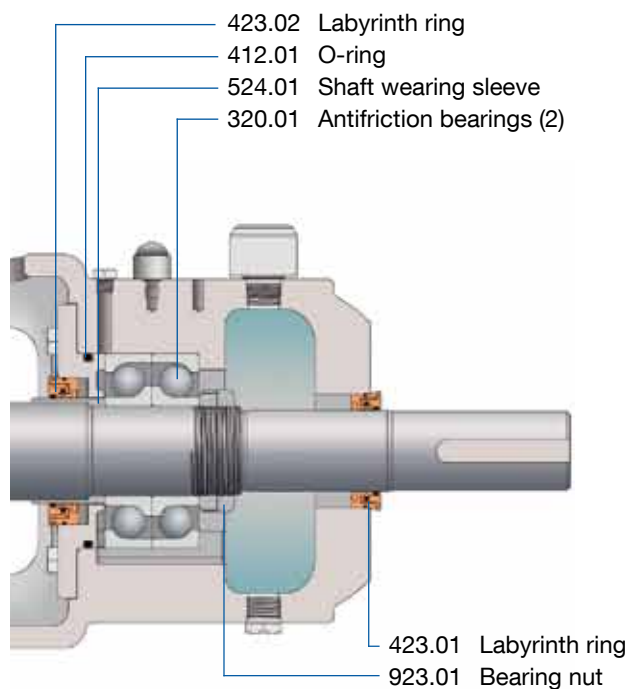

Service Kits for SL Agitators

Shaft Seal Service Kit for SLG/SLB Agitators with Double Mechanical Seal

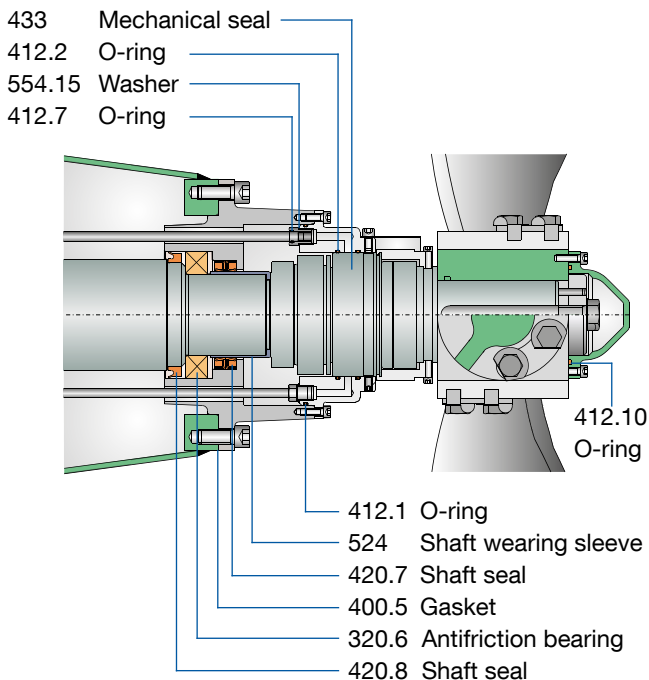

Shaft Seal Service Kit for SLG/SLB Agitators with Double Mechanical Seal with Labyrinth and Flushing

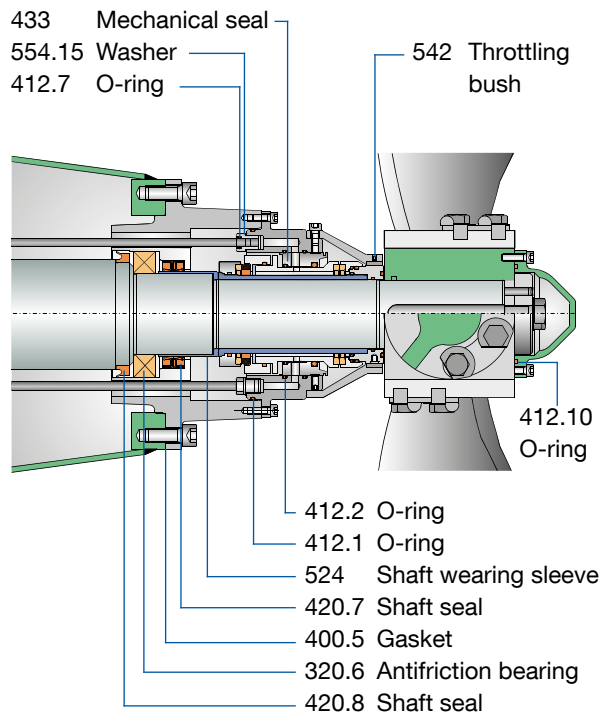

Shaft Seal Service Kit for SLG/SLB Agitators with Single Mechanical Seal with Labyrinth and Flushing

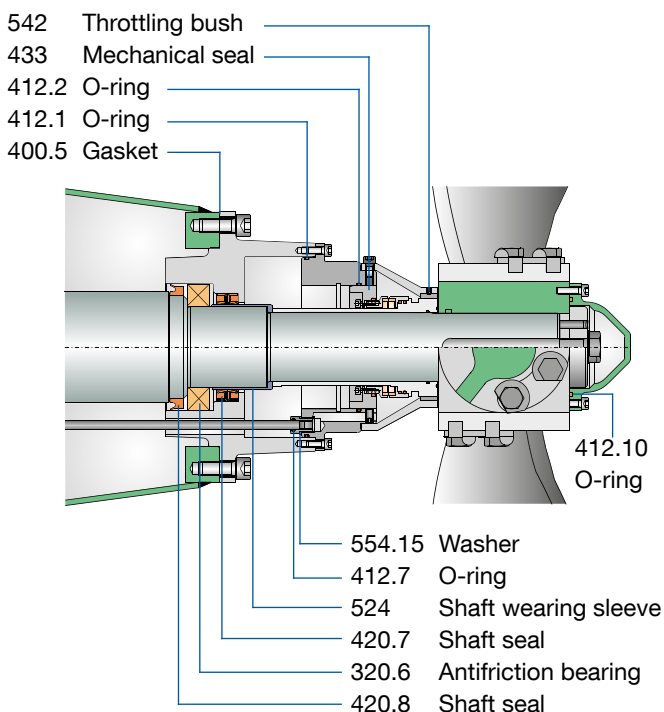

Shaft Seal Service Kit for SLF Agitators with Double Mechanical Seal

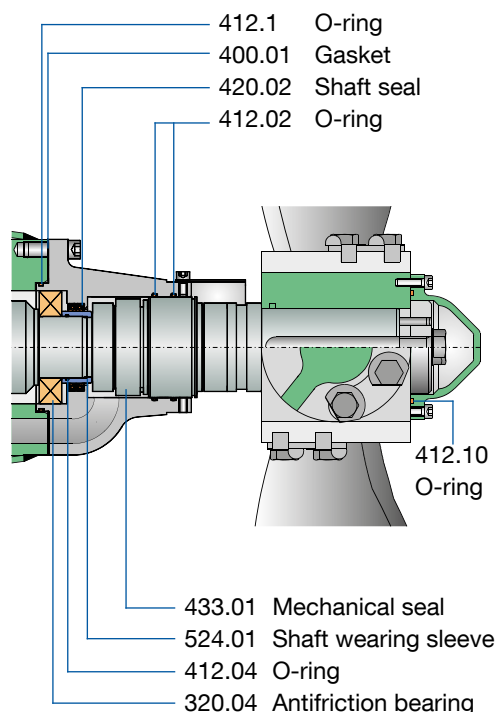



www.sulzerpumps.com
spareparts.spfin@sulzer.com